

Ficha técnica :

AGRICULTURAL MULTIFUNCTION GRAB BUCKET - FO



Customer benefits

- Rugged, multi-purpose attachment.
- Easy handling of compact manure.
- Total jaw opening allows working flush with walls.
- Versatile attachment that enables occasional square bale handling.
- Very good visibility, faster work.

Technical characteristics

- Forged teeth -FO.
- Handling materials with a density $\leq 1000 \text{ kg/m}^3$ / 62 lb/ft³.
- Dismountable sides, spill guard and 500 HB bolt-on cutting edge standard.
- Reinforced structure (base, blade and grab).
- Nitritized cylinders, all pins with "construction type" mounting.

[The 3D picture at the top of this page is the reference BG 2450 / 1700 FO - 52549810].

Technical characteristics		BG 1500 / 850 FO	BG 1850 / 1050 FO	BG 2100 / 1200 FO	BG 2300 / 1350 FO	BG 2450 / 1400 FO	BG 2450 / 1700 FO
Distance to center of gravity (mm)		421	435	396	408	407	-
Capacities							
Capacity (kg)		850	1059	1200	1335	1426	1695
Heaped capacity (l)		850	1059	1200	1335	1426	1695
Struck capacity (l)		521	650	740	813	868	1150
Weight							
Overall weight (kg)		560	636	720	763	803	870
Weight and dimensions							
Overall length (mm)	l1	1238	1263	1256	1256	1256	1367
Width (mm)		1500	1850	2100	2300	2450	2450
Closed grab height (mm)	h33	1039	1033	1033	1031	1033	1124
Opened grab height (mm)	h34	1675	1675	1675	1675	1675	1886
Working Parameters							
Machine Equipment							
Teeth		6	7	8	9	10	11
Fork spread minimum (mm)	b5	265	265	263	255	242	219
Fork spread maximum (mm)	b5	266	265	263	255	244	219
Other Data for Attachments							
Bolted wearplate (LDR)		Standard	Standard	Standard	Standard	Standard	Standard
Wear plate hardness		500	500	500	500	500	500

Compatibilidad de la máquina	BG 1500 / 850 FO	BG 1850 / 1050 FO	BG 2100 / 1200 FO	BG 2300 / 1350 FO	BG 2450 / 1400 FO	BG 2450 / 1700 FO
Reference number	52651958	52647327	52647329	52647331	52647333	52549810
Skid Steer Carga reference	52651957	-	-	-	-	-
ALT950	-	-	-	X	X	X
MLA-T 533-145 V+ - ST5	-	-	-	X	X	X
MLT 420-60 H	X	-	-	-	-	-
MLT 625-75 H	-	X	-	-	-	-
MLT 630-115	-	-	X	X	X	X
MLT 630-115 V	-	-	X	X	X	X
MLT 630-115 V CP	-	-	X	X	X	X
MLT 635-130 PS+	-	-	-	-	X	X
MLT 635-140 V+	-	-	-	-	X	X
MLT 730-115 V	-	-	X	X	X	X
MLT 730-115 V CP	-	-	X	X	X	X
MLT 733-115 LSU	-	-	-	-	X	X
MLT 737-130 PS+	-	-	-	-	X	X
MLT 741-130 PS+	-	-	-	-	X	X
MLT 741-140 V+	-	-	-	-	X	X
MLT 841-145 PS+	-	-	-	-	X	X
MLT 850-145 V+	-	-	-	-	-	X
MLT 940-140 V+	-	-	-	-	X	X
MLT 1041-145 PS+L	-	-	-	-	X	X
MLFX 625-75 H	-	X	-	-	-	-
MLFX 732	-	-	-	-	X	-
MLFX 735 T LSU	-	-	-	-	X	X
MLFX 737-130 PS+	-	-	-	-	X	X
MLFX 741 T LSU	-	-	-	-	X	X
MLFX 841 - 145 PS+	-	-	-	-	X	X
MLFX 850-145 V+	-	-	-	-	-	X
MLFX 1041-145 PS+L	-	-	-	-	X	X
MLT 630-105 ST4 OLD	-	-	X	X	X	X
MLT 630-105 V CP ST4 OLD	-	-	X	X	X	X
MLT 630-105 V ST4 OLD	-	-	X	X	X	X
MLT 635-130 PS+ ST4 OLD	-	-	-	-	X	X
MLT 635-140 V+ ST4 OLD	-	-	-	-	X	X
MLT 730-115 V CP ST4 OLD	-	-	X	X	X	X
MLT 730-115 V ST4 OLD	-	-	X	X	X	X
MLT 733-115 OLD	-	-	-	-	X	X
MLT 733-115 LSU ST4 OLD	-	-	-	-	X	X
MLT 733-115 ST4 OLD	-	-	-	-	X	X
MLT 737-130 PS+ ST4 OLD	-	-	-	-	X	X
MLT 741-140 V+ ST4 OLD	-	-	-	-	X	X
MLT 840-145 PS+ OLD	-	-	-	-	X	X
MLT 845-100 H OLD	-	-	-	-	X	X
MLT 845-120 OLD	-	-	-	-	X	X
MLT 940-140 V+ ST4 OLD	-	-	-	-	X	X
MLT 1040-145 PS+ L OLD	-	-	-	-	X	X
MLFX 737-130 PS+ OLD	-	-	-	-	X	X
MLFX 741-140 V+ S1 OLD	-	-	-	-	X	X
MLFX 840-140 PS+ OLD	-	-	-	-	X	X
MLFX 1040-140 PS+ L OLD	-	-	-	-	X	X

TABLA DE SÍMBOLOS					
	No se requiere predisposición		Línea hidráulica		Retorno al depósito de aceite hidráulico



Predisposición eléctrica



Predisposición de la plataforma



Predisposición manipulador de neumáticos, de cilindros

Agricultural Multifunction Grab Bucket - F0 - Diagrama dimensional

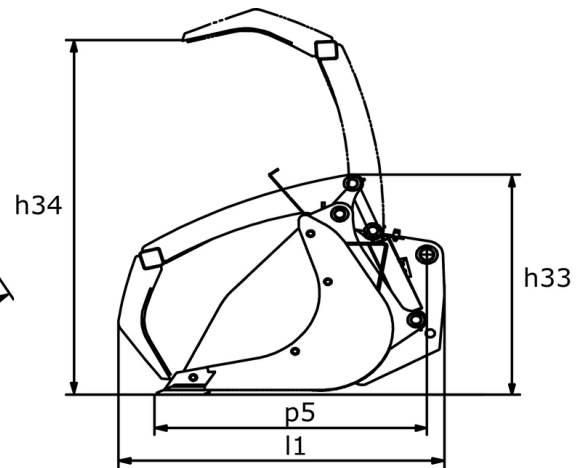
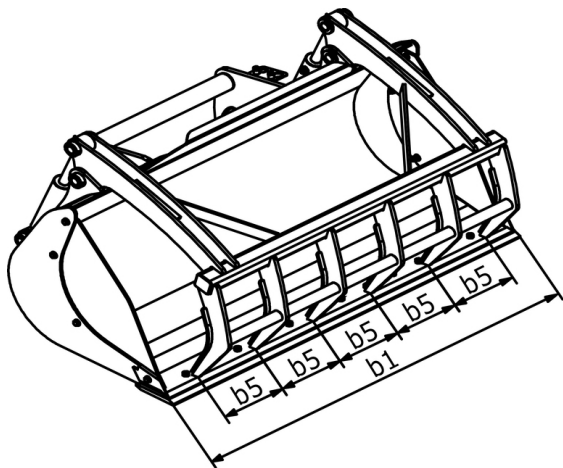



Oficina Central

B.P. 249 - 430 rue de l'Aubinière

44150 Ancenis Cedex - Francia

Tel.: 00 33 (0)2 40 09 10 11 - Fax: 00 33 (0)2 40 09 10 97

www.manitou.com



Esta publicación describe las versiones y posibilidades de configuración de los productos Manitou que puedan diferir en equipamiento. Los equipamientos presentados en este folleto pueden ser de serie, opcionales o no estar disponibles en algunas versiones. Manitou se reserva el derecho, en cualquier momento y sin previo aviso, de modificar las especificaciones descritas y representadas. Las especificaciones aportadas no comprometen al fabricante. Para más información, póngase en contacto con su concesionario Manitou. Documento no contractual. Presentación de los productos no contractual. Lista de especificaciones no exhaustiva. Los logos y la identidad visual de la empresa son propiedad de Manitou y no pueden ser utilizados sin autorización. Todos los derechos reservados. Las fotos y los esquemas contenidos en este folleto se ofrecen para consulta y a título indicativo solamente.

Manitou BF SA - Sociedad anónima con Consejo de Administración - Capital social: 39 668 399 euros - 857 802 508 RCS Nantes