

PINCA PARA FARDOS QUADRADOS EMBRULHADOS (MAQUINAS COMPACTAS)

GARRAS

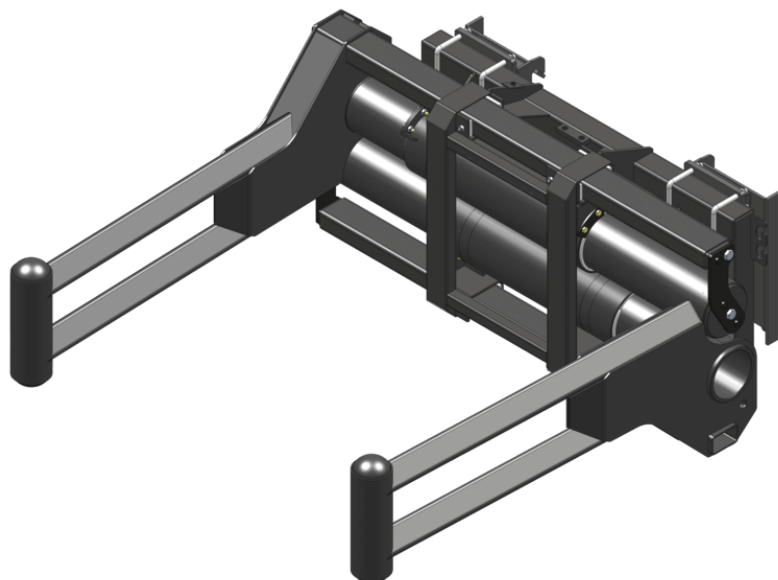

GEHL®

Benefícios para o cliente

- Estrutura tubular - sem risco de danificar o filme ao mover fardos embalados.
- Grande abertura de garras para manipulação de fardos grandes ou múltiplos.
- Proteção superior dos componentes.
- Multi-tarefa: projetado para fardos quadrados embalados, também pode lidar com fardos quadrados padrão ou fardos redondos.







Características técnicas

- Estrutura robusta & componentes para aplicações intensas.
- Cinemática telescópica - movimento suave & forte capacidade de fixação.
- Uso massivo de almofada de Teflon®.
- Manutenção limitada.
- Limitador de pressão padrão.

 **ATTACHMENTS**

| Capacities | | CLBSW 2000 / 1000 |
|---------------------------|-----|---|
| Capacidade (kg) | | 1000 |
| Weight | | |
| Peso (kg) | | 477 |
| Weight and dimensions | | |
| Altura total (mm) | h17 | 679 |
| Comprimento do braço (mm) | | 1811 |
| Working Parameters | | |
| Equipamento da máquina | |  |
| Abertura mínima (mm) | | 740 |
| Abertura máxima (mm) | | 2090 |

| Máquina de compatibilidades | | CLBSW 2000 / 1000 |
|-----------------------------|--|-------------------|
| All-Tach® | | NS1502694 |
| Engate de 4 pontos | | NS1502693 |
| Engate do tipo Euro | | NS1502692 |
| AL650 | | X |
| AL750 | | X |
| ALT750 | | X |
| MLA 6-65 H-Z | | X |
| MLA-T 516-75 H | | X |
| ALT750 OLD | | X |
| ALT750 OLD | | X |

| TABELA DE SÍMBOLOS | | | | | |
|---|--------------------------------|---|-----------------------------|---|---|
|  | Não é necessária predisposição |  | Linha hidráulica |  | Retorno hidráulico ao reservatório |
|  | Predisposição eléctrica |  | Predisposição da plataforma |  | Predisposição manipulador de pneus, do manipulador de cilindros |



GEHL®

Siège Social

P.O. Box 179 - One Gehl Way - West Bend, WI, USA 53095

Tel: (262) 334-9461 - Fax: (262) 338-7517

www.gehl.com



This brochure describes versions and configuration options for Gehl products which may be fitted with different equipment. The equipment described in this brochure may be standard, optional or not available depending on version. Gehl reserves the right to change the specifications shown and described at any time and without prior warning. The manufacturer is not liable for the specifications given. For more information, contact your Gehl dealer. Non-contractual document. Product descriptions may differ from actual products. List of specifications is not comprehensive. The logos and visual identity of the company are the property of Gehl and may not be used without authorization. All rights reserved. The photos and diagrams contained in this brochure are provided for information only.

MANITOU EQUIPMENT AMERICAS, LLC - Limited company with board of directors - Share capital: 39,668,399 euros - 857 802 508 RCS West Bend