

Технический паспорт ТЕХНИЧЕСКОЕ ОПИСАНИЕ :

ME 450 FOB



 **MANITOU**
HANDLING YOUR WORLD

| Technical characteristics | | Метрический | |
|---------------------------|---|-------------|--------------------------|
| 1.1 | Manufacturer | | Manitou |
| 1.2 | Model Name | | ME 450 FOB |
| 1.3 | Power source | | Electrical |
| 1.4 | Operator type | | Seated |
| 1.5 | Max. capacity | Q | 5000 kg |
| 1.6 | Load center of gravity | c | 500 mm |
| 1.8 | Load distance, centre of drive axle to fork | x | 500 mm |
| 1.9 | Wheelbase | y | 2000 mm |
| Weight | | | |
| 2.1 | Service weight | | 7100 kg |
| 2.2 | Weight on front axle (laden) / rear axle (laden) | | 10635 kg / 1465 kg |
| 2.3 | Weight on front axle (Unladen) / rear axle (Unladen) | | 3625 kg / 3475 kg |
| Wheels | | | |
| 3.1 | Tires type | | Solid tires |
| 3.2 | Dimensions of front wheels | | 250/15 |
| 3.3 | Dimensions of rear wheels | | 7.00-12 |
| 3.5 | Number of front wheels / rear wheels | | 2 / 2 |
| 3.5.2 | Number of drive wheels | | 2 |
| 3.6 | Front wheel gauge | b10 | 1130 mm |
| 3.7 | Rear wheel gauge | b11 | 1100 mm |
| Dimensions | | | |
| 4.7 | Height of overhead guard (cabin) | h6 | 2300 mm |
| 4.8 | Seat height/stand height | h7 | 1235 mm |
| 4.12 | Height of towing bar (coupling height) | h10 | 460 mm |
| 4.19 | Overall length | l1 | 4165 mm |
| 4.20 | Length to face of forks | l2 | 3015 mm |
| 4.21 | Overall width | b1 | 1380 mm |
| 4.22 | Forks section / width / length | s / e / l | 150 mm x 1150 mm x 50 mm |
| 4.23 | Fork carriage ISO 2328 (class/form) A/B | | 3A |
| 4.24 | Fork carriage width | b3 | 1100 mm |
| 4.31 | Ground clearance below mast | m1 | 110 mm |
| 4.32 | Ground clearance at centre of wheelbase | m2 | 219 mm |
| 4.33 | Aisle Width for pallets 1000 x 1200 crossways | Ast | 4475 mm |
| 4.34 | Aisle width for 800 x 1200 pallet lengthways | Ast | 4675 mm |
| 4.35 | Turning radius | Wa | 2720 mm |
| 4.36 | Internal turning radius (over tyres) | b13 | 805 mm |
| Performances | | | |
| 5.1 | Travel speed (laden / unladen) | | 13 km/h-13.50 km/h |
| 5.2 | Lifting speed (laden / unladen) | | 0.26 m/s-0.40 m/s |
| 5.3 | Lowering speed (laden / unladen) | | 0.50 m/s-0.30 m/s |
| 5.5 | Drawbar pull (Laden) | | 2700 daN |
| 5.7 | Gradeability (laden / unladen) | | 15 % / 16 % |
| 5.10 | Service brake | | Hydraulic |
| Engine | | | |
| 6.1 | Drive motor rating S2 60 min | | 16.60 kW |
| 6.2 | Lift motor rating at S3 15% | | 25.40 kW |
| 6.3 | Battery according to DIN 43531/35/36 A, B, C | | DIN43536 A |
| 6.4 | Battery voltage / capacity | | 80 V / 700 Ah |
| 6.6 | Energy consumption according to VDI cycle (kWh/h) | | 15.30 kWh/h |
| Miscellaneous | | | |
| 8.1 | Type of drive control | | Electronic |
| 8.2 | Working hydraulic pressure for attachments | | 210 bar |
| 8.3 | Oil flow rate for attachments | | 65 l/min |
| 8.4 | Measured/guaranteed mean noise level at the ear of the operator | | < 78 dB |

ME 450 FOB - габаритный чертеж

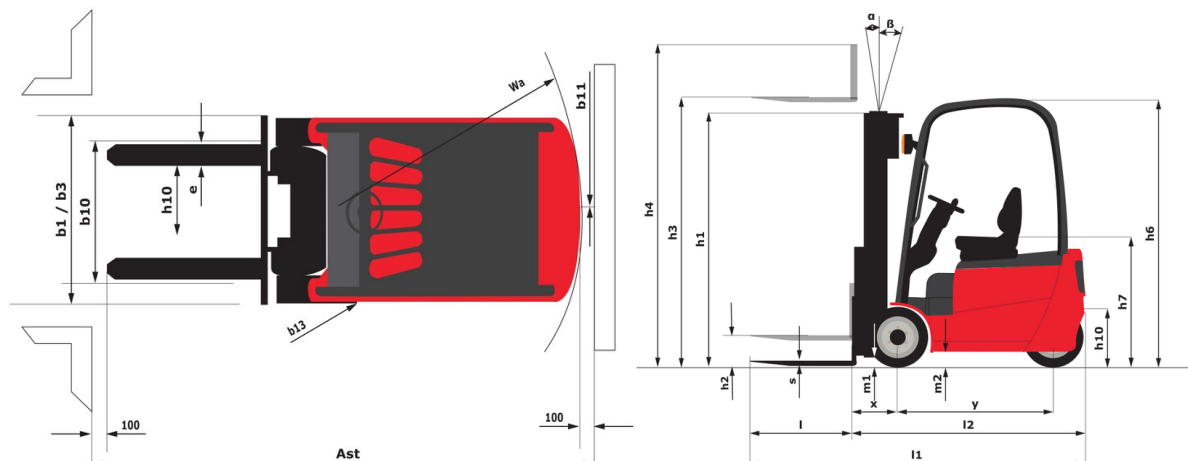

Характеристики мачт и начальная емкость

| Full Visibility Duplex (FVD) | FVD 30 | FVD 33 | FVD 35 | FVD 40 | FVD 43 | FVD 45 | FVD 48 | FVD 50 |
|---|--------|--------|--------|--------|--------|--------|--------|--------|
| α - Mast/fork carriage tilt, forward ° | 6 | 6 | 6 | 6 | 6 | 6 | 6 | 6 |
| β - Mast/fork carriage tilt, backward ° | 12 | 12 | 12 | 12 | 6 | 6 | 6 | 6 |
| h1 - Mast lowered height mm | 2185 | 2335 | 2435 | 2735 | 2900 | 3010 | 3175 | 3285 |
| h2 - Mast free lift mm | 150 | 150 | 150 | 150 | 150 | 150 | 150 | 150 |
| h3 - Mast lifting height mm | 3000 | 3300 | 3500 | 4000 | 4300 | 4500 | 4800 | 5000 |
| h4 - Mast extended height mm | 3770 | 4070 | 4270 | 4770 | 5070 | 5270 | 5570 | 5770 |
| Residual capacity at max height kg | 5000 | 5000 | 5000 | 5000 | 4950 | 4900 | 4800 | 4700 |
| Residual capacity with integrated side shift at max height kg | 5000 | 5000 | 5000 | 5000 | 4900 | 4850 | 4750 | 4650 |
| Residual capacity with hooked-on side shift at max height kg | 4800 | 4800 | 4800 | 4800 | 4700 | 4600 | 4500 | 4400 |
| Height at max capacity mm | 3000 | 3300 | 3500 | 4000 | 4000 | 4000 | 4000 | 4000 |
| Height at max capacity with integrated sideshift mm | 3000 | 3300 | 3500 | 4000 | 4000 | 4000 | 4000 | 4000 |

| Free Lift Duplex (FLD) | FLD 30 | FLD 33 | FLD 40 |
|---|--------|--------|--------|
| α - Mast/fork carriage tilt, forward ° | 6 | 6 | 6 |
| β - Mast/fork carriage tilt, backward ° | 12 | 12 | 12 |
| h1 - Mast lowered height mm | 2166 | 2316 | 2666 |
| h2 - Mast free lift mm | 1365 | 1515 | 1865 |
| h3 - Mast lifting height mm | 3000 | 3300 | 4000 |
| h4 - Mast extended height mm | 3805 | 4105 | 4805 |
| Residual capacity at max height kg | 5000 | 5000 | 5000 |
| Residual capacity with integrated side shift at max height kg | 5000 | 5000 | 5000 |
| Residual capacity with hooked-on side shift at max height kg | 4800 | 4800 | 4800 |
| Height at max capacity mm | 3000 | 3300 | 4000 |
| Height at max capacity with integrated sideshift mm | 3000 | 3300 | 4000 |

| Free Lift Triplex (FLT) | FLT 43 | FLT 48 | FLT 50 | FLT 55 | FLT 60 |
|---|--------|--------|--------|--------|--------|
| α - Mast/fork carriage tilt, forward ° | 6 | 6 | 6 | 3 | 3 |
| β - Mast/fork carriage tilt, backward ° | 6 | 6 | 6 | 6 | 6 |
| h1 - Mast lowered height mm | 2120 | 2280 | 2350 | 2515 | 2730 |
| h2 - Mast free lift mm | 1318 | 1478 | 1548 | 1710 | 1928 |
| h3 - Mast lifting height mm | 4300 | 4800 | 5000 | 5500 | 6000 |
| h4 - Mast extended height mm | 5105 | 5605 | 5805 | 6305 | 6805 |
| Residual capacity at max height kg | 4800 | 4650 | 4450 | 4250 | 4100 |
| Residual capacity with integrated side shift at max height kg | 4700 | 4600 | 4400 | 4200 | 4050 |
| Residual capacity with hooked-on side shift at max height kg | 4500 | 4350 | 4150 | 3950 | 3800 |
| Height at max capacity mm | 2500 | 2500 | 2500 | 2500 | 2500 |

**Головной офис**

В.Р. 249 - 430 rue de l'Aubinière

44150 Ancenis Cedex - France (Франция)

Телефон: 00 33 (0)2 40 09 10 11 - Факс: 00 33 (0)2 40 09 10 97

www.manitou.com

В данной брошюре описываются версии конфигурации и опции продуктов Manitou, которые могут отличаться в зависимости от оборудования. Описанное в данной брошюре оборудование может, в зависимости от версии, быть стандартным, опциональным или недоступным. Компания Manitou оставляет за собой право в любое время изменять приведенные и описанные характеристики без предварительного уведомления. Указанные технические характеристики не являются обязательными для производителя. Для получения дополнительной информации обратитесь к своему дилеру Manitou. Этот документ не имеет обязывающего, договорного характера. Описание продукции не имеет обязывающего, договорного характера. Список технических характеристик не является исчерпывающим. Логотипы и средства визуальной идентификации являются собственностью Manitou, их несанкционированное использование запрещено. Все права защищены. Фотографии и схемы в этой брошюре предоставлены только для ознакомления и в качестве справочной информации.

Manitou BF SA – Компания с ограниченной ответственностью и советом директоров – Акционерный капитал: 39 668 399 евро – Номер 857 802 508 в Реестре коммерсантов и предприятий Нанта