

Technical sheet :

# MT 625 H

---



 **MANITOU**  
HANDLING YOUR WORLD

Capacities		Metric
Max. capacity		2500 kg
Max. lifting height		5.85 m
Max. outreach		3.40 m
Breakout force with bucket		3427 daN
Weight and dimensions		
Overall length to carriage	l11	3.83 m
Length to face of forks	l2	3.90 m
Overall width	b1	1.81 m
Overall height	h17	1.92 m
Wheelbase	y	2.30 m
Ground clearance	m4	0.33 m
Overall cab width	b4	0.79 m
Tilt-up angle	a4	12 °
Tilt-down angle	a5	117 °
External turning radius (over tyres)	Wa1	3.31 m
Overall weight		4800 kg
Tires type		Pneumatic
Standard tires		CAMSO SKS532 12-16.5
Forks length / width / section	l / e / s	1200 mm x 125 mm x 45 mm
Performances		
Lifting		8 s
Lowering		5.40 s
Extension		5.60 s
Retraction		4.30 s
Crowd		3.50 s
Dump		3.60 s
Engine		
Engine brand		Kubota
Engine norm		Stage V
Engine model		V3307-CR-TE5B
Number of cylinders / Capacity of cylinders		4 - 3331 cm³
I.C. Engine power rating - Power		75 Hp / 55.40 kW
Max. torque / Engine rotation		265 Nm @ 1400 rpm
Drawbar pull (Laden)		3550 daN
Transmission		
Transmission type		Hydrostatic
Number of gears (forward / reverse)		2 / 2
Max. travel speed		24.90 km/h
Max. travel speed (may vary according to applicable regulations)		25 km/h
Parking brake		Automatic negative parking brake
Service brake		Oil-Immersed multi-discs braking on front axles
Hydraulics		
Hydraulic pump type		Gear pump
Hydraulic Pressure		235 bar
Tank capacities		
Engine oil		11.20 l
Hydraulic oil		115 l
Fuel tank		63 l
Noise and vibration		
Noise at driving position (LpA)		76 dB
Noise to environment (LWA)		104 dB
Vibration on hands/arms		< 2.50 m/s²
Miscellaneous		
Steering wheels (front / rear)		2 / 2
Drive wheels (front / rear)		2 / 2
Safety / Cab certification		Standard EN 15000 / ROPS - FOPS cab (level 1)
Controls		JSM

MT 625 H - Dimensional drawing

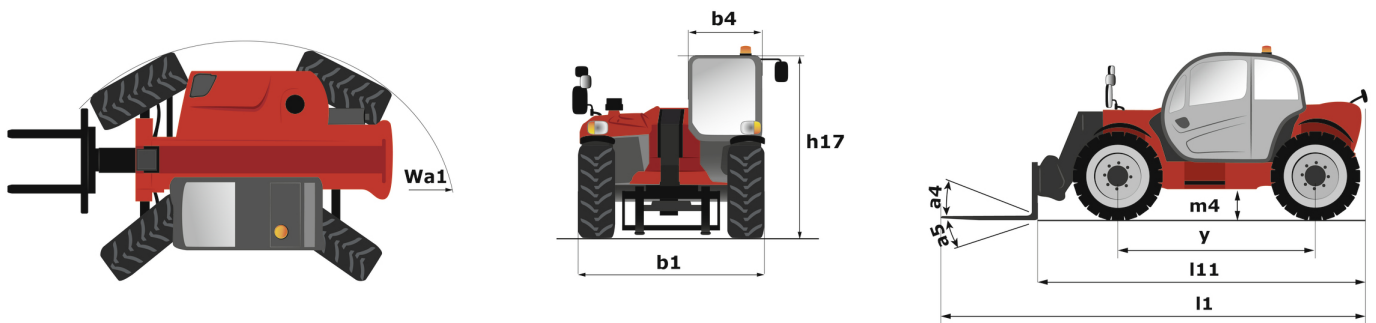

# MT 625 H - Load chart

Machine on tires with forks Metric

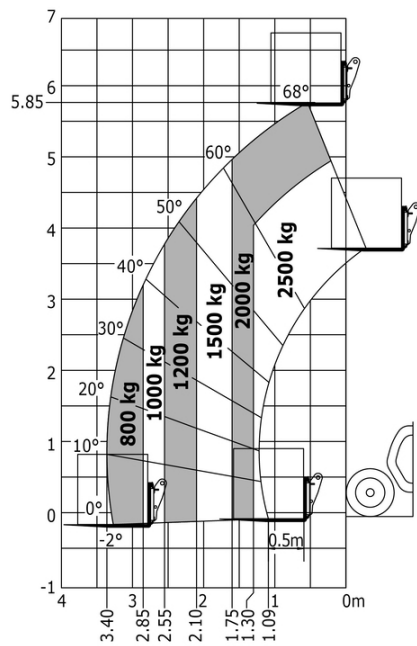

## Equipment

Standard
12V plug cigarette lighter type
Aggravating movements cut off EN 15000
Battery cut-off
Beacon
Bluetooth USB car radio with integrated microphone (100 W)
CAMSO SKS HAULER 12-16.5
Complete road lighting
Emergency stop
Floor mat
Mirror on rear of the machine
Rear electric plug
Rear wiper
Optional
Air suspension fabric seat - GRAMMER
Bluetooth USB car radio with extra microphone (100 W)
Bluetooth USB car radio with integrated microphone (100 W)
Car radio antenna
Document holder
Front and rear work lights on cab (x4)
Hydraulic line for quick-release attachments
Inner rear view mirror
Phone support
Sun visor on windshield and roof
Tuner car radio (50 W)



**Head Office**

B.P. 249 - 430 rue de l'Aubinière

44150 Ancenis Cedex - France

Tel: +33 (0)2 40 09 10 11 - Fax: +33 (0)2 40 09 10 97

[www.manitou.com](http://www.manitou.com)



This publication provides a description of the configuration versions and options for Manitou products, which may differ for equipment. The equipment presented in this brochure may be part of a series, as an option, or it may not be available, depending on the versions. Manitou reserves the right, at any time and without notice, to amend the specifications described and represented. The specifications provided do not bind the manufacturer. For more details, please contact your Manitou agent. This is not a contractually binding document. The presentation of the products is not contractually binding. List of specifications non-exhaustive. The logos as well as the visual identity of the company are owned by Manitou and cannot be used without authorisation. All rights reserved. The photos and diagrams contained in this brochure are only provided for consultation and information purposes.

MANITOU BF SA - Limited company with board of directors - Share capital: 39,668,399 euros - 857 802 508 RCS Nantes