

Scheda tecnica :

# M 50-2 D ST5



 **MANITOU**  
HANDLING YOUR WORLD

Technical characteristics		Metrico	
1.1	Manufacturer		MANITOU
1.2	Model Name		M 50-2 D ST5
1.3	Power source		Diesel
1.4	Operator type		Seated
1.5	Max. capacity	Q	5000 kg
1.6	Load center of gravity	c	600 mm
1.8	Load distance, centre of drive axle to fork	x	773 mm
1.9	Wheelbase	y	2060 mm
Weight			
2.1	Service weight		8275 kg
2.2	Weight on front axle (laden) / rear axle (laden)		11615 kg / 1660 kg
2.3	Weight on front axle (Unladen) / rear axle (Unladen)		3285 kg / 4990 kg
Wheels			
3.1	Tires type		Pneumatic
3.2	Dimensions of front wheels		18-19,5 18PR A224
3.3	Dimensions of rear wheels		10R17,5 G291 GY
3.5	Number of front wheels / rear wheels		2 / 2
3.5.2	Number of drive wheels		2
3.6	Front wheel gauge	b10	1600 mm
3.7	Rear wheel gauge	b11	1640 mm
Dimensions			
4.7	Height of overhead guard (cabin) / Overall height of low overhead guard (Buggie version)	h6 / h6*	2440 mm / 2440 mm
4.8	Seat height/stand height	h7	1407 mm
4.19	Overall length	l1	4948 mm
4.20	Length to face of forks	l2	3748 mm
4.21	Overall width	b1	2057 mm
4.22	Forks section x width x length	s / e / l	60 mm x 150 mm / 1200 mm
4.23	Fork carriage ISO 2328 (class/form) A/B		4A
4.24	Fork carriage width	b3	1670 mm
4.31	Ground clearance below mast	m1	250 mm
4.32	Ground clearance at centre of wheelbase	m2	377 mm
4.33	Aisle width for 1000 x 1200 pallet widthways	Ast	5640 mm
4.34	Aisle width for 800 x 1200 pallet lengthways	Ast	5640 mm
4.35	Turning radius	Wa	3465 mm
Performances			
5.1	Travel speed (laden / unladen)		22 km/h / 22 km/h
5.2	Lifting speed (laden / unladen)		0.40 m/s / 0.40 m/s
5.3	Lowering speed (laden / unladen)		0.50 m/s / 0.40 m/s
5.5	Drawbar pull (Laden)		6900 daN
5.7	Gradeability (laden)		51 %
5.10	Service brake		Hydraulic
Engine			
7.2	I.C. Engine power rating		55 kW
7.1	Engine brand / model / norm		Deutz / TCD 2,9 / Stage V
7.3	Rated speed		2300 rpm
7.4	Number of cylinders / Capacity of cylinders		4 - 2925 cm³
Miscellaneous			
8.2	Working hydraulic pressure for attachments		230 bar
8.3	Oil flow rate for attachments		97 l/min
8.4	Sound level at the driver's ear according to DIN 12 053		78 dB

M 50-2 D ST5 - Disegno quotato

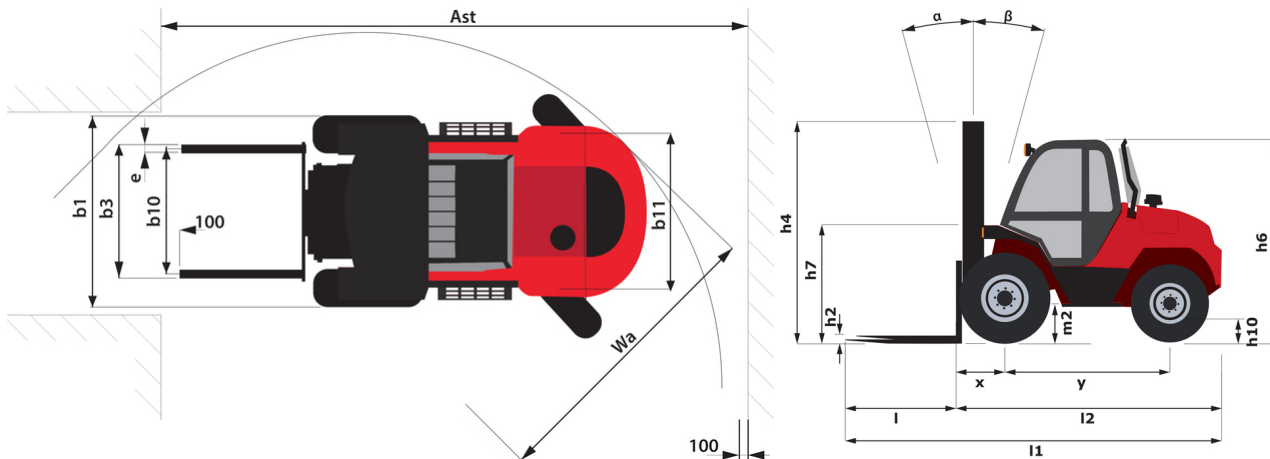

## Caratteristiche dei montanti e capacità residue

Full Visibility Duplex (FVD)		FVD 33	FVD 35	FVD 37	FVD 40	FVD 45	FVD 50
α - Mast/fork carriage tilt, forward	°	15	15	15	15	15	15
β - Mast/fork carriage tilt, backward	°	15	15	15	15	15	15
h1 - Mast lowered height	mm	2625	2725	2825	2975	3225	3475
h3 - Mast lifting height	mm	3300	3700	3700	4000	4500	5000
Residual capacity at max height	kg	5000	5000	5000	5000	4750	3500
Residual capacity with hooked-on side shift at max height	kg	4700	4700	4700	4700	4400	
Height at max capacity	mm	3300	3500	3700	4000	4000	4000
Height at max capacity with hooked-on sideshift	mm	3300	3500	3700	4000	4000	

Free Lift Triplex (FLT)		FLT 43	FLT 45	FLT 47	FLT 50	FLT 55	FLT 60
α - Mast/fork carriage tilt, forward	°	15	15	15	10	10	10
β - Mast/fork carriage tilt, backward	°	15	15	15	15	15	15
h1 - Mast lowered height	mm	2425	2500	2560	2675	2825	3000
h2 - Mast free lift	mm	1455	1530	1590	1705	1855	2030
h3 - Mast lifting height	mm	4300	4500	4700	5000	5500	6000
Residual capacity at max height	kg		4500	3500	2000	2000	
Residual capacity with hooked-on side shift at max height	kg	4400			3000	1600	250
Height at max capacity	mm	2500	4000	4000	3700	5500	2500
Height at max capacity with hooked-on sideshift	mm	3500			3700	3700	3200



 **MANITOU**  
**HANDLING YOUR WORLD**

**Sede centrale**

MANITOU ITALIA Srl

Via Cristoforo Colombo 2, Loc. Cavazzona - 41013 CASTELFRANCO EMILIA (MO)

Tel: 059.95.98.11 - Fax 059.95.98.65

[www.manitou.com](http://www.manitou.com)



Questa pubblicazione presenta la descrizione delle versioni e delle possibilità di configurazione dei prodotti Manitou, che possono differire per attrezzature. Gli allestimenti presentati nel presente opuscolo possono essere di serie, optional o non disponibili, a seconda delle versioni. Manitou si riserva il diritto di modificare, in qualsiasi momento e senza alcun preavviso, le specifiche tecniche descritte e rappresentate. Le specifiche indicate non rappresentano alcun obbligo per il costruttore. Per maggiori dettagli, rivolgersi al proprio concessionario Manitou. Documento non contrattuale. Elenco delle specifiche non esaustivo. I loghi nonché l'identità visiva dell'azienda sono di proprietà di Manitou e non possono essere utilizzati senza autorizzazione. Tutti i diritti riservati. Le immagini e gli schemi contenuti nel presente opuscolo sono forniti esclusivamente a fini di consultazione e a titolo indicativo.

Manitou BF SA - Società anonima con consiglio di amministrazione. Capitale sociale: 39,668,399 euro - 857 802 508 RCS Nantes