

Ficha técnica :

MLT-X 741 T LSU



 **MANITOU**
HANDLING YOUR WORLD

Capacities		Métrico
Max. capacity	Q	4100 kg
Max. lifting height	h3	6.90 m
Max. outreach		3.90 m
Reach at max. height		1 m
Breakout force with bucket		6825 daN
Weight and dimensions		
Unladen weight (with forks)		7450 kg
Ground clearance	m4	0.44 m
Wheelbase	y	2.81 m
Overall length to carriage (with hitch)	l11	4.99 m
Front overhang		1.19 m
Overall width	b1	2.40 m
Overall cab width	b4	0.98 m
Overall height	h17	2.30 m
Tilt-down angle	a5	134 °
Tilt-up angle	a4	13 °
External turning radius (over tyres)	Wa1	3.86 m
Standard tires		Firestone - R8000 UT - 460/70 R24 159A8
Performances		
Lifting		8.10 s
Lowering		6.20 s
Extension		8.40 s
Retraction		6.80 s
Crowd		3.80 s
Dump		3.20 s
Engine		
Engine brand		Perkins
Engine norm		Stage IIIA
Engine model		1104D-44 T
Number of cylinders - Capacity of cylinders		4 - 4400 cm³
I.C. Engine power rating / Power		101 Hp / 74.50 kW
Max. torque / Engine rotation		410 Nm @1600 rpm
Drawbar pull (Laden)		8200 daN
Reversible fan		Standard
Engine cooling system		3 radiators water + intercooler + transmission oil
Transmission		
Transmission type		Torque converter
Gearbox		Powershuttle
Number of gears (forward / reverse)		4 / 4
Max. travel speed (may vary according to applicable regulations)		35 km/h
Differential lock		Limited slip differential on front axle
Parking brake		Mechanical hand-operated parking brake
Service brake		Oil-immersed multi-discs braking on front & rear axles
Hydraulics		
Hydraulic pump type		Variable displacement pump
Hydraulic flow - Pressure		108 l/min - 270 bar
Flow sharing distributor		Standard
Tank capacities		
Hydraulic tank capacity		135 l
Fuel tank		142 l
Noise and vibration		
Noise at driving position (LpA) tested following NF EN 12053 norm		76 dB
Noise to environment (LwA)		104 dB
Vibration on hands/arms		< 2.50 m/s²
Miscellaneous		
Tractor homologation		Tractor homologation
Safety cab homologation		Cabin ROPS - FOPS level 2
Controls		JSM

Optional tires tab

	Overall height	Overall width
ALLIANCE - A570 - 17,5 LR24	-	-
ALLIANCE - A580 - 460/70 R24 159A8	2.30 m	2.40 m
MICHELIN - XHA - 15.5 R25	-	-
MICHELIN - XMCL - 500/70 R24 164A8	2.30 m	2.41 m
NOKIAN - TRI STEEL - 460/65 R24 156A8	2.27 m	2.38 m

MLT-X 741 T LSU - Diagrama dimensional

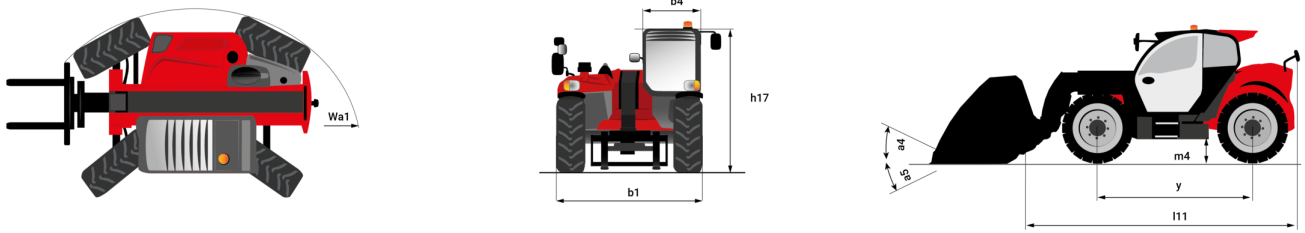

MLT-X 741 T LSU - Diagramas de carga

Machine on tires with forks Metric

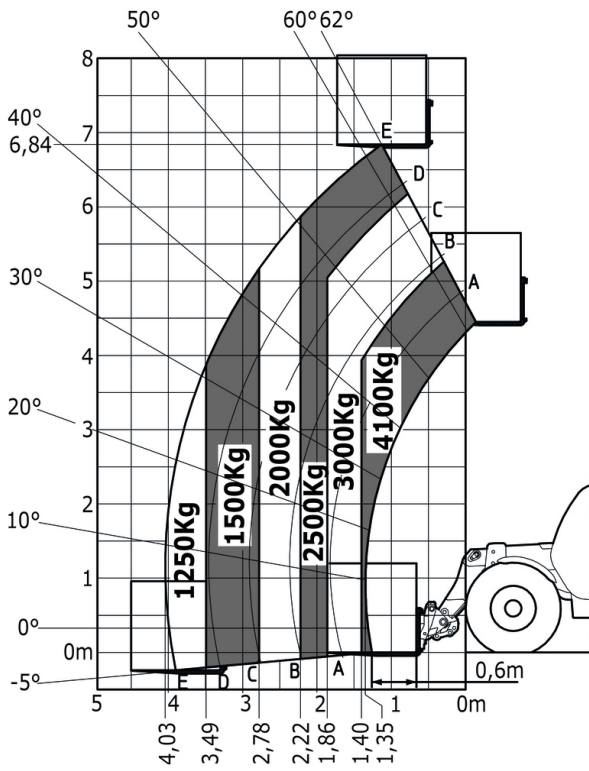



Oficina Central

B.P. 249 - 430 rue de l'Aubinière

44150 Ancenis Cedex - Francia

Tel.: 00 33 (0)2 40 09 10 11 - Fax: 00 33 (0)2 40 09 10 97

www.manitou.com



Esta publicación describe las versiones y posibilidades de configuración de los productos Manitou que puedan diferir en equipamiento. Los equipamientos presentados en este folleto pueden ser de serie, opcionales o no estar disponibles en algunas versiones. Manitou se reserva el derecho, en cualquier momento y sin previo aviso, de modificar las especificaciones descritas y representadas. Las especificaciones aportadas no comprometen al fabricante. Para más información, póngase en contacto con su concesionario Manitou. Documento no contractual. Presentación de los productos no contractual. Lista de especificaciones no exhaustiva. Los logos y la identidad visual de la empresa son propiedad de Manitou y no pueden ser utilizados sin autorización. Todos los derechos reservados. Las fotos y los esquemas contenidos en este folleto se ofrecen para consulta y a título indicativo solamente.

Manitou BF SA - Sociedad anónima con Consejo de Administración - Capital social: 39 668 399 euros - 857 802 508 RCS Nantes