

Technical sheet :

MXT 840 P IND



 **MANITOU**
HANDLING YOUR WORLD

Capacities		Metric
Max. capacity	Q	4000 kg
Max. lifting height		7600 mm
Maximum outreach		4230 mm
Weight and dimensions		
Overall length to carriage	l11	4596 mm
Length to face of forks	l2	4676 mm
Overall length (with forks)	l1	5876 mm
Overall width	b1	2387 mm
Overall height	h17	2595 mm
Wheelbase	y	2582 mm
Ground clearance	m4	372 mm
Overall cab width	b4	850 mm
Tilt-up angle	a4	12 °
Tilt-down angle	a5	134 °
External turning radius (over tyres)	Wa1	3900 mm
Unladen weight (with forks)		8500 kg
Tires type		Inflatable
Standard tires		BKT 16.0/70-20 14PR- EM936 SPL
Forks length / width / section	l / e / s	1200 mm x 125 mm x 50 mm
Performances		
Lifting		12.70 s
Lowering		9 s
Extension		9.20 s
Retraction		6.20 s
Dump		3.90 s
Engine		
Engine brand		Perkins
Engine norm		Stage IIIA
Engine model		1104D-44T
Number of cylinders / Capacity of cylinders		4 - 4400 cm³
Engine power (Hp/kW)		94 Hp / 70 kW
Max. torque / Engine rotation		392 Nm @ 1400 rpm
Drawbar pull		7800 daN
Drawbar pull (Laden)		7800 daN
Engine/Battery		
Battery technology		Lead acid
Battery capacity		130 Ah
Electric circuit		
Battery voltage / capacity		12 V / 130 Ah
Transmission		
Transmission type		Torque converter
Number of gears (forward / reverse)		4 / 4
Max. travel speed		26 km/h
Max. travel speed (may vary according to applicable regulations)		26 km/h
Parking brake		Oil-Immersed Multi-Disc Braking front and rear Axle
Service brake		Oil-immersed multi-discs braking on front & rear axles
Hydraulics		
Hydraulic pump type		Gear pump
Hydraulic flow / Pressure		91.40 l/min-250 bar
Tank capacities		
Engine oil		10 l
Hydraulic oil		125 l
Fuel		100 l
Noise and vibration		
Noise at driving position (LpA)		85 dB
Noise to environment (LWA)		110 dB
Miscellaneous		
Steering wheels (front / rear)		2 / 2
Drive wheels (front / rear)		2 / 2
Cab certification		Cabin ROPS - FOPS level 2

MXT 840 P IND - Dimensional drawing

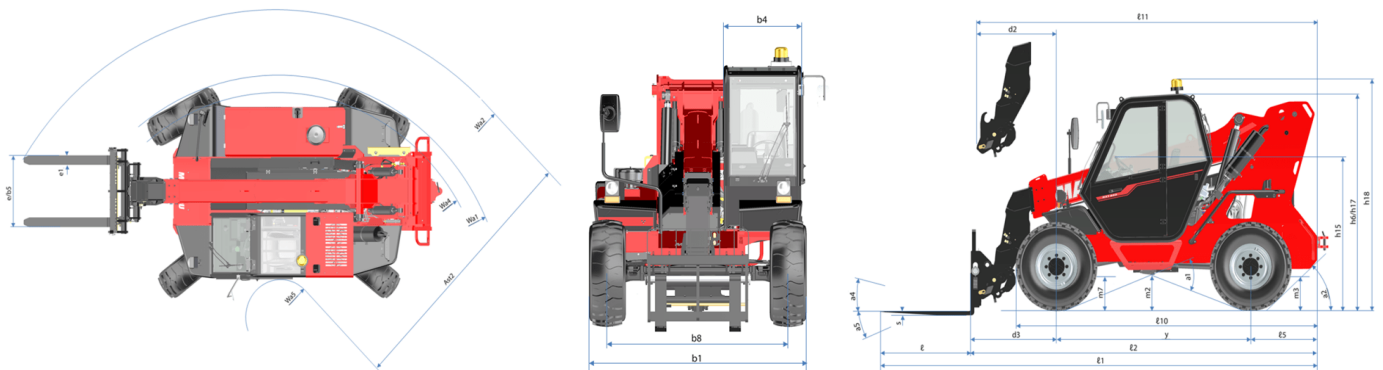

MXT 840 P IND - Load chart

Machine on tires with forks Metric





Head Office

B.P. 249 - 430 rue de l'Aubinière
44150 Ancenis Cedex - France

Tel: +33 (0)2 40 09 10 11 - Fax: +33 (0)2 40 09 10 97

www.manitou.com



This publication provides a description of the configuration versions and options for Manitou products, which may differ for equipment. The equipment presented in this brochure may be part of a series, as an option, or it may not be available, depending on the versions. Manitou reserves the right, at any time and without notice, to amend the specifications described and represented. The specifications provided do not bind the manufacturer. For more details, please contact your Manitou agent. This is not a contractually binding document. The presentation of the products is not contractually binding. List of specifications non-exhaustive. The logos as well as the visual identity of the company are owned by Manitou and cannot be used without authorisation. All rights reserved. The photos and diagrams contained in this brochure are only provided for consultation and information purposes.

MANITOU BF SA - Limited company with board of directors - Share capital: 39,668,399 euros - 857 802 508 RCS Nantes