

Scheda tecnica :

TMT 251 Y ST5



 **MANITOU**
HANDLING YOUR WORLD

	Specifiche tecniche		Metrico
1.1	Costruttore		MANITOU
1.2	Nome modello		TMT 25I Y ST5
1.2.1	Estensione equipaggiamento		Braccio telescopico
1.3	Tipo di alimentazione		Diesel
1.4	Tipo di operatore		Seduto
1.5	Portata massima	Q	2500 kg
1.6	Baricentro del carico	c	600 mm
1.8	Distanza dal centro dell'asse anteriore al piano forche	x	-505 mm
1.9	Interasse	y	1784 mm
	Weight		
2.1	Peso		2320 kg
	Pneumatici		
3.1	Tipo di ruote		Gomme pneumatiche antitraccia
3.2	Dimensioni ruote anteriori		18x7-8
3.3	Dimensioni ruote posteriori		10x16,5
3.5	Numero ruote anteriori / di ruote posteriori		2 / 1
3.5.2	Ruote motrici (anteriori / posteriori)		2 / 1
3.6	Carreggiata centro ruote anteriori	b10	2102 mm
	Dimensions		
4.1	Inclinazione del montante e del portaforche, in avanti	α	100 °
4.1.1	Inclinazione del montante e del portaforche, indietro	β	12 °
4.2	Altezza braccio telescopico abbassato	h1	2240 mm
4.3	Alzata libera	h2	1440 mm
4.4	Altezza massima di sollevamento	h3	3380 mm
4.5	Altezza braccio telescopico esteso	h4	3925 mm
4.7	Altezza della protezione conducente (cabina)	h6	2200 mm
4.8	Altezza del sedile	h7	1220 mm
4.19	Lunghezza totale	l1	2790 mm
4.20	Lunghezza al piano forche	l2	1590 mm
4.21	Larghezza	b1	2266 mm
4.22	Sezione forche / Larghezza forche / Lunghezza forche	s / e / l	40 mm x 125 mm x 1200 mm
4.23	Piastra portaforche a norma DIN 15173 A/B		FEM 2A
4.24	Larghezza della piastra portaforche	b3	1270 mm
4.26	Scartamento longheroni	b5	1267 mm
4.26	Distanza tra longheroni delle ruote/superfici di carico	b4	1634 mm
4.28	Massima estensione orizzontale al centro di gravità 600	l4	1310 mm
4.32	Altezza dal suolo al centro dell'interasse	m2	278 mm
4.33	Corridoio di lavoro con pallet 1000 x 1200 trasversale	Ast	3970 mm
4.34	Corridoio di lavoro con pallet 800 x 1200 longitudinale	Ast	3970 mm
4.35	Raggio di sterzata	Wa	3011 mm
	Performance		
5.2	Velocità di sollevamento (con carico / senza carico)		0.25 m/s / 0.27 m/s
5.3	Velocità discesa con carico / (senza carico)		0.29 m/s / 0.32 m/s
5.10	Freno di servizio		Freni idraulici per mancanza di pressione
	Motore		
7.1	Marca motore / Norma motore / Modello motore		Yanmar - Stage V / 3TNV 86 CT
7.2	Potenza nominale motore (cv) / Potenza		42 cv / 31 kW
7.3	Regime nominale		2800 rpm
7.4	Numero di cilindri / Cilindrata		3 - 1568 cm ³
	Varie		
8.1	Tipo di unità motrice		Meccanico
8.2	Pressione impianto idraulico per accessori		270 bar
8.3	Portata d'olio per attrezzature		44 l/min
8.4	Livello medio della rumorosità all' orecchio del conduttore misurata/garantita		104 dB

TMT 25I Y ST5 - Disegno quotato

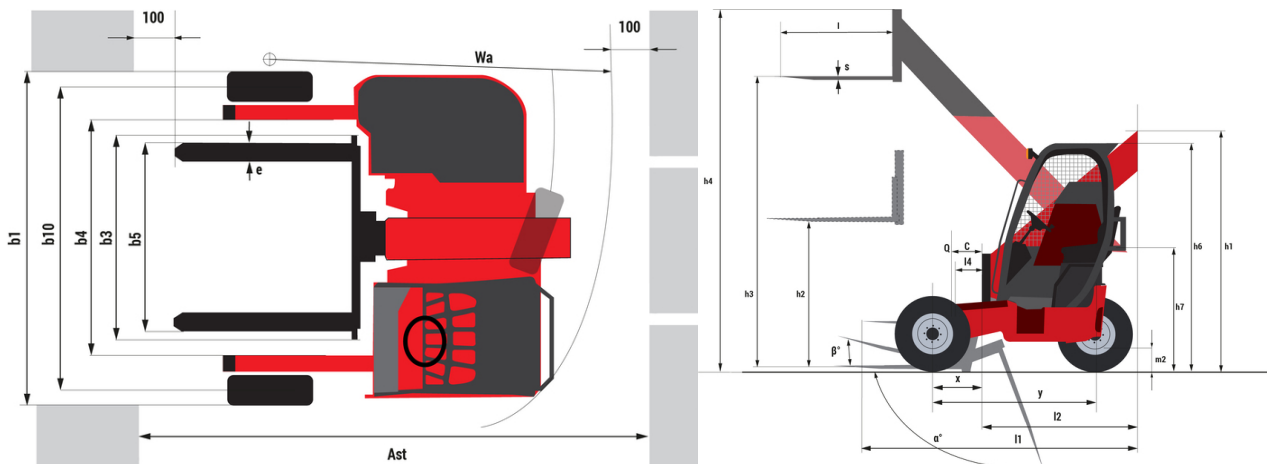

TMT 25I Y ST5 - Diagramma di carico

Macchina su pneumatici con forche

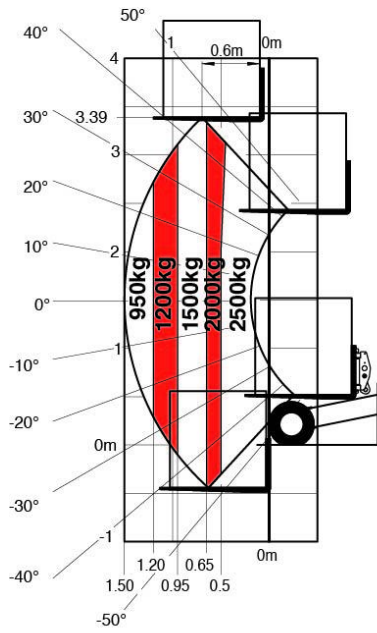

SUIVANT NORME EN 1459 annexe A.



N°285160



 **MANITOU**
HANDLING YOUR WORLD

Sede centrale

MANITOU ITALIA Srl

Via Cristoforo Colombo 2, Loc. Cavazzona - 41013 CASTELFRANCO EMILIA (MO)

Tel: 059.95.98.11 - Fax 059.95.98.65

www.manitou.com



Questa pubblicazione presenta la descrizione delle versioni e delle possibilità di configurazione dei prodotti Manitou, che possono differire per attrezzature. Gli allestimenti presentati nel presente opuscolo possono essere di serie, optional o non disponibili, a seconda delle versioni. Manitou si riserva il diritto di modificare, in qualsiasi momento e senza alcun preavviso, le specifiche tecniche descritte e rappresentate. Le specifiche indicate non rappresentano alcun obbligo per il costruttore. Per maggiori dettagli, rivolgersi al proprio concessionario Manitou. Documento non contrattuale. Elenco delle specifiche non esaustivo. I loghi nonché l'identità visiva dell'azienda sono di proprietà di Manitou e non possono essere utilizzati senza autorizzazione. Tutti i diritti riservati. Le immagini e gli schemi contenuti nel presente opuscolo sono forniti esclusivamente a fini di consultazione e a titolo indicativo.

Manitou BF SA - Società anonima con consiglio di amministrazione. Capitale sociale: 39,668,399 euro - 857 802 508 RCS Nantes