

Technical sheet :

TMT 55 XT Y ST5



 **MANITOU**
HANDLING YOUR WORLD

Technical characteristics		Imperial	
1.1	Manufacturer		Manitou
1.2	Model Name		TMT 55 XT Y ST5
1.2.1	Reach out equipment		Telescopic boom
1.3	Power source		Diesel
1.4	Operator type		Seated
1.5	Max. capacity	Q	5512 lb
1.6	Load center of gravity	c	24 in
1.8	Load distance, centre of drive axle to fork	x	-20 in
1.9	Wheelbase	y	65 in
Weight			
2.1	Service weight		6085 lb
Wheels			
3.1	Tires type		Pneumatic
3.2	Dimensions of front wheels		31 x 15,5 - 15"
3.3	Dimensions of rear wheels		31 x 15,5 - 15"
3.5	Number of front wheels / rear wheels		2 / 1
3.5.2	Drive wheels (front / rear)		2 / 1
3.6	Front wheel gauge	b10	86 in
Dimensions			
4.1	Mast/fork carriage tilt, forward		100 °
4.1.1	Mast/fork carriage tilt, backward		12 °
4.2	Height telescopic boom lowered	h1	89 in
4.3	Mast free lift	h2	57 in
4.4	Max. lifting height	h3	135 in
4.5	Height telescopic boom extended	h4	155 in
4.7	Height of overhead guard (cabin)	h6	93 in
4.8	Seat height/stand height	h7	55 in
4.19	Overall length	l1	111 in
4.20	Length to face of forks	l2	63 in
4.21	Overall width	b1	101 in
4.22	Forks section / width / length	s / e / l	2 in x 4 in x 48 in
4.23	Fork carriage ISO 2328 (class/form) A/B		FEM 2A
4.24	Fork carriage width	b3	50 in
4.26	Distance between support arms	b4	49 in
4.26	Distance between wheel arms/loading surfaces	b4	60 in
4.32	Ground clearance at centre of wheelbase	m2	16 in
4.33	Aisle Width for pallets 1000 x 1200 crossways	Ast	79 in
4.34	Aisle width for 800 x 1200 pallet lengthways	Ast	75 in
4.35	Turning radius	Wa	118 in
Performances			
5.2	Lifting speed (laden / unladen)		0.82 ft/s / 0.89 ft/s
5.3	Lowering speed (laden / unladen)		0.95 ft/s / 1 ft/s
5.10	Service brake		Hydraulic brakes by loss of pressure
Engine			
7.1	Engine brand / norm		Yanmar - Stage V
	I.C. Engine power rating		31 kW
7.3	Rated speed		2800 rpm
7.4	Number of cylinders / Capacity of cylinders		3 - 96 in³
Miscellaneous			
8.1	Type of drive control		Mechanical
8.2	Working hydraulic pressure for attachments		3916 PSI
8.3	Oil flow rate for attachments		12 US gpm
8.4	Measured/guaranteed mean noise level at the ear of the operator		105 dB

TMT 55 XT Y ST5 - Dimensional drawing

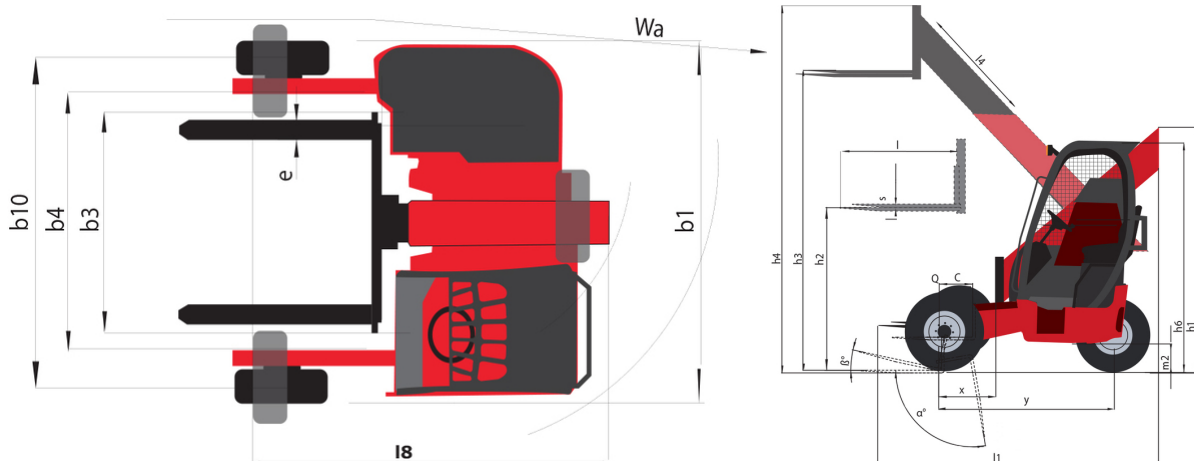

TMT 55 XT Y ST5 - Load chart

Machine on tyres with forks Imperial

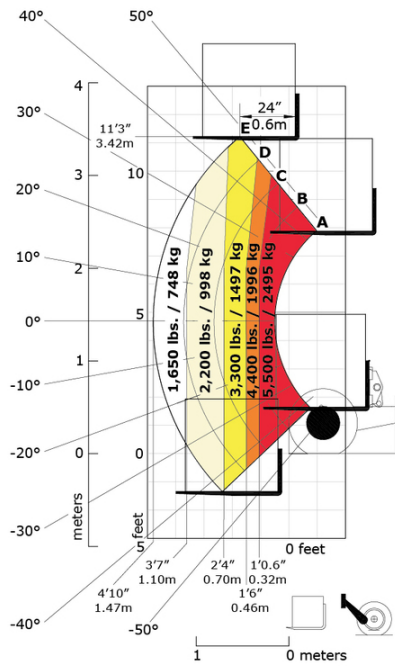

Machine on lowered stabilisers with forks Imperial

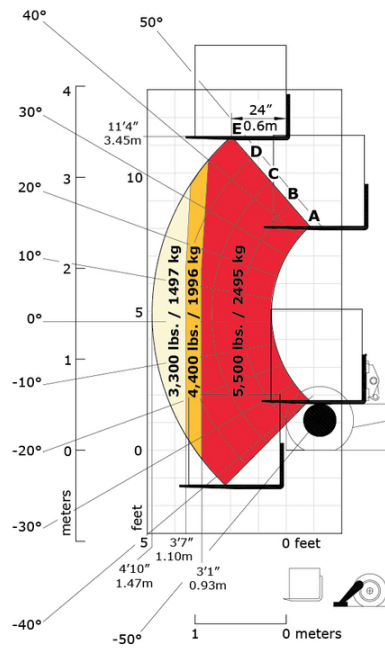



Head Office

B.P. 249 - 430 rue de l'Aubinière

44150 Ancenis Cedex - France

Tel: +33 (0)2 40 09 10 11 - Fax: +33 (0)2 40 09 10 97

www.manitou.com



This publication provides a description of the configuration versions and options for Manitou products, which may differ for equipment. The equipment presented in this brochure may be part of a series, as an option, or it may not be available, depending on the versions. Manitou reserves the right, at any time and without notice, to amend the specifications described and represented. The specifications provided do not bind the manufacturer. For more details, please contact your Manitou agent. This is not a contractually binding document. The presentation of the products is not contractually binding. List of specifications non-exhaustive. The logos as well as the visual identity of the company are owned by Manitou and cannot be used without authorisation. All rights reserved. The photos and diagrams contained in this brochure are only provided for consultation and information purposes.

MANITOU BF SA - Limited company with board of directors - Share capital: 39,668,399 euros - 857 802 508 RCS Nantes