

Ficha técnica :

MT-X 735



 **MANITOU**
HANDLING YOUR WORLD

| Capacities | | Métrico |
|--|-----------|---|
| Max. capacity | | 3500 kg |
| Max. lifting height | | 6.90 m |
| Max. outreach | | 4 m |
| Breakout force with bucket | | 6980 daN |
| Weight and dimensions | | |
| Overall length to carriage | l11 | 4.70 m |
| Overall length (with forks) | l1 | 5.98 m |
| Overall width | b1 | 2.26 m |
| Overall height | h17 | 2.48 m |
| Wheelbase | y | 2.80 m |
| Ground clearance | m4 | 0.36 m |
| Overall cab width | b4 | 0.95 m |
| Tilt-up angle | a4 | 13 ° |
| Tilt-down angle | a5 | 114 ° |
| External turning radius (over tyres) | Wa1 | 3.77 m |
| Unladen weight (with forks) | | 6970 kg |
| Unladen weight | | 6660 kg |
| Tires type | | Pneumatic |
| Standard tires | | Apollo 400/80 - 24 - 162A8 |
| Forks length / width / section | l / e / s | 1200 mm x 100 mm x 50 mm |
| Performances | | |
| Lifting | | 6.60 s |
| Lowering | | 5 s |
| Extension | | 5.90 s |
| Retraction | | 4.60 s |
| Crowd | | 3.10 s |
| Dump | | 3.10 s |
| Engine | | |
| Engine brand | | Perkins |
| Engine norm | | Stage IIIA |
| Engine model | | 1104D-44T NL85156 |
| Number of cylinders / Capacity of cylinders | | 4 - 4400 cm ³ |
| I.C. Engine power rating - Power | | 95 Hp / 70 kW |
| Max. torque / Engine rotation | | 392 Nm @ 1400 rpm |
| Drawbar pull | | 5650 daN |
| Drawbar pull (Laden) | | 8050 daN |
| Electric circuit | | |
| 12V Battery capacity | | 110 Ah |
| Transmission | | |
| Transmission type | | Torque converter |
| Number of gears (forward / reverse) | | 4 / 4 |
| Max. travel speed | | 25 km/h |
| Max. travel speed (may vary according to applicable regulations) | | 24.50 km/h |
| Parking brake | | Automatic parking brake |
| Service brake | | Hydraulic servo brake |
| Hydraulics | | |
| Hydraulic pump type | | Axial piston |
| Hydraulic Pressure | | 260 bar |
| Tank capacities | | |
| Engine oil | | 11.40 l |
| Hydraulic oil | | 129 l |
| Fuel tank | | 103 l |
| Noise and vibration | | |
| Noise at driving position (LpA) | | 82 dB |
| Noise to environment (LwA) | | 105 dB |
| Vibration on hands/arms | | < 2.50 m/s ² |
| Miscellaneous | | |
| Steering wheels (front / rear) | | 2 / 2 |
| Drive wheels (front / rear) | | 2 / 2 |
| Safety / Safety cab homologation | | Standard EN 15000 / Cabin ROPS - FOPS level 2 |
| Controls | | JSM |

MT-X 735 - Diagrama dimensional

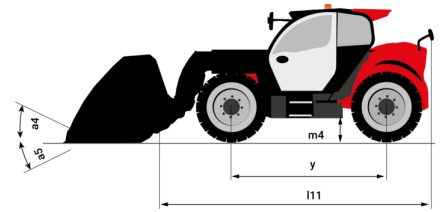
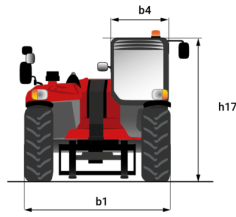
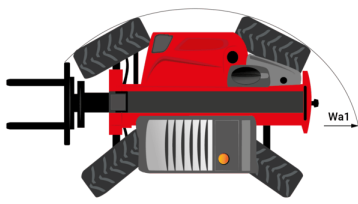

MT-X 735 - Diagramas de carga

Machine on tires with forks Metric

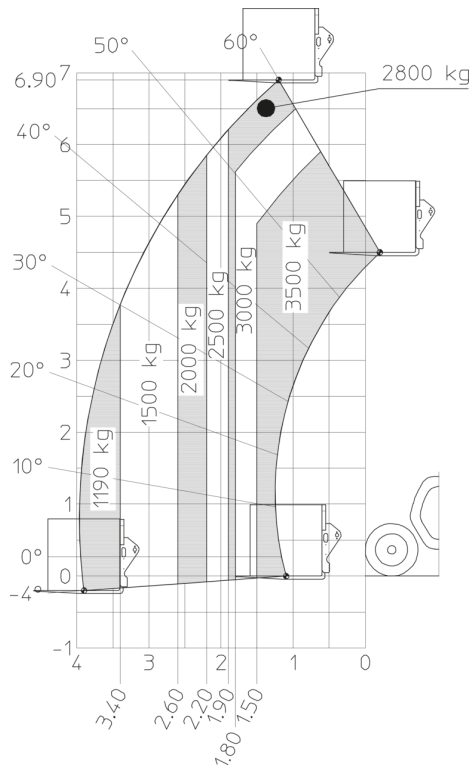



Oficina Central

B.P. 249 - 430 rue de l'Aubinière

44150 Ancenis Cedex - Francia

Tel.: 00 33 (0)2 40 09 10 11 - Fax: 00 33 (0)2 40 09 10 97

www.manitou.com



Esta publicación describe las versiones y posibilidades de configuración de los productos Manitou que puedan diferir en equipamiento. Los equipamientos presentados en este folleto pueden ser de serie, opcionales o no estar disponibles en algunas versiones. Manitou se reserva el derecho, en cualquier momento y sin previo aviso, de modificar las especificaciones descritas y representadas. Las especificaciones aportadas no comprometen al fabricante. Para más información, póngase en contacto con su concesionario Manitou. Documento no contractual. Presentación de los productos no contractual. Lista de especificaciones no exhaustiva. Los logos y la identidad visual de la empresa son propiedad de Manitou y no pueden ser utilizados sin autorización. Todos los derechos reservados. Las fotos y los esquemas contenidos en este folleto se ofrecen para consulta y a título indicativo solamente.

Manitou BF SA - Sociedad anónima con Consejo de Administración - Capital social: 39 668 399 euros - 857 802 508 RCS Nantes