

Ficha técnica :

# MT-X 1135



 **MANITOU**  
HANDLING YOUR WORLD

Capacities		Métrico
Max. capacity		3500 kg
Max. lifting height		10.85 m
Max. outreach		7.30 m
Breakout force with bucket		6850 daN
Weight and dimensions		
Overall length to carriage	l11	5.14 m
Overall length (with forks)	l1	6.34 m
Overall width	b1	2.26 m
Overall height	h17	2.48 m
Wheelbase	y	2800 mm
Ground clearance	m4	0.36 m
Overall cab width	b4	0.95 m
Tilt-up angle	a4	13 °
Tilt-down angle	a5	114 °
External turning radius (over tyres)	Wa1	3.77 m
Unladen weight (with forks)		8810 kg
Overall weight		8810 kg
Tires type		Pneumatic
Standard tires		Apollo 400/80 - 24 - 162A8
Forks length / width / section	l / e / s	1200 mm x 100 mm x 50 mm
Performances		
Lifting		7.60 s
Lowering		5.40 s
Extension		12.30 s
Retraction		8.20 s
Crowd		3.10 s
Dump		3.60 s
Engine		
Engine brand		Perkins
Engine norm		Stage IIIA
Engine model		1104D-44T
Number of cylinders / Capacity of cylinders		4 - 4400 cm <sup>3</sup>
I.C. Engine power rating - Power		95 Hp / 70 kW
Max. torque / Engine rotation		392 Nm @ 1400 rpm
Drawbar pull		6300 daN
Drawbar pull (Laden)		8350 daN
Electric circuit		
12V Battery capacity		110 Ah
Transmission		
Transmission type		Torque converter
Number of gears (forward / reverse)		4 / 4
Max. travel speed		25 km/h
Parking brake		Automatic parking brake
Service brake		Hydraulic servo brake
Hydraulics		
Hydraulic pump type		Axial piston
Hydraulic Pressure		270 bar
Tank capacities		
Engine oil		11.40 l
Hydraulic oil		149 l
Fuel tank		103 l
Noise and vibration		
Noise at driving position (LpA)		82 dB
Noise to environment (LwA)		105 dB
Vibration on hands/arms		< 2.50 m/s <sup>2</sup>
Miscellaneous		
Steering wheels (front / rear)		2 / 2
Drive wheels (front / rear)		2 / 2
Safety / Safety cab homologation		Standard EN 15000 / Cabin ROPS - FOPS level 2
Controls		JSM

### MT-X 1135 - Diagrama dimensional

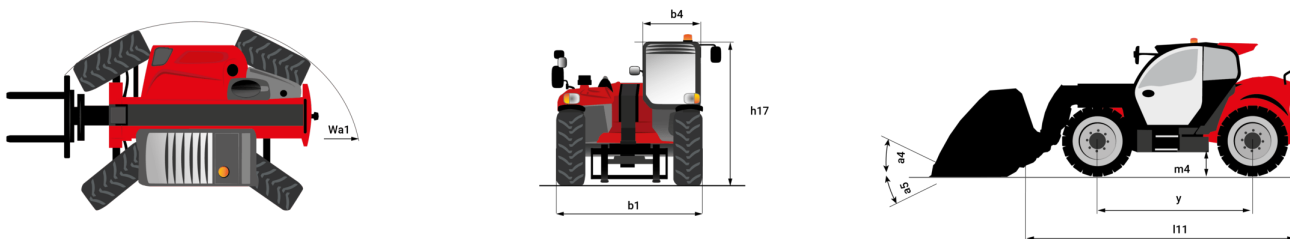

### MT-X 1135 - Diagramas de carga

Machine on tires with forks Metric

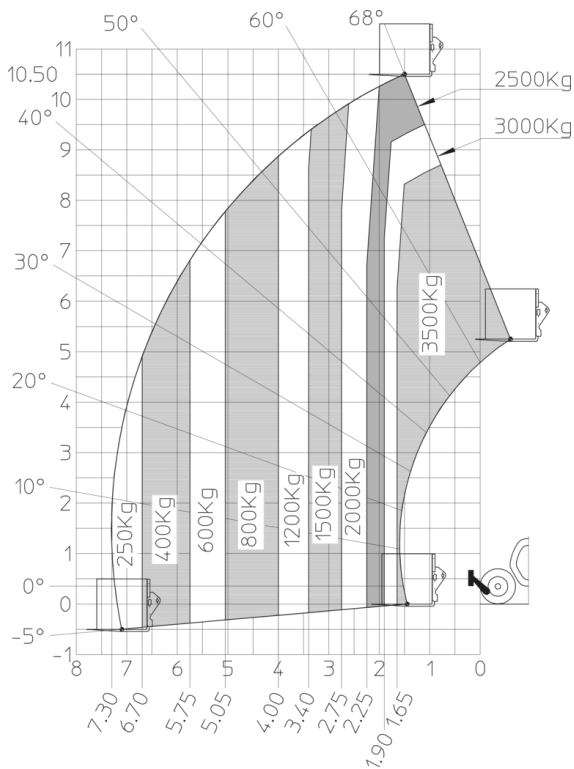

Machine on lowered stabilisers with forks Metric

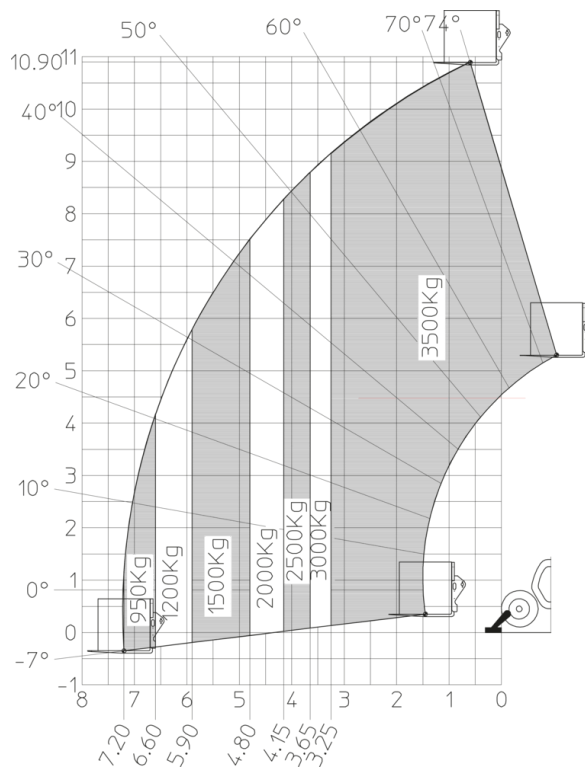



**Oficina Central**

B.P. 249 - 430 rue de l'Aubinière

44150 Ancenis Cedex - Francia

Tel.: 00 33 (0)2 40 09 10 11 - Fax: 00 33 (0)2 40 09 10 97

[www.manitou.com](http://www.manitou.com)



Esta publicación describe las versiones y posibilidades de configuración de los productos Manitou que puedan diferir en equipamiento. Los equipamientos presentados en este folleto pueden ser de serie, opcionales o no estar disponibles en algunas versiones. Manitou se reserva el derecho, en cualquier momento y sin previo aviso, de modificar las especificaciones descritas y representadas. Las especificaciones aportadas no comprometen al fabricante. Para más información, póngase en contacto con su concesionario Manitou. Documento no contractual. Presentación de los productos no contractual. Lista de especificaciones no exhaustiva. Los logos y la identidad visual de la empresa son propiedad de Manitou y no pueden ser utilizados sin autorización. Todos los derechos reservados. Las fotos y los esquemas contenidos en este folleto se ofrecen para consulta y a título indicativo solamente.

Manitou BF SA - Sociedad anónima con Consejo de Administración - Capital social: 39 668 399 euros - 857 802 508 RCS Nantes