

Scheda tecnica :

ME 425 LIFT



 **MANITOU**
HANDLING YOUR WORLD

Technical characteristics		Metrico	
1.1	Manufacturer		Manitou
1.2	Model Name		ME 425 LIFT
1.3	Power source		Electrical
1.4	Operator type		Seated
1.5	Max. capacity	Q	2500 kg
1.6	Load center of gravity	c	500 mm
1.8	Load distance, centre of drive axle to fork	x	431 mm
1.9	Wheelbase	y	1520 mm
	Standard mast reference of the machine		FVD 30
Weight			
2.1	Service weight		3875 kg
2.2	Weight on front axle (laden) / rear axle (laden)		5595 kg / 780 kg
2.3	Weight on front axle (Unladen) / rear axle (Unladen)		1580 kg / 2295 kg
Wheels			
3.1	Tires type		Solid tires
3.2	Dimensions of front wheels		23x9-10-18PR
3.3	Dimensions of rear wheels		18x7-8-14PR
3.5	Number of front wheels / rear wheels		2 / 2
3.5.2	Number of drive wheels		2
3.6	Front wheel gauge	b10	1046 mm
3.7	Rear wheel gauge	b11	960 mm
Dimensions			
4.7	Height of overhead guard (cabin)	h6	2186 mm
4.8	Seat height/stand height	h7	1155 mm
4.12	Height of towing bar (coupling height)	h10	440 mm
4.19	Overall length	l1	3357 mm
4.20	Length to face of forks	l2	2287 mm
4.21	Overall width	b1	1271 mm
4.22.1	Forks width / length	e / l	40 mm x 122 mm
4.23	Fork carriage ISO 2328 (class/form) A/B		2A
4.24	Fork carriage width	b3	1038 mm
4.31	Ground clearance below mast	m1	120 mm
4.32	Ground clearance at centre of wheelbase	m2	115 mm
4.33	Aisle Width for pallets 1000 x 1200 crossways	Ast	3670 mm
4.34	Aisle width for 800 x 1200 pallet lengthways	Ast	3866 mm
4.35	Turning radius	Wa	2035 mm
Performances			
5.1	Travel speed (laden / unladen)		19 km/h-20 km/h
5.2	Lifting speed (laden / unladen)		0.50 m/s-0.60 m/s
5.3	Lowering speed (laden / unladen)		0.51 m/s-0.54 m/s
5.5	Drawbar pull (Laden / Unladen)		8000 daN / 9000 daN
5.7	Gradeability (laden / unladen)		13 % / 24 %
5.10	Service brake		Hydraulic
Engine			
6.1	Drive motor rating S2 60 min		20 kW
6.2	Lift motor rating at S3 15%		26 kW
6.3	Battery according to DIN 43531/35/36 A, B, C		No
6.4	Battery voltage / capacity		76.80 V / 304 Ah
6.5	Battery weight (+/- 5%)		225 kg
6.6	Energy consumption according to VDI cycle (kWh/h)		6.52 kWh/h
Miscellaneous			
8.2	Working hydraulic pressure for attachments		160 bar
8.3	Oil flow rate for attachments		25 l/min
8.4	Sound level at the driver's ear according to DIN 12 053		70 dB

ME 425 LIFT - Disegno quotato

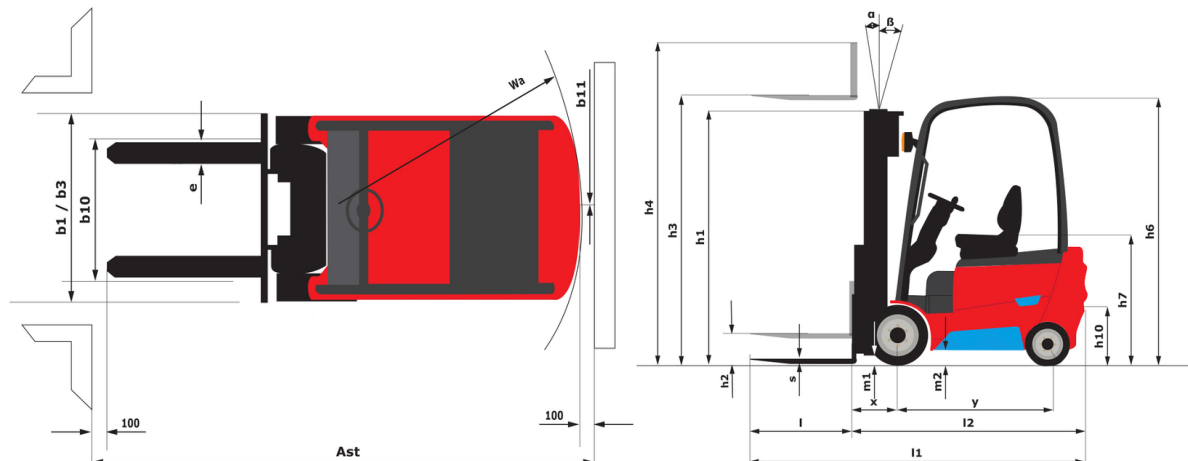

Caratteristiche dei montanti e capacità residue

Full Visibility Duplex (FVD)		FVD 30	FVD 33	FVD 37	FVD 40	FVD 45
α - Mast/fork carriage tilt, forward	°	6	6	6	6	6
β - Mast/fork carriage tilt, backward	°	12	12	12	12	6
h1 - Mast lowered height	mm	2000	2150	2400	2600	2850
h2 - Mast free lift	mm	140	140	140	140	140
h3 - Mast lifting height	mm	3000	3300	3700	4000	4500
h4 - Mast extended height	mm	4046	4346	4746	5046	5546
Residual capacity at max height	kg	2500	2500	2500	2500	2450
Residual capacity with integrated side shift at max height	kg	2450	2450	2450	2450	2400

Free Lift Triplex (FLT)		FLT 40	FLT 45	FLT 48	FLT 50	FLT 55	FLT 60	FLT 65
α - Mast/fork carriage tilt, forward	°	6	6	6	6	3	3	3
β - Mast/fork carriage tilt, backward	°	6	6	6	6	6	6	6
h1 - Mast lowered height	mm	1950	2100	2200	2300	2450	2650	2850
h2 - Mast free lift	mm	904	1054	1154	1254	1404	1604	1804
h3 - Mast lifting height	mm	4000	4500	4800	5000	5500	6000	6500
h4 - Mast extended height	mm	5046	5546	5846	6046	6546	7046	7546
Residual capacity at max height	kg	2500	2350	2250	2150	2050	1850	1600
Residual capacity with integrated side shift at max height	kg	2450	2300	2200	2100	2000	1800	1550



Sede centrale

MANITOU ITALIA Srl

Via Cristoforo Colombo 2, Loc. Cavazzona - 41013 CASTELFRANCO EMILIA (MO)

Tel: 059.95.98.11 - Fax 059.95.98.65

www.manitou.com



Questa pubblicazione presenta la descrizione delle versioni e delle possibilità di configurazione dei prodotti Manitou, che possono differire per attrezzature. Gli allestimenti presentati nel presente opuscolo possono essere di serie, optional o non disponibili, a seconda delle versioni. Manitou si riserva il diritto di modificare, in qualsiasi momento e senza alcun preavviso, le specifiche tecniche descritte e rappresentate. Le specifiche indicate non rappresentano alcun obbligo per il costruttore. Per maggiori dettagli, rivolgersi al proprio concessionario Manitou. Documento non contrattuale. Elenco delle specifiche non esaustivo. I loghi nonché l'identità visiva dell'azienda sono di proprietà di Manitou e non possono essere utilizzati senza autorizzazione. Tutti i diritti riservati. Le immagini e gli schemi contenuti nel presente opuscolo sono forniti esclusivamente a fini di consultazione e a titolo indicativo.

Manitou BF SA - Società anonima con consiglio di amministrazione. Capitale sociale: 39,668,399 euro - 857 802 508 RCS Nantes