

Technical sheet :

MT 1440 E

OXYGEN



 **MANITOU**
HANDLING YOUR WORLD

Capacities		Metric
Max. capacity	Q	4000 kg
Max. lifting height		13.55 m
Maximum outreach		9.45 m
Weight and dimensions		
Overall length to carriage	l11	6.07 m
Overall width	b1	2.36 m
Overall height	h17	2.49 m
Wheelbase	y	3.07 m
Ground clearance	m4	0.37 m
Overall cab width	b4	0.95 m
Tilt-up angle	a4	16 °
Tilt-down angle	a5	110 °
External turning radius (over tyres)	Wa1	4.01 m
Overall weight		11000 kg
Tires type		Inflatable
Standard tires		ALLIANCE - A325 - 400 / 80-24 162A8
Forks length / width / section	l / e / s	1200 mm x 125 mm x 50 mm
Performances		
Lifting		16 s
Lowering		12.40 s
Extension		17.30 s
Retraction		13 s
Crowd		4 s
Dump		4 s
Engine/Battery		
Drive motor power rating		56 kW
Hydraulic motor power		28 kW
Battery technology		Lithium-ion
Battery capacity		683 Ah
Battery nominal voltage		90 V
Battery energy		63 kWh
Charger Power / Phase / Current type		9 kW / Single-phase or three-phase / AC
Electric circuit		
Battery voltage / capacity		100 V / 683 Ah
12V Battery capacity		110 Ah
Transmission		
Transmission type		Electrical
Number of gears (forward / reverse)		2 / 2
Max. travel speed		24.90 km/h
Parking brake		Automatic parking brake
Service brake		Hydraulic
Hydraulics		
Hydraulic pump type		Variable displacement pump
Capacity of hydraulic pump		63 cm³
Hydraulic flow / Pressure		160 l/min-240 bar
Tank capacities		
Hydraulic tank capacity		135 l
Noise and vibration		
Noise at driving position (LpA)		60 dB
Noise to environment (LwA)		98 dB
Vibration on hands/arms		< 2.50 m/s²
Miscellaneous		
Steering wheels (front / rear)		2 / 2
Drive wheels (front / rear)		2 / 2
Cab certification		Cabin ROPS - FOPS level 2
Controls		JSM

Options / Finishing

S : Standard / O : Optional / - : Not available

	Standard	Comfort
Lifting function		
Attachment hydraulic line	0	S
Easy Connect System (ECS)	0	0
Operator station		
Additional handle in the cab right hand side	0	0
Adjustable and telescopic steering column	0	S
Air suspension cloth-covered seat	0	0
Bluetooth USB radio - With extra microphone - 100W	0	0
Bluetooth USB radio - With integrated microphone - 100W	0	0
Boom suspension "Active CRC"	0	0
Electric windows	0	0
Fixed armrest	0	0
Floor mat	0	S
Inner rear view mirror	0	0
Lateral wiper	0	S
Manual air conditioning	0	0
Mechanical cloth seat	0	0
Mechanical suspension PVC seat - Grammer MSG65	S	S
Radio pre-fitting	0	S
Rear camera with cab display screen	0	0
Tuner car radio - 50W	0	0
Motorization/Power		
Centralized greasing points	0	0
Continuous flow hydraulics	0	0
Europe plug adapter - Three-phase cable	S	S
On-board charger 9kW	S	S
Plug for MANITOU external charger - 30kW DC - Lithium-ion	S	-
Three-phase charging cable kit + adapters	S	S
Lighting		
LED front road lights	-	S
LED front work lights	0	0
LED rear work lights	0	0
LED work lights - On boom head (Telescopic part)	0	0
Security		
Battery cut-off	S	S
Emergency stop button outside the cab	0	0
OSS - Operation Safety System	0	0
Pedestrian detection camera (rear)	0	0
Pneumatics		
Tires - ALLIANCE - A325 - 400/80-24 162A8	S	S
Tires - ALLIANCE - A325 - 440/80 R24 162A8	0	0
Tires - MICHELIN - BIBLOAD - 440/80 R24 161A8	0	0

MT 1440 e - Dimensional drawing

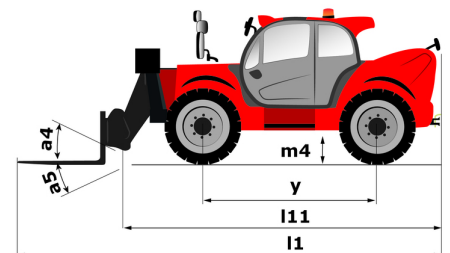

MT 1440 e - Load chart

Machine on tires with forks Metric

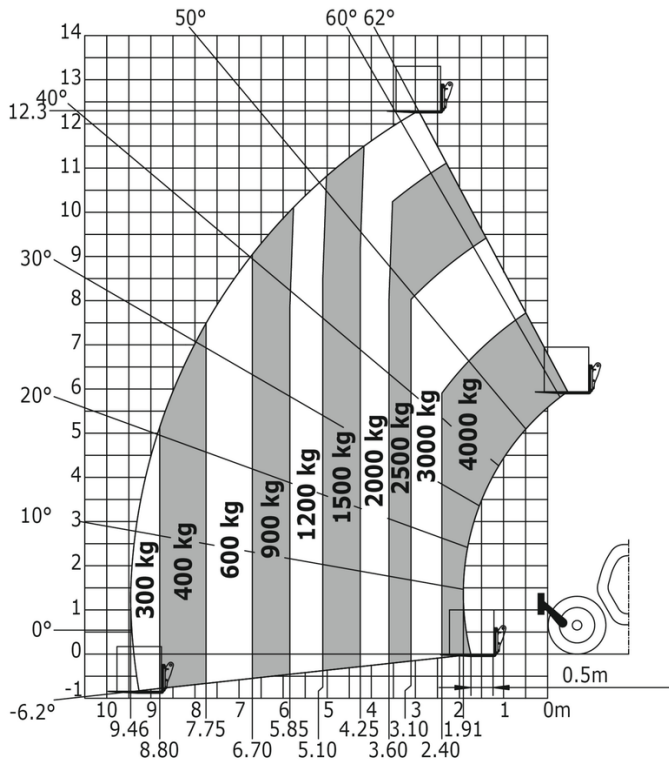

Machine on lowered stabilisers with forks Metric

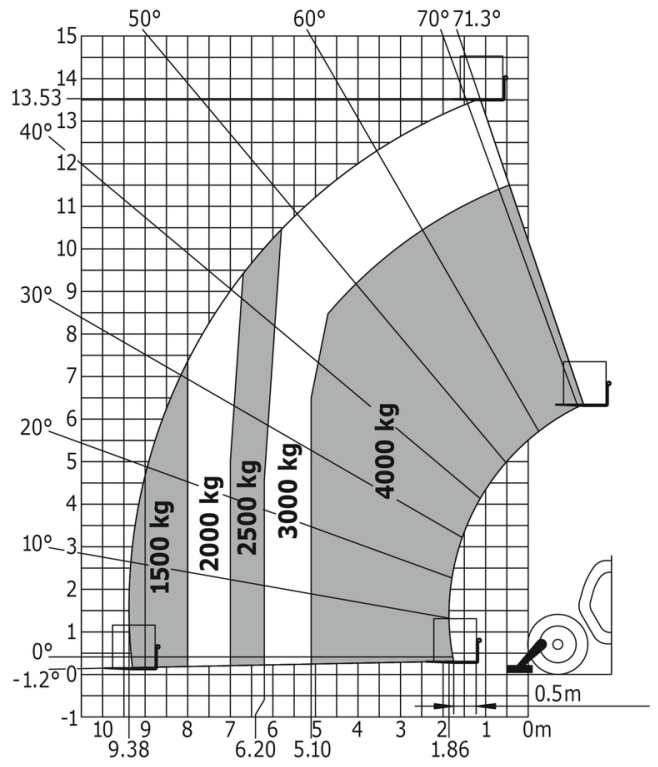



Head Office

B.P. 249 - 430 rue de l'Aubinière
44150 Ancenis Cedex - France

Tel: +33 (0)2 40 09 10 11 - Fax: +33 (0)2 40 09 10 97

www.manitou.com



This publication provides a description of the configuration versions and options for Manitou products, which may differ for equipment. The equipment presented in this brochure may be part of a series, as an option, or it may not be available, depending on the versions. Manitou reserves the right, at any time and without notice, to amend the specifications described and represented. The specifications provided do not bind the manufacturer. For more details, please contact your Manitou agent. This is not a contractually binding document. The presentation of the products is not contractually binding. List of specifications non-exhaustive. The logos as well as the visual identity of the company are owned by Manitou and cannot be used without authorisation. All rights reserved. The photos and diagrams contained in this brochure are only provided for consultation and information purposes.

MANITOU BF SA - Limited company with board of directors - Share capital: 39,668,399 euros - 857 802 508 RCS Nantes