

Technical sheet :

MLT 742-130 PS+ (S1)



 **MANITOU**
HANDLING YOUR WORLD

Capacities		Metric
Max. capacity	Q	4200 kg
Max. lifting height		6.91 m
Maximum outreach		3.96 m
Reach at max. height		1 m
Breakout force with bucket		5748 daN
Weight and dimensions		
Unladen weight (with forks)		8120 kg
Ground clearance	m4	0.41 m
Wheelbase	y	2.81 m
Overall length to carriage (with hitch)	l11	5.02 m
Front overhang		1.26 m
Overall width	b1	2.39 m
Overall cab width	b4	0.95 m
Overall height	h17	2.38 m
Tilt-down angle	a5	133 °
Tilt-up angle	a4	14 °
External turning radius (over tyres)	Wa1	3.93 m
Standard tires		Alliance - A580 - 460/70 R24 159A8
Drive wheels (front / rear)		2 / 2
Steering mode		Manicrab, 2 wheel steer, 4 wheel steer, Crab mode
Performances		
Lifting		8.70 s
Lowering		8.60 s
Extension		6.90 s
Retraction		6.10 s
Crowd		3.60 s
Dump		3.10 s
Engine		
Engine brand		Deutz
Engine norm		Stage V
Engine model		TCD 3.6 L4
Number of cylinders - Capacity of cylinders		4 - 3621 cm ³
Engine power (Hp / kW)		129 Hp / 95 kW
Max. torque / Engine rotation		500 Nm @1600 rpm
Drawbar pull (Laden)		8000 daN
Reversible fan		Standard
Engine cooling system		4 radiators (water + intercooler + hydraulic oil + transmission oil)
HVO validated (according to EN 15940 standard)		Yes
Transmission		
Transmission type		Torque converter
Gearbox		Powershift
Number of gears (forward / reverse)		6 / 3
Max. travel speed (may vary according to applicable regulations)		40 km/h
Differential lock		Limited slip differential on front axle
Parking brake		Automatic negative parking brake
Service brake		Oil-immersed multi-discs braking on front & rear axles
Hydraulics		
Hydraulic pump type		Variable displacement pump
Hydraulic flow - Pressure		150 l/min - 270 bar
Flow sharing distributor		Standard
Tank capacities		
Hydraulic tank capacity		135 l
Fuel		120 l
Diesel Exhaust fluid (AdBlue® type)		10 l
Noise and vibration		
Noise at driving position (LpA) tested following NF EN 12053 norm		72 dB
Vibration on hands/arms		< 2.50 m/s ²
Miscellaneous		
Tractor homologation		Tractor homologation
Cab certification		Cabin ROPS - FOPS level 2
Controls		JSM

Optional tires tab

	Overall height	Overall width
ALLIANCE - A585 - 460/70 R24 159A8	2.37 m	2.40 m
NOKIAN - TRI STEEL - 460/65 R24 156A8	2.36 m	2.40 m
MICHELIN - BIBLOAD - 460/70 R24 159A8	2.37 m	2.40 m
MICHELIN - BIBLOAD - 500/70 R24 164A8	2.39 m	2.43 m
MICHELIN - XHA - 15.5 R25 158A2	2.37 m	2.40 m
MICHELIN - XMCL - 460/70 R24 159A8	2.37 m	2.40 m
MICHELIN - XMCL - 500/70 R24 164A8	2.39 m	2.43 m
TRELLEBORG - TH400 - 460/70 R24 159A8	2.37 m	2.40 m
TRELLEBORG - TH400 - 500/70 R24 164A8	2.39 m	2.42 m
VREDESTEIN - ENDURION - 460/70 R24 159A8	2.38 m	2.41 m
VREDESTEIN - ENDURION - 500/70 R24 164A8	2.41 m	2.44 m

Options / Finishing

S : Standard / 0 : Optional / - : Not available

	Classic	Premium	Elite	Platinum
Lifting function				
Attachment hydraulic locking	0	0	0	S
Intelligent hydraulics	0	0	0	S
Regenerative Hydraulics	0	0	0	S
Operator station				
Additional front wiper - Without washer	0	S	S	S
Air suspension fabric seat - GRAMMER	0	S	-	-
Automatic wheel alignment	0	0	S	S
Bluetooth USB radio - With extra microphone - 100W	0	0	S	S
Bluetooth USB radio - With integrated microphone - 100W	0	S	-	-
Boom suspension "Active CRC"	0	0	S	S
Enclosed cab + Heater and automatic air conditioning	0	S	S	S
Exterior right electric rear-view mirror with defroster	0	0	S	S
HighView camera on boom head (Telescopic part)	0	0	0	S
Lateral wiper	S	S	S	S
Low frequency air suspension fabric seat - GRAMMER	0	0	S	-
Low frequency air suspension heated fabric seat - GRAMMER	0	0	0	S
Mechanical suspension fabric seat - GRAMMER	S	-	-	-
Right hand side and rear SafeView cameras	0	0	0	S
Storage box - On the shelf	0	0	0	S
Tuner car radio - 50W	S	-	-	-
Vision screen - 7 in.	S	S	S	S
Motorization/Power				
Auto reversing fan	S	S	S	S
Continuous flow hydraulics	0	0	S	S
Hand throttle	0	0	S	S
Secondary functions				
Automatic greasing system (AGS) - Chassis + boom	0	0	0	S
Lighting				
LED front road lights	0	0	0	S
LED side work lights	0	0	0	S
LED work lights - On boom head (Telescopic part)	0	0	0	S

MLT 742-130 PS+ (S1) - Dimensional drawing

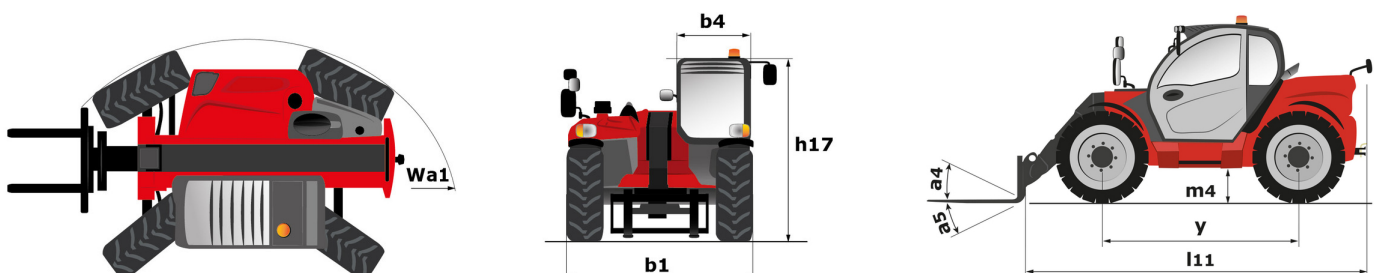

MLT 742-130 PS+ (S1) - Load chart

Machine on tires with forks Metric





Head Office

B.P. 249 - 430 rue de l'Aubinière
44150 Ancenis Cedex - France

Tel: +33 (0)2 40 09 10 11 - Fax: +33 (0)2 40 09 10 97

www.manitou.com



This publication provides a description of the configuration versions and options for Manitou products, which may differ for equipment. The equipment presented in this brochure may be part of a series, as an option, or it may not be available, depending on the versions. Manitou reserves the right, at any time and without notice, to amend the specifications described and represented. The specifications provided do not bind the manufacturer. For more details, please contact your Manitou agent. This is not a contractually binding document. The presentation of the products is not contractually binding. List of specifications non-exhaustive. The logos as well as the visual identity of the company are owned by Manitou and cannot be used without authorisation. All rights reserved. The photos and diagrams contained in this brochure are only provided for consultation and information purposes.

MANITOU BF SA - Limited company with board of directors - Share capital: 39,668,399 euros - 857 802 508 RCS Nantes