

Technical sheet :

# MLT 625 E

OXYGEN



 **MANITOU**  
HANDLING YOUR WORLD

Capacities		Metric
Max. capacity	Q	2500 kg
Max. lifting height		5.90 m
Maximum outreach		3.30 m
Reach at max. height		0.50 m
Breakout force with bucket		3770 daN
Weight and dimensions		
Unladen weight (with forks)		4762 kg
Ground clearance	m4	0.38 m
Wheelbase	y	2.30 m
Overall length to carriage (with hitch)	l11	3.90 m
Overall length to carriage (without hitch)	l3	3.90 m
Overall width	b1	1.81 m
Overall cab width	b4	0.80 m
Overall height	h17	2 m
Tilt-down angle	a5	117 °
Tilt-up angle	a4	12 °
External turning radius (over tyres)	Wa1	3.31 m
Standard tires		Alliance - A580 - 300/75 R18 142A8
Steering mode		Manicrab, 2 wheel steer, 4 wheel steer, Crab mode
Performances		
Lifting		11.10 s
Lowering		8 s
Extension		7.70 s
Retraction		7.40 s
Crowd		4.45 s
Dump		4.30 s
Engine/Battery		
Battery technology		Lithium-ion
Battery capacity		348 Ah
Battery energy		34.80 kWh
Drive motor power rating		40 kW
Hydraulic motor power		30 kW
Charger Power		9 kW
Electric circuit		
Battery nominal voltage		100 V
12V Battery capacity		74 Ah
Transmission		
Transmission type		Electrical
Number of gears (forward / reverse)		1 / 1
Max. travel speed (may vary according to applicable regulations)		20 km/h
Differential lock		Limited slip differential on front axle
Parking brake		Automatic negative parking brake
Service brake		Oil-Immersed multi-discs braking on front axles
Hydraulics		
Hydraulic pump type		Gear pump
Hydraulic flow - Pressure		84 l/min - 235 bar
Flow sharing distributor		Standard
Tank capacities		
Hydraulic tank capacity		80 l
Noise and vibration		
Noise at driving position (LpA) tested following NF EN 12053 nom		72 dB
Noise to environment (LwA)		92 dB
Vibration on hands/arms		< 2.50 m/s <sup>2</sup>
Miscellaneous		
Cab certification		ROPS - FOPS cab (level 1)
Controls		JSM

## Optional tires tab

	Overall height	Overall width
MICHELIN - BIBSTEEL ALL TERRAIN - 300/70 R16.5 141A5	1.97 m	1.81 m
CAMSO - SKS532 - 12-16.5 145A2	1.92 m	1.81 m
CAMSO - SKS732 - 12-16.5 145A2	1.92 m	1.81 m

## MLT 625 e - Dimensional drawing



## MLT 625 e - Load chart

Machine on tires with forks Metric



Machine on tires with forks LC 600 mm Metric

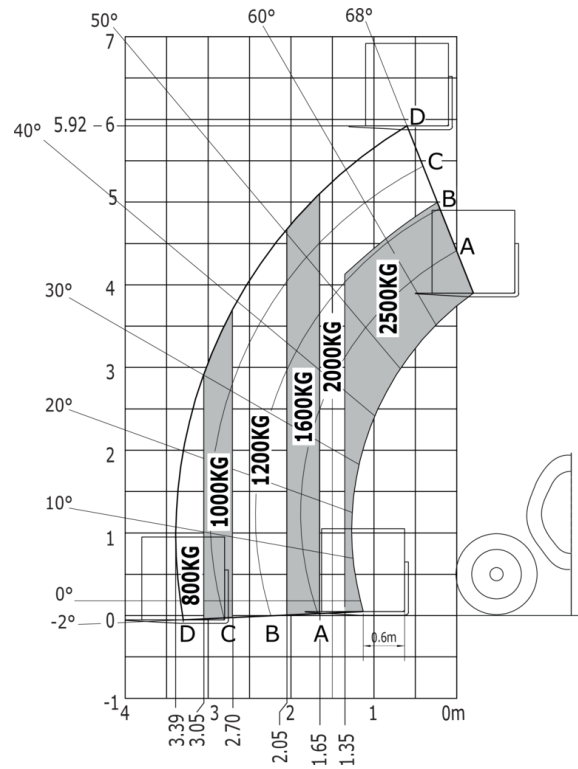



**Head Office**

B.P. 249 - 430 rue de l'Aubinière  
44150 Ancenis Cedex - France

Tel: +33 (0)2 40 09 10 11 - Fax: +33 (0)2 40 09 10 97

[www.manitou.com](http://www.manitou.com)



This publication provides a description of the configuration versions and options for Manitou products, which may differ for equipment. The equipment presented in this brochure may be part of a series, as an option, or it may not be available, depending on the versions. Manitou reserves the right, at any time and without notice, to amend the specifications described and represented. The specifications provided do not bind the manufacturer. For more details, please contact your Manitou agent. This is not a contractually binding document. The presentation of the products is not contractually binding. List of specifications non-exhaustive. The logos as well as the visual identity of the company are owned by Manitou and cannot be used without authorisation. All rights reserved. The photos and diagrams contained in this brochure are only provided for consultation and information purposes.

MANITOU BF SA - Limited company with board of directors - Share capital: 39,668,399 euros - 857 802 508 RCS Nantes