

Fiche technique :

MRT 2260 E

OXYGEN



 **MANITOU**
HANDLING YOUR WORLD

Capacités		Métrique
Capacité max.		6000 kg
Hauteur de levage max.		21.80 m
Déport max.		18.20 m
Poids et dimensions		
Longueur hors-tout (avec fourches)	l1	8.17 m
Longueur au talon des fourches	l2	6.97 m
Largeur hors tout	b1	2.50 m
Hauteur hors tout	h17	3.10 m
Largeur hors tout cabine	b4	0.96 m
Garde au sol	m4	0.38 m
Empattement	y	3.05 m
Angle de cavage	a4	12 °
Angle de déversement	a5	110 °
Rotation tourelle		360 °
Poids		18000 kg
Longueur de fourches / Largeur de fourches / Section de fourches	l / e / s	100 mm x 1200 mm x 60 mm
Roues		
Pneus standards		445/65 R22,5
Roues motrices (avant / arrière)		2 / 2
Mode de direction		2 roues directrices, 4 roues directrices, Mode crabe
Stabilisateurs		
Type de stabilisateurs		Télescopique duplex
Commandes avec stabilisateurs		Stabilisateurs à commande individuelle ou simultanée
Circuit électrique		
Nombre de batterie / Tension batterie		2 x 12 V
Capacité batterie 12V		120 Ah
Courant de démarrage des batteries		(EN)850 A
Moteur/batterie		
Technologie batterie		Lithium-ion
Capacité de la batterie		105 Ah
Tension nominale batterie		624 V
Tension max. batterie		680 V
Énergie batterie		65 kWh
Puissance du moteur électrique		107 kW
Puissance moteur hydraulique		84 kW
Puissance du chargeur / Phase / Type de courant		11 kW / Monophasé ou triphasé / AC
Transmission		
Type de transmission		Électrique
Nombre de vitesses (avant / arrière)		2 / 2
Vitesse de déplacement max.		37 km/h
Effort de traction		8600 daN
Force de traction continue		4300 daN
Frein de parking		Frein de stationnement négatif automatique
Frein de service		Freinage multidisques à bain d'huile sur pont avant et arrière
Performances		
Pente franchissable maximale - en charge / à vide		36 % / 48 %
Pente franchissable continue (en charge / à vide)		18 % / 23 %
Hydraulique		
Type de pompe hydraulique		Piston à déplacement fixe
Débit hydraulique		175 l/min
Pression hydraulique		350 bar
Capacité du réservoir hydraulique		200 l
Bruit et vibration		
Bruit au poste de conduite (LpA)		65 dB
Bruit à l'environnement (LWA)		103 dB
Vibration sur l'ensemble mains/bras		< 2.50 m/s ²
Divers		
Roues directrices (avant / arrière)		2 / 2
Commandes		2 Joysticks
Certification cabine		Cabine ROPS - FOPS niveau 2
Système de reconnaissance automatique des accessoires (E-Reco)		Standard

MRT 2260 e - Schémas d'encombrement



Autres données			Métrique
Longueur du châssis		l14	5.69 m
Empattement		y	3.05 m
Garde au sol		m4	0.38 m
Déport du contrepoids (toureille à 90°)		a7	2.97 m
Angle de cavage		a4	12 °
Angle de déversement		a5	110 °
Longueur hors tout aux stabilisateurs		l12	5.30 m
Rayon de braquage (extérieur roues)		Wa1	4.46 m
Largeur hors tout stabilisateurs déployés		b7	5.79 m
Hauteur hors tout		h17	3.10 m
Correcteur de dévers		a9	+/- 7 °
Garde au sol sous les pneus avant sur stabilisateurs		m5	0.43 m

MRT 2260 e - Abaques

Machine sur pneus avec fourches

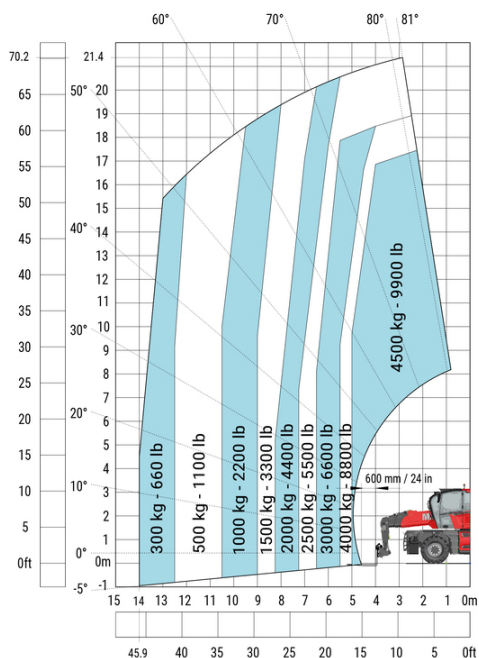

Machine sur stabilisateurs abaissés avec fourches (CAF)
Métric

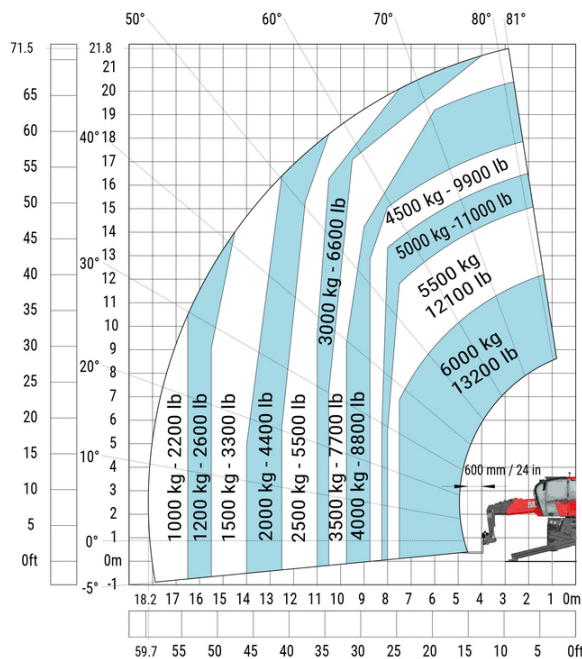

Machine sur stabilisateurs abaissés avec treuil 6000 kg (Métrique)

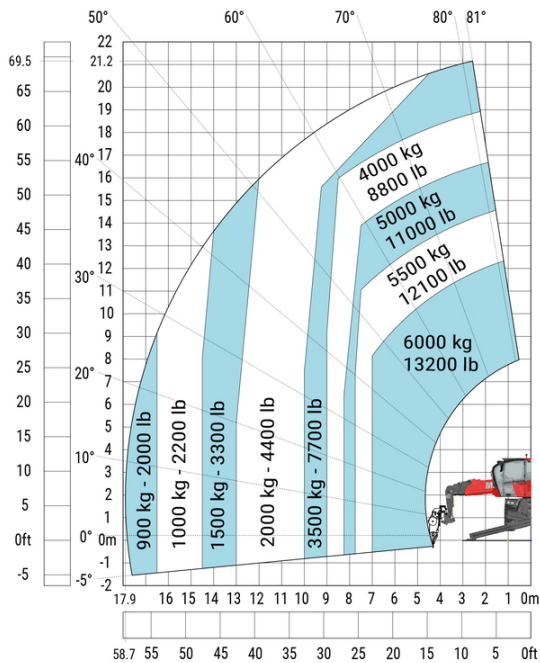

Machine sur stabilisateurs abaissés avec potence-treuil de 1500 kg (Métrique)

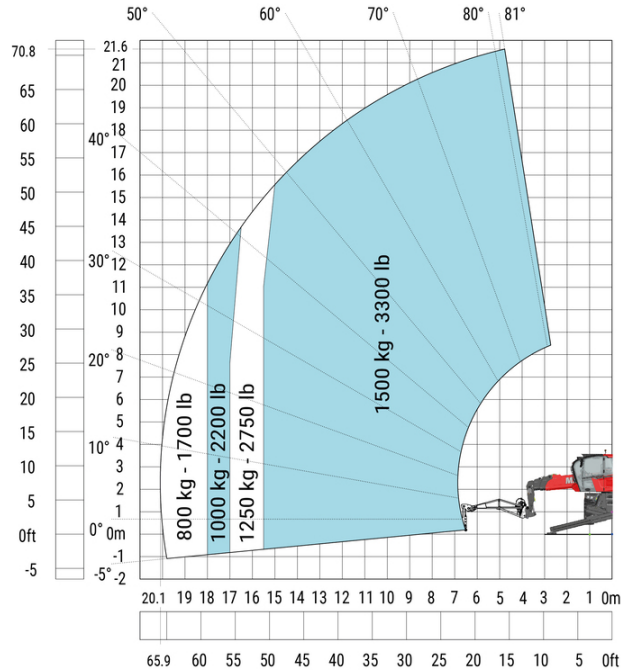

Machine sur stabilisateurs abaissés avec potence-treuil extensible (Métrique)

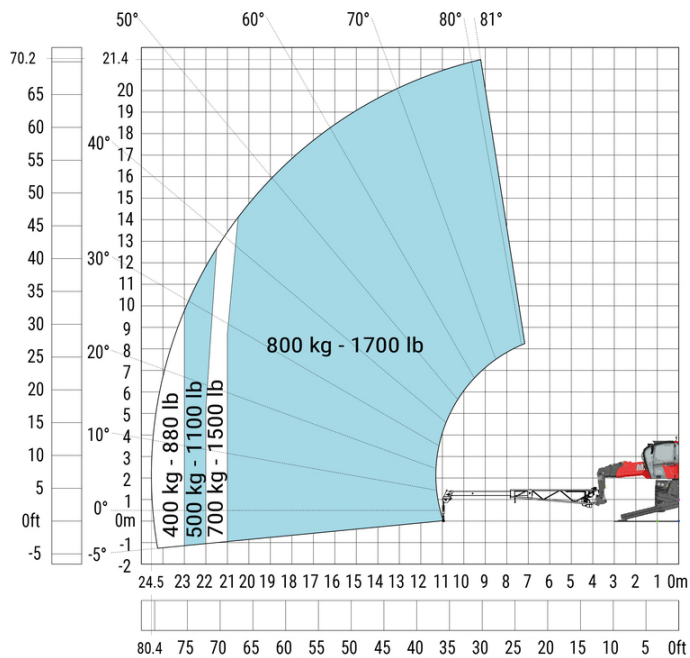

Machine sur stabilisateurs abaissés avec crochet 6000 kg (Métrique)

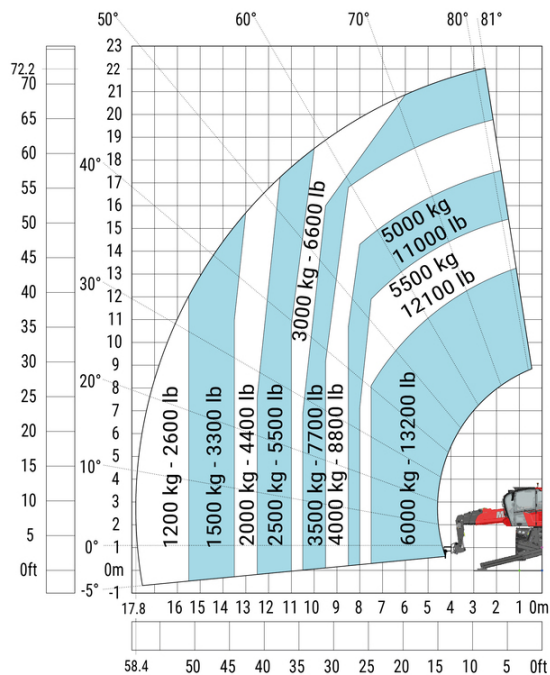

Machine sur stabilisateurs abaissés avec nacelle 365 kg

Machine sur stabilisateurs abaissés avec nacelle 1000 kg

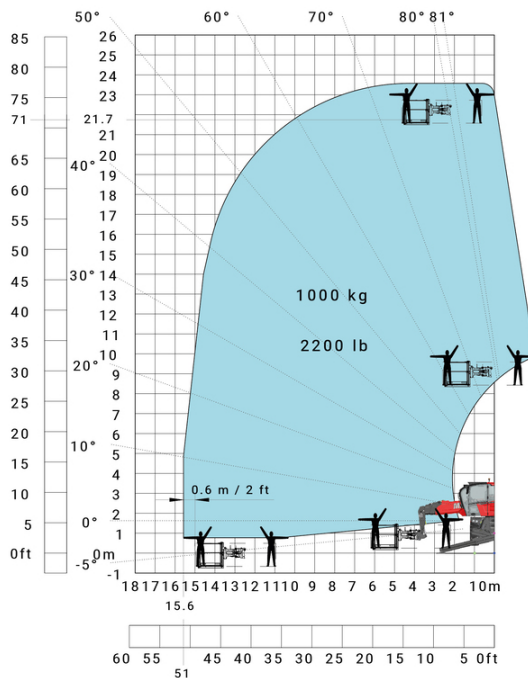
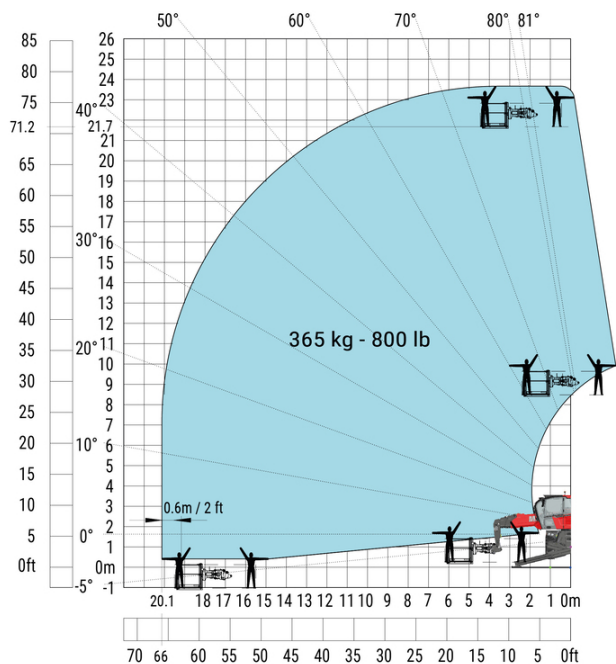

Machine sur stabilisateurs abaissés avec 3D positif

Machine sur stabilisateurs abaissés avec 3D positif / négatif

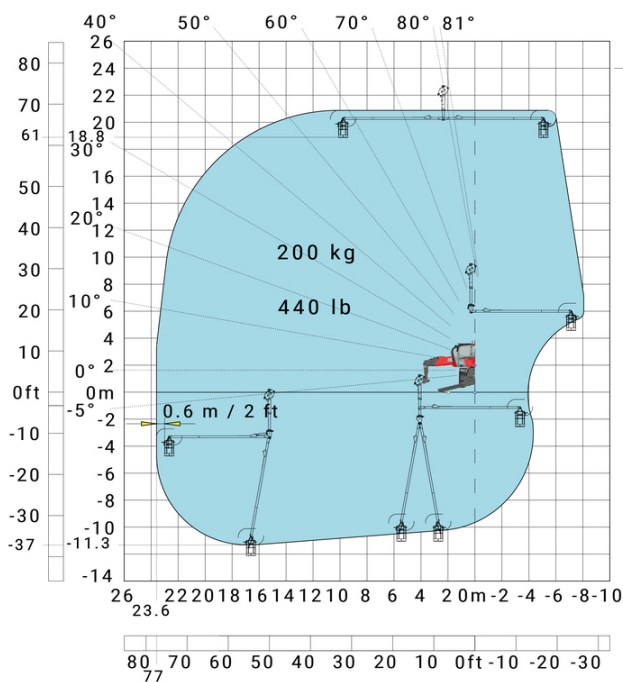
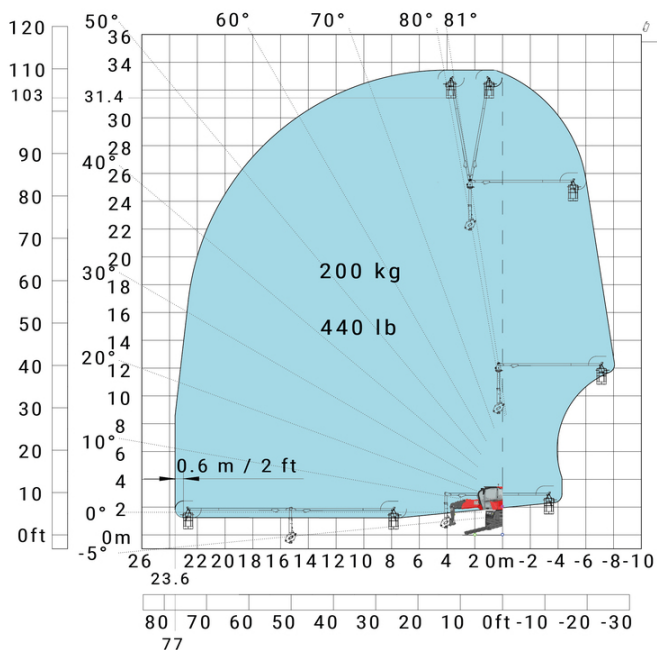

Équipements

Optionnel

- Batterie additionnelle haute tension 65 kWh
- Prolongateur d'autonomie amovible 18.4 kW

Équipement : Prolongateur d'autonomie amovible 18.4 kW

Moteur		Métrique
Marque du moteur / Norme moteur		Yanmar / Stage V / Tier 4
Modèle du moteur		3TNV80F-ZXKMU
Nombre de cylindres - Cylindrée		3 - 1267 cm ³
Couple max. / Régime moteur (min)		74.50 Nm @ 1900 tr/min
Puissance		18.40 kW
Régime moteur		2800 tr/min
Système de refroidissement		Refroidissement par eau
Puissance du moteur I.C. (ch)		25 ch
Capacités des réservoirs		
Réservoir à carburant		65 l
Huile moteur		3.40 l



 **MANITOU**
HANDLING YOUR WORLD

Siège Social

B.P. 249 - 430 rue de l'Aubinière

44150 Ancenis Cedex - France

Tel: +33 (0)2 40 09 10 11 - Fax: +33 (0)2 40 09 10 97

www.manitou.com



Cette publication présente le descriptif des versions et possibilités de configuration des produits Manitou qui peuvent différer en équipement. Les équipements présentés dans cette brochure peuvent être de série, en option, ou non disponibles suivant les versions. Manitou se réserve le droit, à tout moment et sans préavis, de modifier les spécifications décrites et représentées. Les spécifications portées n'engagent pas le constructeur. Pour plus de détails, contactez votre concessionnaire Manitou. Document non contractuel. Présentation des produits non contractuelle. Liste des spécifications non exhaustive. Les logos ainsi que l'identité visuelle de l'entreprise sont la propriété de Manitou et ne peuvent être utilisés sans autorisation. Tous droits réservés. Les photos et schémas contenus dans la présente brochure ne sont fournis qu'à des fins de consultation et à titre indicatif.

Manitou BF SA - Société anonyme à conseil d'administration - Capital social : 39 668 399 euros - 857 802 508 RCS Nantes