

Technical sheet :

V'AIR 23

OXYGEN
by MANITOU



 **MANITOU**
HANDLING YOUR WORLD

Capacities		Imperial
Working height	h21	23 ft
Platform height	h7	23 ft
Max. outreach		6 ft 8 in
Platform capacity	Q	507 lb
Turret rotation		355 °
Number of people (indoor / outdoor)		2 / 2
Weight and dimensions		
Platform weight*		5975 lb
Platform dimensions (length x width)	lp / ep	3 ft 1 in x 2 ft 3 in
Floor height (access)	h20	3 ft 5 in
Overall length	l1	7 ft 7 in
Overall width	b1	3 ft 7 in
Overall height	h17	7 ft 7 in
Counterweight offset (turret at 90°)	a7	2 in
Counterweight Oversize / Reach		2 in
External turning radius	Wa3	6 ft 6 in
Ground clearance at centre of wheelbase	m2	2 ft 11 in
Wheelbase	y	3 ft 11 in
Performances		
Drive speed - stowed		3 mph
Drive speed - raised		0.37 mph
Gradeability		25 %
Permissible leveling		2 °
Wheels		
Tires type		Non marking
Standard tires		16.5-11 1/4 / 406 x 127 mm
Drive wheels (front / rear)		0 / 2
Steering wheels (front / rear)		2 / 0
Braking wheels (front / rear)		0 / 2
Engine/Battery		
Electric engine power rating		2 x 1.50 kW
Number of hydraulic pump / Capacity of hydraulic pump		2 x 0.26 in³
Battery voltage		24 V
Battery capacity		250 Ah
On-board charger (V / A)		24 V / 30 A
Miscellaneous		
Number of cycles with STD Battery (HIRD)		39
Ground Pressure		164 PSI
Hydraulic Pressure		2031 PSI
Hydraulic tank capacity		6 US gal
Standards compliance		
This machine is in compliance with:		ANSI A92.20-2018 CSA B354.6 ICES-002-Issue 6 Standard Canadian EMC

V'Air 23 - Load chart

Load Chart for MEWP (Imperial)

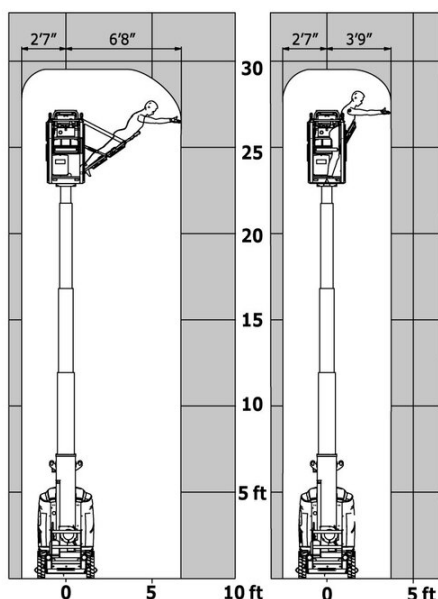

V'Air 23 - Dimensional drawing

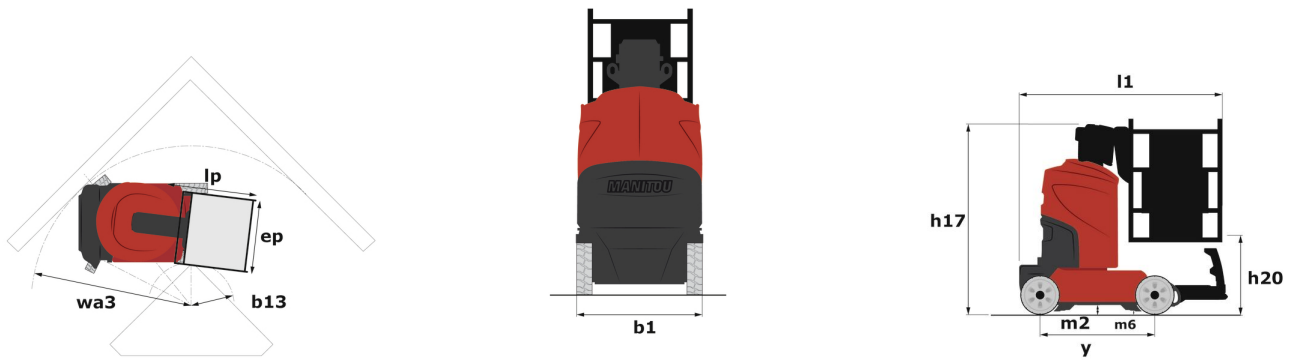

Equipment

Standard

- 2 LED front headlights with protective grille
- 2 rear position headlights with LED
- 2 vertical detection radars
- 3 anti-static braids
- Audible alarm and illuminated indicator lamp (leveling, overload, lowering)
- Backlit control panel
- Battery charge indicator lamp
- CAN bus technology
- Emergency stop button in platform and on frame
- Fixed pothole protection
- Fork pockets
- Front and side rubber protections
- Horn in the platform
- Hour meter
- Integrated diagnostic assistance
- Manual emergency lowering
- Multi-voltage integrated charger
- Negative-type braking on rear wheels
- Non-marking rubber tyres
- Platform with open-work floor
- Proportional controls
- Side reflectors
- Slings and securing rings
- Specific platform with multiple working positions
- Tool box in platform
- Traction battery with centralized recharging
- Travel possible at maximum height
- Working headlight in platform

Optional

- 6 kg Powder extinguisher A, B, C
- Biodegradable oil
- Cold weather protection oil



Head Office

B.P. 249 - 430 rue de l'Aubinière

44150 Ancenis Cedex - France

Tel: +33 (0)2 40 09 10 11 - Fax: +33 (0)2 40 09 10 97

www.manitou.com



This publication provides a description of the configuration versions and options for Manitou products, which may differ for equipment. The equipment presented in this brochure may be part of a series, as an option, or it may not be available, depending on the versions. Manitou reserves the right, at any time and without notice, to amend the specifications described and represented. The specifications provided do not bind the manufacturer. For more details, please contact your Manitou agent. This is not a contractually binding document. The presentation of the products is not contractually binding. List of specifications non-exhaustive. The logos as well as the visual identity of the company are owned by Manitou and cannot be used without authorisation. All rights reserved. The photos and diagrams contained in this brochure are only provided for consultation and information purposes.

MANITOU BF SA - Limited company with board of directors - Share capital: 39,668,399 euros - 857 802 508 RCS Nantes