

Technisches Datenblatt :

# 180 ATJ E RC

OXYGEN



 **MANITOU**  
HANDLING YOUR WORLD

Capacities		Metrisch
Working height	h21	18.19 m
Platform height	h7	16.19 m
Max. outreach		10.33 m
Overhang		7.43 m
Pendular arm rotation (left / right)		90 ° / 90 °
Pendular arm rotation (top / bottom)		+65 ° / -59.50 °
Platform capacity	Q	250 kg
Turret rotation		360 °
Platform rotation (right / left)		90 ° / 90 °
Number of people (indoor / outdoor)		2 / 2
Weight and dimensions		
Platform weight*		7550 kg
Platform dimensions (length x width)	lp / ep	1.80 m x 0.80 m
Floor height (access)	h20	0.45 m
Overall length	l1	7.61 m
Overall width	b1	2.32 m
Overall height	h17	2.48 m
Overall length (stowed)	l9	5.43 m
Overall height (stowed)	h18 ***	2.52 m
Counterweight offset (turret at 90°)	a7	0.40 m
Counterweight Oversize / Reach		0.40 m
External turning radius	Wa3	3.75 m
Ground clearance at centre of wheelbase	m2	0.40 m
Wheelbase	y	2.30 m
Performances		
Drive speed - stowed		5 km/h
Drive speed - raised		1 km/h
Gradeability		45 %
Permissible leveling		5 °
Wheels		
Tires type		Foam Filled Non Marking
Standard tires		914 x 381 mm / 36X15D610
Drive wheels (front / rear)		2 / 2
Steering wheels (front / rear)		2 / 2
Braking wheels (front / rear)		0 / 2
Engine/Battery		
Battery voltage		48 V
Battery nominal voltage / capacity		48 V / 480 Ah
Battery energy		23 kWh
On-board charger (V / A)		48 V / 60 A
Miscellaneous		
Ground Pressure		10 dan/cm2
Hydraulic Pressure		240 bar
Hydraulic tank capacity		24 l
Noise to environment (LWA)		< 98 dB
Standards compliance		
This machine is in compliance with:		European directives: 2006/42/EC- Machinery (revised EN280:2013) - 2004/108/EC (EMC) - 2006/95/EC (Low voltage)

\*Varies according to options and standards of the country to which the machine is delivered

\*\* According to "REDUCE cycle"

# 180 ATJ e RC - Traglasttabellen

Load Chart for MEWP Metric



# 180 ATJ e RC - Maßzeichnung

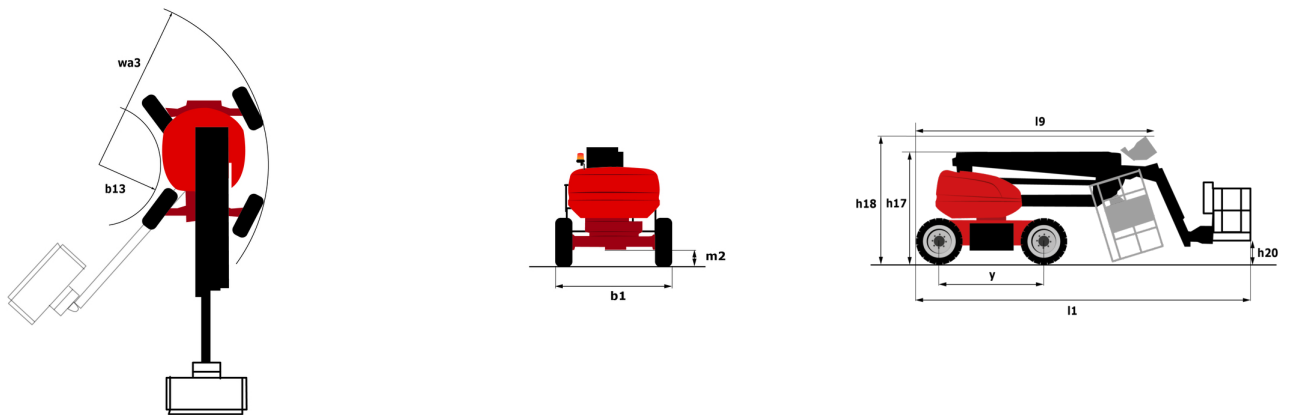

# Ausstattung

## Standard

220V predisposition in the platform  
 4 simultaneous movements  
 4 wheel drive  
 4 wheel steer with crab mode  
 Audible alarm and illuminated indicator lamp (leveling, overload, lowering)  
 Backup electrical pump  
 CAN bus technology  
 Continuous turret rotation  
 Differential locking on rear axle  
 Easy Link with 2 year Service  
 Easy Manager  
 Emergency stop button in platform and on frame  
 Fully galvanized basket with demountable floor  
 Galvanized basket 1,800 mm  
 Hom in the platform  
 Hour meter  
 LED rotating beacon  
 Large color screen on turret  
 Leveling unlocking  
 Load sensing pump  
 Operator presence pedal  
 Oscillating front axle  
 Rear axle with limited slip differential  
 Reserve mode  
 Screen information in the basket  
 Secondary Protection System (SPS)  
 Secondary Protection System (SPS) - With LED red strobe lights  
 Simplified lifting system without spreader bar  
 Slings and securing rings  
 Steer and rotate  
 Turret orientation information

## Optional

110 V electric plug 16A  
 Audio warning on all motion  
 Audio warning on all motion - White noise  
 Audio warning on movement  
 Audio warning on translation - White noise  
 Biodegradable hydraulic oil - Grade 32  
 Biodegradable oil  
 Bottom screen protection  
 Continuous turret rotation  
 Digicode anti-theft device  
 Earthing and shortcircuiting pre-fitting (Bolted ball)  
 Easy Link - With access control keypad  
 Easy link with remote lock  
 Electric centralized filling  
 External pneumatic supply source  
 Foam-filled tires 914 x 381 mm / 36X15D610  
 Fully galvanized basket 1800mm / 5'11" with lateral door  
 Galvanized basket 2,100 mm  
 Galvanized basket 2.100 mm / 6'11" with lateral door  
 Hydraulic oil heater  
 Key lock on turret cover  
 Lighting pack  
 Locking the telescope by parameter setting  
 OSS - Operation Safety System  
 Packing for containerization  
 Personalized paintwork  
 Rail protection  
 Safety kit - Harness + helmet  
 Socket 230 V + differential circuit breaker  
 Two safety kits (helmet + harness)  
 Water heater  
 Water predisposition  
 Working light (x1) on basket



**Hauptsitz**

B.P. 249 - 430 rue de l'Aubinière

44150 Ancenis Cedex - France

Tel: +33 (0)2 40 09 10 11 - Fax: +33 (0)2 40 09 10 97

[www.manitou.com](http://www.manitou.com)



Diese Publikation enthält eine Beschreibung der Konfigurationsvarianten und Optionen für Manitou-Produkte, die je nach Ausstattung unterschiedlich sein können. Die in dieser Broschüre vorgestellten Ausstattungen können Teil einer Serie, als Option erhältlich oder je nach Ausführung nicht verfügbar sein. Manitou behält sich das Recht vor, die beschriebenen und dargestellten Spezifikationen jederzeit und ohne Vorankündigung zu ändern. Die angegebenen Spezifikationen sind für den Hersteller nicht bindend. Für weitere Einzelheiten wenden Sie sich bitte an Ihren Manitou-Händler. Es handelt sich nicht um ein vertraglich bindendes Dokument. Die Darstellung der Produkte ist vertraglich nicht bindend. Die Liste der Spezifikationen ist nicht vollständig. Die Logos sowie die visuelle Identität des Unternehmens sind Eigentum von Manitou und dürfen nicht ohne Genehmigung verwendet werden. Alle Rechte vorbehalten. Die in dieser Broschüre enthaltenen Fotos und Diagramme werden nur zu Anschauungs- und Informationszwecken zur Verfügung gestellt.

MANITOU BF SA - Gesellschaft mit beschränkter Haftung mit Verwaltungsrat - Aktienkapital: 39 668 399 Euro - 857 802 508 RCS Nantes