

Fiche technique :

180 ATJ E RC

OXYGEN

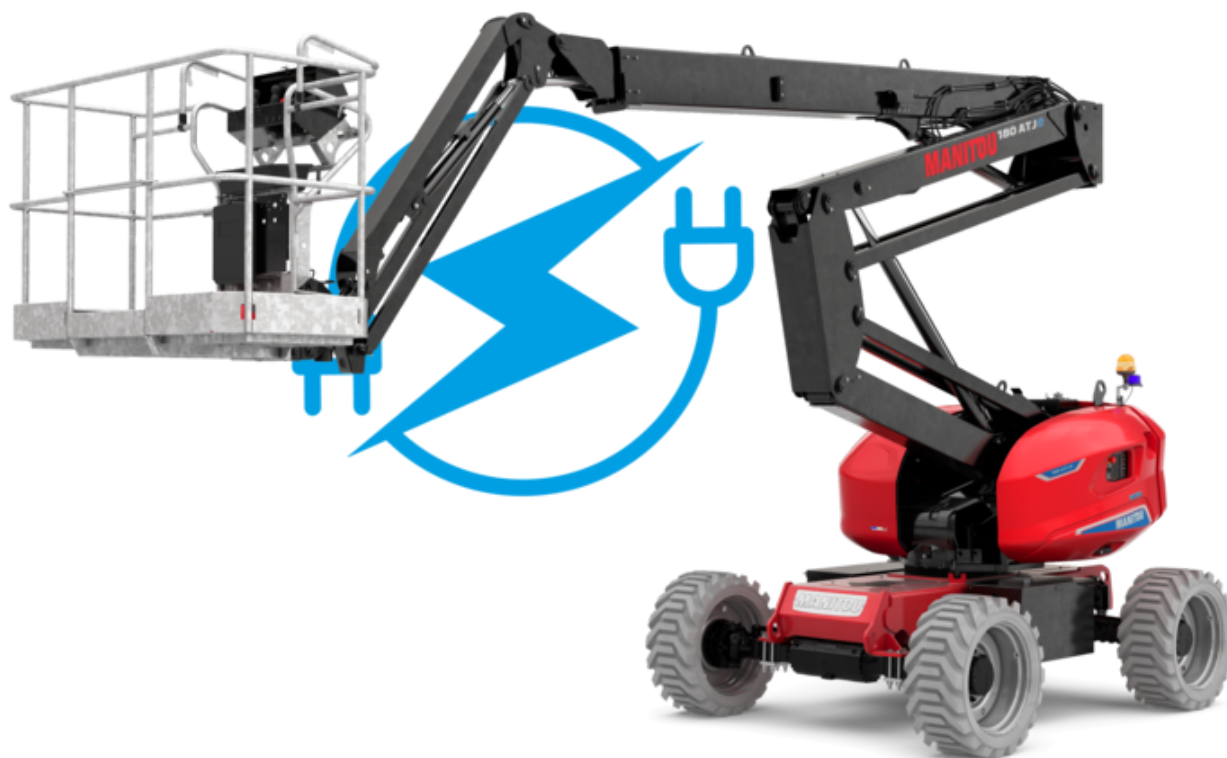

 **MANITOU**
HANDLING YOUR WORLD

Capacities		Métrique
Working height	h21	18.19 m
Platform height	h7	16.19 m
Max. outreach		10.33 m
Overhang		7.43 m
Pendular arm rotation (left / right)		90 ° / 90 °
Pendular arm rotation (top / bottom)		+65 ° / -59.50 °
Platform capacity	Q	250 kg
Turret rotation		360 °
Platform rotation (right / left)		90 ° / 90 °
Number of people (indoor / outdoor)		2 / 2
Weight and dimensions		
Platform weight*		7550 kg
Platform dimensions (length x width)	lp / ep	1.80 m x 0.80 m
Floor height (access)	h20	0.45 m
Overall length	l1	7.61 m
Overall width	b1	2.32 m
Overall height	h17	2.48 m
Overall length (stowed)	l9	5.43 m
Overall height (stowed)	h18 ***	2.52 m
Counterweight offset (turret at 90°)	a7	0.40 m
Counterweight Oversize / Reach		0.40 m
External turning radius	Wa3	3.75 m
Ground clearance at centre of wheelbase	m2	0.40 m
Wheelbase	y	2.30 m
Performances		
Drive speed - stowed		5 km/h
Drive speed - raised		1 km/h
Gradeability		45 %
Permissible leveling		5 °
Wheels		
Tires type		Foam Filled Non Marking
Standard tires		914 x 381 mm / 36X15D610
Drive wheels (front / rear)		2 / 2
Steering wheels (front / rear)		2 / 2
Braking wheels (front / rear)		0 / 2
Engine/Battery		
Battery voltage		48 V
Battery nominal voltage / capacity		48 V / 480 Ah
Battery energy		23 kWh
On-board charger (V / A)		48 V / 60 A
Miscellaneous		
Ground Pressure		10 dan/cm2
Hydraulic Pressure		240 bar
Hydraulic tank capacity		24 l
Noise to environment (LWA)		< 98 dB
Standards compliance		
This machine is in compliance with:		European directives: 2006/42/EC- Machinery (revised EN280:2013) - 2004/108/EC (EMC) - 2006/95/EC (Low voltage)

*Varies according to options and standards of the country to which the machine is delivered

** According to "REDUCE cycle"

180 ATJ e RC - Abaques

Load Chart for MEWP Metric

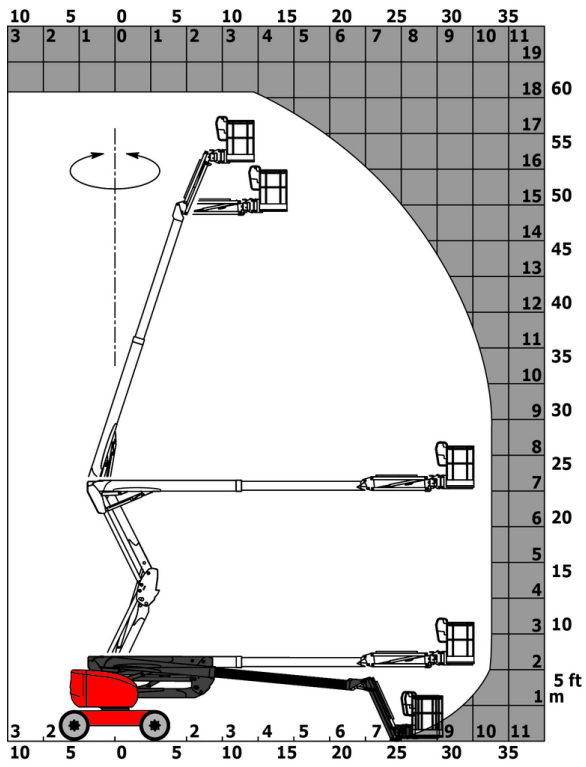

180 ATJ e RC - Schémas d'encombrement

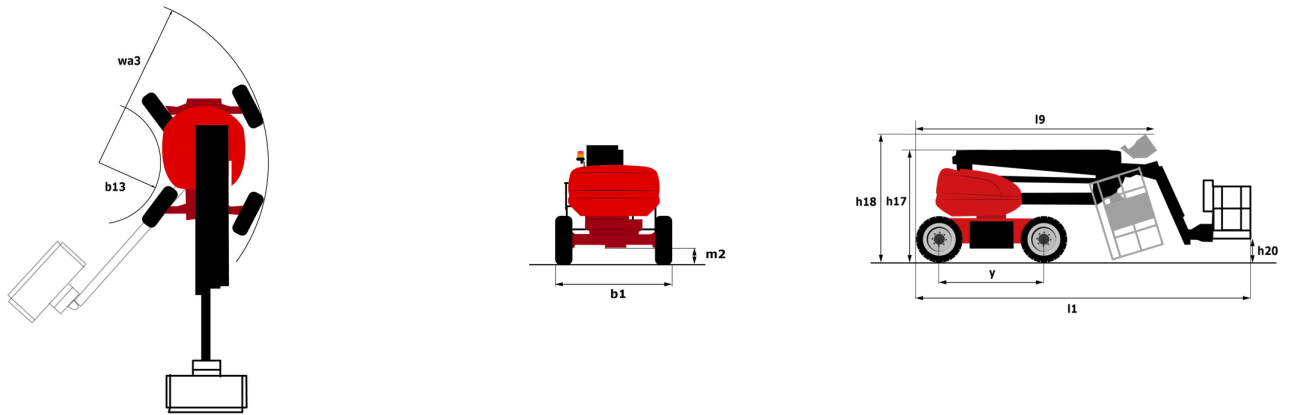

Équipements

Standard

220V predisposition in the platform
 4 simultaneous movements
 4 wheel drive
 4 wheel steer with crab mode
 Audible alarm and illuminated indicator lamp (leveling, overload, lowering)
 Backup electrical pump
 CAN bus technology
 Continuous turret rotation
 Differential locking on rear axle
 Easy Link with 2 year Service
 Easy Manager
 Emergency stop button in platform and on frame
 Fully galvanized basket with demountable floor
 Galvanized basket 1,800 mm
 Hom in the platform
 Hour meter
 LED rotating beacon
 Large color screen on turret
 Leveling unlocking
 Load sensing pump
 Operator presence pedal
 Oscillating front axle
 Rear axle with limited slip differential
 Reserve mode
 Screen information in the basket
 Secondary Protection System (SPS)
 Secondary Protection System (SPS) - With LED red strobe lights
 Simplified lifting system without spreader bar
 Slings and securing rings
 Steer and rotate
 Turret orientation information

Optionnel

110 V electric plug 16A
 Audio warning on all motion
 Audio warning on all motion - White noise
 Audio warning on movement
 Audio warning on translation - White noise
 Biodegradable hydraulic oil - Grade 32
 Biodegradable oil
 Bottom screen protection
 Continuous turret rotation
 Digicode anti-theft device
 Earthing and shortcircuiting pre-fitting (Bolted ball)
 Easy Link - With access control keypad
 Easy link with remote lock
 Electric centralized filling
 External pneumatic supply source
 Foam-filled tires 914 x 381 mm / 36X15D610
 Fully galvanized basket 1800mm / 5'11" with lateral door
 Galvanized basket 2,100 mm
 Galvanized basket 2.100 mm / 6'11" with lateral door
 Hydraulic oil heater
 Key lock on turret cover
 Lighting pack
 Locking the telescope by parameter setting
 OSS - Operation Safety System
 Packing for containerization
 Personalized paintwork
 Rail protection
 Safety kit - Harness + helmet
 Socket 230 V + differential circuit breaker
 Two safety kits (helmet + harness)
 Water heater
 Water predisposition
 Working light (x1) on basket

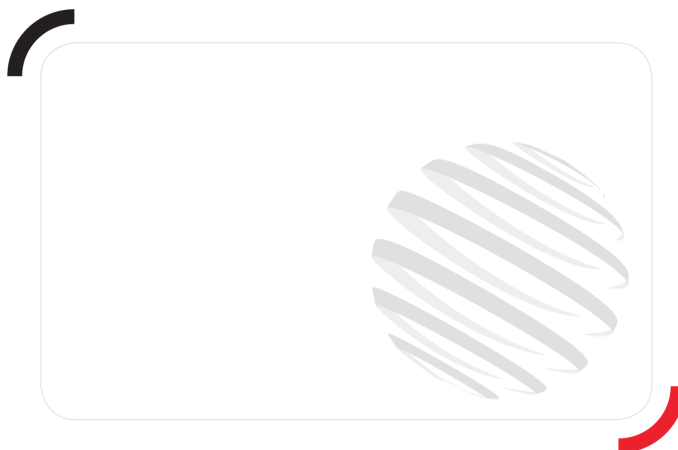

Siège Social

B.P. 249 - 430 rue de l'Aubinière
44150 Ancenis Cedex - France

Tel: +33 (0)2 40 09 10 11 - Fax: +33 (0)2 40 09 10 97

www.manitou.com



Cette publication présente le descriptif des versions et possibilités de configuration des produits Manitou qui peuvent différer en équipement. Les équipements présentés dans cette brochure peuvent être de série, en option, ou non disponibles suivant les versions. Manitou se réserve le droit, à tout moment et sans préavis, de modifier les spécifications décrites et représentées. Les spécifications portées n'engagent pas le constructeur. Pour plus de détails, contactez votre concessionnaire Manitou. Document non contractuel. Présentation des produits non contractuelle. Liste des spécifications non exhaustive. Les logos ainsi que l'identité visuelle de l'entreprise sont la propriété de Manitou et ne peuvent être utilisés sans autorisation. Tous droits réservés. Les photos et schémas contenus dans la présente brochure ne sont fournis qu'à des fins de consultation et à titre indicatif.

Manitou BF SA - Société anonyme à conseil d'administration - Capital social : 39 668 399 euros - 857 802 508 RCS Nantes