

Ficha técnica :

180 ATJ E

OXYGEN



 **MANITOU**
HANDLING YOUR WORLD

Capacities		Métrico
Working height	h21	18.19 m
Platform height	h7	16.19 m
Max. outreach		10.33 m
Overhang		7.43 m
Pendular arm rotation (left / right)		90 ° / 90 °
Pendular arm rotation (top / bottom)		+65 ° / -59.50 °
Platform capacity	Q	250 kg
Turret rotation		350 °
Platform rotation (right / left)		90 ° / 90 °
Number of people (indoor / outdoor)		2 / 2
Weight and dimensions		
Platform weight*		7550 kg
Platform dimensions (length x width)	lp / ep	1.80 m x 0.76 m
Floor height (access)	h20	0.45 m
Overall length	l1	7.61 m
Overall width	b1	2.32 m
Overall height	h17	2.48 m
Overall length (stowed)	l9	5.43 m
Overall height (stowed)	h18 ***	2.83 m
Counterweight offset (turret at 90°)	a7	0.40 m
Counterweight Oversize / Reach		0.40 m
External turning radius	Wa3	3.75 m
Ground clearance at centre of wheelbase	m2	0.40 m
Wheelbase	y	2.30 m
Performances		
Drive speed - stowed		5.30 km/h
Drive speed - raised		0.70 km/h
Gradeability		45 %
Permissible leveling		5 °
Wheels		
Tires type		Foam Filled Non Marking
Standard tires		914 x 381 mm / 36X15D610
Drive wheels (front / rear)		2 / 2
Steering wheels (front / rear)		2 / 2
Braking wheels (front / rear)		0 / 2
Engine/Battery		
Battery voltage		48 V
Battery nominal voltage / capacity		48 V / 480 Ah
Battery energy		23 kWh
On-board charger (V / A)		48 V / 60 A
Miscellaneous		
Number of cycles with STD Battery (HIRD)		48
Ground Pressure		10.50 dan/cm ²
Hydraulic Pressure		240 bar
Hydraulic tank capacity		24 l
Sound pressure level (platform work station) (platform work station)		70 dB
Vibration on hands/arms		< 2.50 m/s ²
Standards compliance		
This machine is in compliance with:		European directives: 2006/42/EC- Machinery (revised EN280:2013) - 2004/108/EC (EMC) - 2006/95/EC (Low voltage)

*Varies according to options and standards of the country to which the machine is delivered

** According to "REDUCE cycle"

180 ATJ e - Diagramas de carga

Load Chart for MEWP Metric

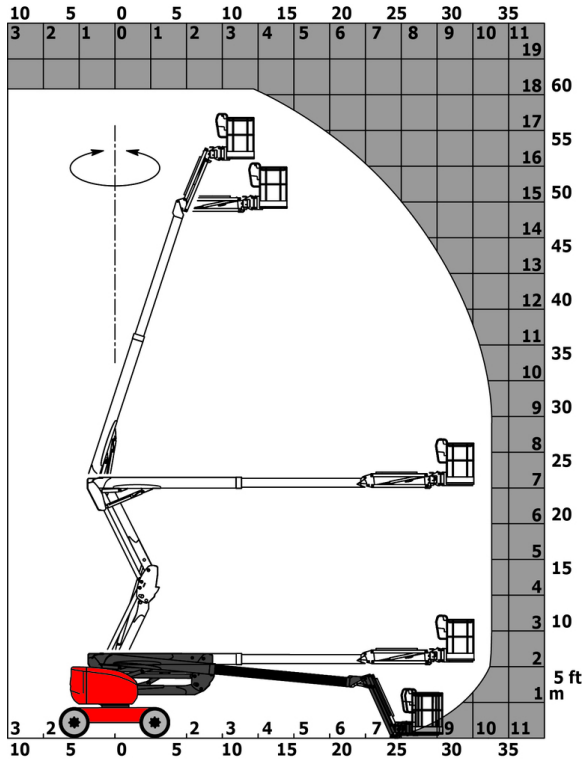

180 ATJ e - Diagrama dimensional

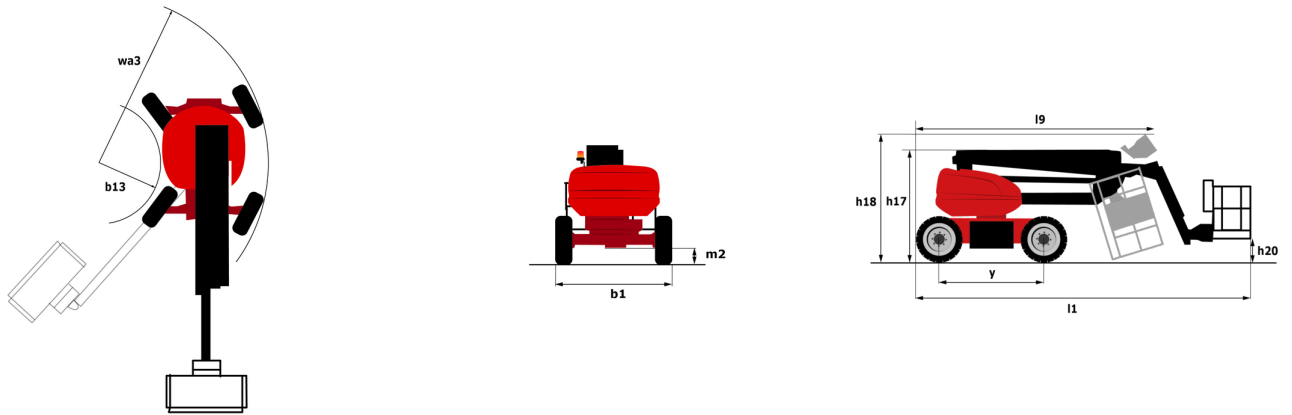

Equipamiento

Estándar

220V predisposition in the platform
 4 simultaneous movements
 4 wheel drive
 4 wheel steer with crab mode
 Audible alarm and illuminated indicator lamp (leveling, overload, lowering)
 Backup electrical pump
 Basket 1,800 mm
 CAN bus technology
 Differential locking on rear axle
 Easy Link with 2 year Service
 Easy Manager
 Emergency stop button in platform and on frame
 Fully galvanized basket with demountable floor
 Horn in the platform
 Hour meter
 LED rotating beacon
 Large color screen on turret
 Leveling unlocking
 Load sensing pump
 Operator presence pedal
 Oscillating front axle
 Rear axle with limited slip differential
 Reserve mode
 Screen information in the basket
 Simplified lifting system without spreader bar
 Slings and securing rings
 Steer and rotate
 Turret orientation information

Opcional

Audio warning on all motion - White noise
 Biodegradable hydraulic oil - Grade 32
 Biodegradable oil
 Bottom screen protection
 Continuous turret rotation
 Digicode anti-theft device
 Easy Link - With access control keypad
 Easy link with remote lock
 Electric centralized filling
 External pneumatic supply source
 Foam-filled tires 914 x 381 mm / 36X15D610
 Fully galvanized basket 1800mm / 5'11" with lateral door
 Galvanized basket 2,100 mm
 Galvanized basket 2.100 mm / 6'11" with lateral door
 Key lock on turret cover
 Lighting pack
 Locking the telescope by parameter setting
 OSS - Operation Safety System
 Personalized paintwork
 Safety kit - Harness + helmet
 Socket 230 V + differential circuit breaker
 Water heater
 Water predisposition



Oficina Central

B.P. 249 - 430 rue de l'Aubinière

44150 Ancenis Cedex - Francia

Tel.: 00 33 (0)2 40 09 10 11 - Fax: 00 33 (0)2 40 09 10 97

www.manitou.com



Esta publicación describe las versiones y posibilidades de configuración de los productos Manitou que puedan diferir en equipamiento. Los equipamientos presentados en este folleto pueden ser de serie, opcionales o no estar disponibles en algunas versiones. Manitou se reserva el derecho, en cualquier momento y sin previo aviso, de modificar las especificaciones descritas y representadas. Las especificaciones aportadas no comprometen al fabricante. Para más información, póngase en contacto con su concesionario Manitou. Documento no contractual. Presentación de los productos no contractual. Lista de especificaciones no exhaustiva. Los logos y la identidad visual de la empresa son propiedad de Manitou y no pueden ser utilizados sin autorización. Todos los derechos reservados. Las fotos y los esquemas contenidos en este folleto se ofrecen para consulta y a título indicativo solamente.

Manitou BF SA - Sociedad anónima con Consejo de Administración - Capital social: 39 668 399 euros - 857 802 508 RCS Nantes