

Fiche technique :

80 VJR

OXYGEN
by MANITOU



 **MANITOU**
HANDLING YOUR WORLD

Capacités		Métrique
Working height	h21	7.65 m
Platform height	h7	5.65 m
Max. outreach		3.20 m
Overhang		4.12 m
Pendular arm rotation (top / bottom)		+62 ° / 51 °
Platform capacity	Q	200 kg
Turret rotation		350 °
Number of people (indoor / outdoor)		2 / 1
Weight and dimensions		
Platform weight*		2410 kg
Platform dimensions (length x width)	lp / ep	1.19 m x 0.93 m
Floor height (access)	h20	0.41 m
Overall length	l1	2.95 m
Overall width	b1	0.99 m
Overall height	h17	1.99 m
Jib length	l13	1.61 m
Counterweight offset (turret at 90°)	a7	0.09 m
External turning radius	Wa3	2.10 m
Ground clearance under pothole protection	m6	0.03 m
Ground clearance at centre of wheelbase	m2	0.09 m
Wheelbase	y	1.20 m
Performances		
Drive speed - stowed		4.50 km/h
Drive speed - raised		0.65 km/h
Gradeability		25 %
Permissible leveling		2 °
Wheels		
Tires type		Non marking
Standard tires		16.5-11 1/4 / 406 x 127 mm
Drive wheels (front / rear)		0 / 2
Steering wheels (front / rear)		2 / 0
Braking wheels (front / rear)		0 / 2
Engine/Battery		
Electric engine power rating		2 x 0.77 kW
Lift motor power		3 kW
Number of hydraulic pump / Capacity of hydraulic pump		2 x 3.75 cm³
Battery voltage		24 V
Battery capacity		250 Ah
On-board charger (V / A)		24 V / 30 A
Miscellaneous		
Number of cycles with STD Battery (HIRD)		32
Ground Pressure		11.10 dan/cm2
Hydraulic Pressure		140 bar
Hydraulic tank capacity		22 l
Noise to environment (LwA)		< 70 dB
Vibration on hands/arms		< 0.50 m/s²
Standards compliance		
This machine is in compliance with:		European directives: 2006/42/EC- Machinery (revised EN280-1:2022) - 2004/108/EC (EMC) - 2006/95/EC (Low voltage)

*Varies according to options and standards of the country to which the machine is delivered

80 VJR - Abaques

Load Chart for MEWP Metric

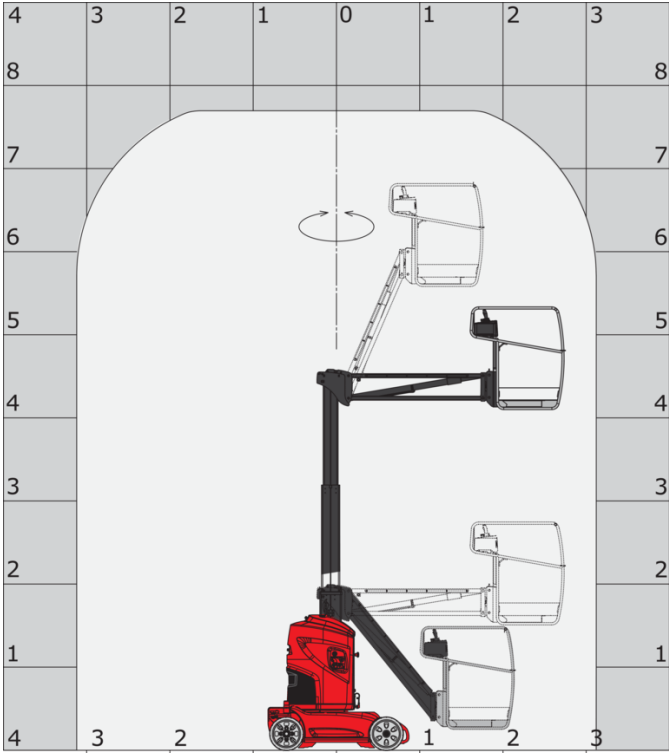

80 VJR - Schémas d'encombrement

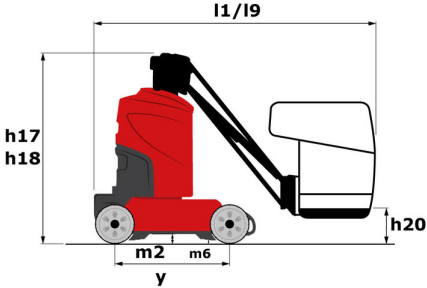
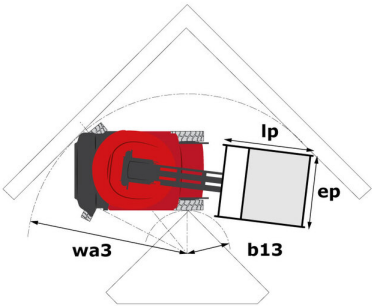

Équipements

Standard

Audible alarm and illuminated indicator lamp (leveling, overload, lowering)

CAN bus technology

Easy Link with 2 year Service

Emergency stop button in platform and on frame

Fixed pothole protection

Fork pockets

Hom in the platform

Manual emergency lowering

Multi-function smartview display

Multi-voltage integrated charger

Negative-type braking on rear wheels

Non-marking rubber tyres

Pendular arm

Proportional controls

Secondary Protection System (SPS)

Slinging and securing rings

Tool box in platform

Traction battery

Travel possible at maximum height

lace floor basket

Optionnel

110 or 230V plug with differential circuit breaker

Audio warning on all motion

Audio warning on descent

Audio warning on movement

Biodegradable hydraulic oil - Grade 32

Centralized filling of the battery

Cold weather protection oil

Easy Link - With access control keypad

Easy link with remote lock

LED strobe Light on the basket

LED strobe light on the turret

Maintenance-free battery

Personalized paintwork

Pre fitting electric supply IP65

Protective cover for control panel

Safety harness reminder indicator

Safety kit - Harness + helmet

Turret orientation information

Working light (x1) on basket



Siège Social

B.P. 249 - 430 rue de l'Aubinière

44150 Ancenis Cedex - France

Tel: +33 (0)2 40 09 10 11 - Fax: +33 (0)2 40 09 10 97

www.manitou.com



Cette publication présente le descriptif des versions et possibilités de configuration des produits Manitou qui peuvent différer en équipement. Les équipements présentés dans cette brochure peuvent être de série, en option, ou non disponibles suivant les versions. Manitou se réserve le droit, à tout moment et sans préavis, de modifier les spécifications décrites et représentées. Les spécifications portées n'engagent pas le constructeur. Pour plus de détails, contactez votre concessionnaire Manitou. Document non contractuel. Présentation des produits non contractuelle. Liste des spécifications non exhaustive. Les logos ainsi que l'identité visuelle de l'entreprise sont la propriété de Manitou et ne peuvent être utilisés sans autorisation. Tous droits réservés. Les photos et schémas contenus dans la présente brochure ne sont fournis qu'à des fins de consultation et à titre indicatif.

Manitou BF SA - Société anonyme à conseil d'administration - Capital social : 39 668 399 euros - 857 802 508 RCS Nantes