

Technical sheet :

# 100 VJR

OXYGEN  
by MANITOU



 **MANITOU**  
HANDLING YOUR WORLD

| Capacities  |         | Metric   |
|---|---------|--|
| Working height  | h21     | 9.90 m   |
| Platform height                                       | h7      | 7.90 m   |
| Max. outreach   |         | 3.10 m   |
| Overhang  |         | 6.56 m   |
| Pendular arm rotation (top / bottom)                  |         | +58 ° / -56 °  |
| Platform capacity                                     | Q       | 200 kg   |
| Turret rotation                                       |         | 350 °  |
| Number of people (indoor / outdoor)                   |         | 2 / 1  |
| Weight and dimensions                                 |         |  |
| Platform weight*                                      |         | 2820 kg  |
| Platform dimensions (length x width)                  | lp / ep | 1.19 m x 0.93 m  |
| Floor height (access)                                 | h20     | 0.46 m   |
| Overall length  | l1      | 2.80 m   |
| Overall width   | b1      | 0.99 m   |
| Overall height  | h17     | 1.99 m   |
| Jib length  | l13     | 1.45 m   |
| Counterweight offset (turret at 90°)                  | a7      | 0.09 m   |
| External turning radius                               | Wa3     | 2.02 m   |
| Ground clearance under pothole protection             | m6      | 0.03 m   |
| Ground clearance at centre of wheelbase               | m2      | 0.09 m   |
| Wheelbase   | y       | 1.20 m   |
| Performances  |         |  |
| Drive speed - stowed                                  |         | 5 km/h   |
| Drive speed - raised                                  |         | 0.65 km/h  |
| Gradeability  |         | 25 %   |
| Permissible leveling                                  |         | 2 °  |
| Wheels  |         |  |
| Tires type  |         | Non marking  |
| Standard tires  |         | 16.5-11 1/4 / 406 x 127 mm   |
| Drive wheels (front / rear)                           |         | 0 / 2  |
| Steering wheels (front / rear)                        |         | 2 / 0  |
| Braking wheels (front / rear)                         |         | 0 / 2  |
| Engine/Battery  |         |  |
| Electric engine power rating                          |         | 2 x 0.77 kW  |
| Lift motor power                                      |         | 3 kW   |
| Number of hydraulic pump / Capacity of hydraulic pump |         | 2 x 3.75 cm <sup>3</sup>   |
| Battery voltage                                       |         | 24 V   |
| Battery capacity                                      |         | 250 Ah   |
| On-board charger (V / A)                              |         | 24 V / 30 A  |
| Miscellaneous   |         |  |
| Number of cycles with STD Battery (HIRD)              |         | 29   |
| Ground Pressure                                       |         | 11.80 dan/cm <sup>2</sup>  |
| Hydraulic Pressure                                    |         | 140 bar  |
| Hydraulic tank capacity                               |         | 22 l   |
| Vibration on hands/arms                               |         | < 0.50 m/s <sup>2</sup>  |
| Standards compliance                                  |         |  |
| This machine is in compliance with:                   |         | European directives: 2006/42/EC- Machinery (revised EN280-1:2022) - 2004/108/EC (EMC) - 2006/95/EC (Low voltage) |

\*Varies according to options and standards of the country to which the machine is delivered

# 100 VJR - Load chart

Load Chart for MEWP Metric

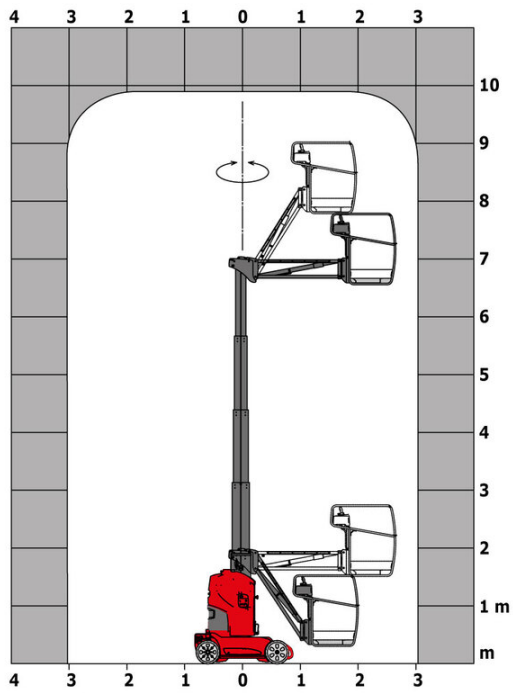

# 100 VJR - Dimensional drawing



# Equipment

---

## Standard

Audible alarm and illuminated indicator lamp (leveling, overload, lowering)

CAN bus technology

Easy Link with 2 year Service

Emergency stop button in platform and on frame

Fixed pothole protection

Fork pockets

Hom in the platform

Manual emergency lowering

Multi-function smartview display

Multi-voltage integrated charger

Negative-type braking on rear wheels

Non-marking rubber tyres

Pendular arm

Platform with open-work floor

Proportional controls

Secondary Protection System (SPS)

Slings and securing rings

Tool box in platform

Traction battery

## Optional

110 or 230V plug with differential circuit breaker

Audio warning on all motion

Audio warning on descent

Audio warning on movement

Biodegradable hydraulic oil - Grade 32

Centralized filling of the battery

Cold weather protection oil

Easy Link - With access control keypad

Easy link with remote lock

LED strobe Light on the basket

LED strobe light on the turret

Maintenance-free battery

Personalized paintwork

Pre fitting electric supply IP65

Protective cover for control panel

Safety harness reminder indicator

Safety kit - Harness + helmet

Turret orientation information

Working light (x1) on basket



**Head Office**

B.P. 249 - 430 rue de l'Aubinière

44150 Ancenis Cedex - France

Tel: +33 (0)2 40 09 10 11 - Fax: +33 (0)2 40 09 10 97

[www.manitou.com](http://www.manitou.com)



This publication provides a description of the configuration versions and options for Manitou products, which may differ for equipment. The equipment presented in this brochure may be part of a series, as an option, or it may not be available, depending on the versions. Manitou reserves the right, at any time and without notice, to amend the specifications described and represented. The specifications provided do not bind the manufacturer. For more details, please contact your Manitou agent. This is not a contractually binding document. The presentation of the products is not contractually binding. List of specifications non-exhaustive. The logos as well as the visual identity of the company are owned by Manitou and cannot be used without authorisation. All rights reserved. The photos and diagrams contained in this brochure are only provided for consultation and information purposes.

MANITOU BF SA - Limited company with board of directors - Share capital: 39,668,399 euros - 857 802 508 RCS Nantes