

Fiche technique :

# 150 AETJ-C

OXYGEN  
by MANITOU



 **MANITOU**  
HANDLING YOUR WORLD

Capacities		Métrique
Working height	h21	14.60 m
Platform height	h7	12.60 m
Max. outreach		7.13 m
Overhang		7.07 m
Pendular arm rotation (top / bottom)		+65 ° / -65 °
Platform capacity	Q	220 kg
Turret rotation		355 °
Platform rotation (right / left)		66 ° / 59 °
Number of people (indoor / outdoor)		2 / 2
Weight and dimensions		
Platform weight*		6975 kg
Platform dimensions (length x width)	lp / ep	1.20 m x 0.92 m
Floor height (access)	h20	0.40 m
Overall length	l1	6.05 m
Overall width	b1	1.50 m
Overall height	h17	1.97 m
Overall length (stowed)	l9	4.40 m
Overall height (stowed)	h18 ***	2.08 m
Jib length	l13	1.26 m
Counterweight offset (turret at 90°)	a7	0.12 m
External turning radius	Wa3	3.96 m
Ground clearance at centre of wheelbase	m2	0.14 m
Wheelbase	y	2 m
Performances		
Drive speed - stowed		5 km/h
Drive speed - raised		0.60 km/h
Gradeability		22 %
Permissible leveling		3 °
Wheels		
Tires type		Solid non-marking tires
Standard tires		24 x 7.5 in / 600 x 190 mm
Drive wheels (front / rear)		0 / 2
Steering wheels (front / rear)		2 / 0
Braking wheels (front / rear)		0 / 2
Engine/Battery		
Electric engine power rating		2 x 3 kW
Lift motor power		3.70 kW
Battery nominal voltage / capacity		48 V / 240 Ah
Battery energy		11 kWh
On-board charger (V / A)		48 V / 30 A
Miscellaneous		
Number of cycles with STD Battery (HIRD)		46
Ground Pressure		13.50 dan/cm <sup>2</sup>
Hydraulic Pressure		210 bar
Hydraulic tank capacity		15 l
Noise to environment (LWA)		< 70 dB
Vibration on hands/arms		< 0.52 m/s <sup>2</sup>
Standards compliance		
This machine is in compliance with:		European directives: 2006/42/EC- Machinery (revised EN280-1:2022) - 2004/108/EC (EMC) - 2006/95/EC (Low voltage)

\*Varies according to options and standards of the country to which the machine is delivered

# 150 AETJ-C - Abaques

Load Chart metric

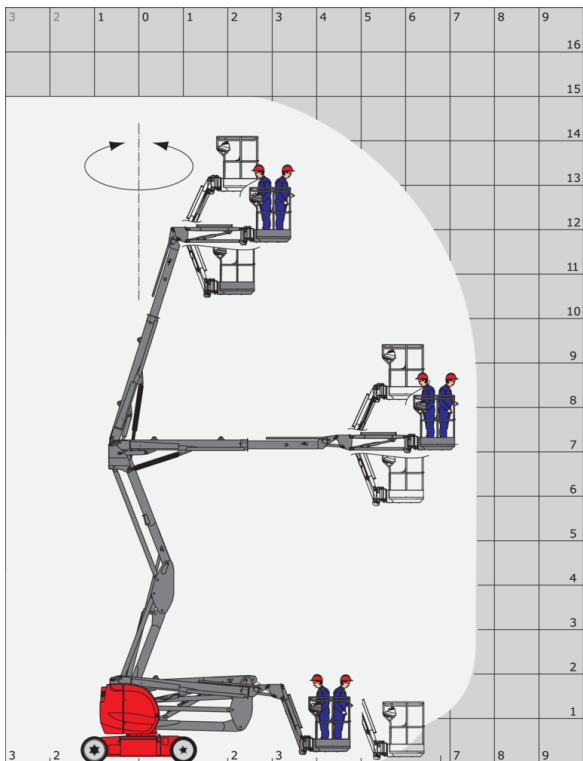

# 150 AETJ-C - Schémas d'encombrement

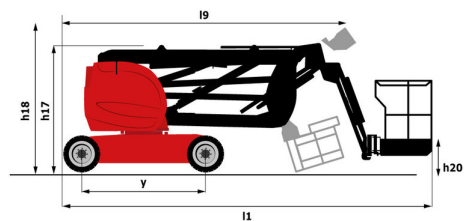
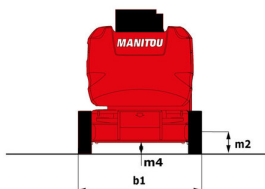
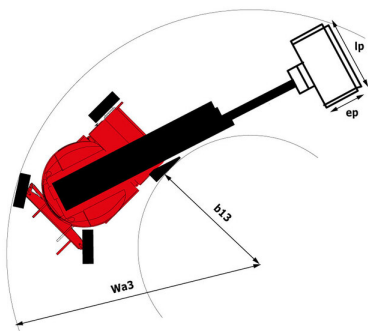

# Équipements

## Standard

230V Predisposition  
Audible alarm and illuminated indicator lamp (leveling, overload, lowering)  
CAN bus technology  
Easy Link with 2 year Service  
Emergency stop button in platform and on frame  
Hom in the platform  
Manual emergency lowering  
Multi-function smartview display  
Multi-voltage integrated charger  
Negative-type braking on rear wheels  
Non-marking rubber tyres  
Pendular arm  
Platform with open-work floor  
Proportional controls  
Secondary Protection System (SPS)  
Slinging and securing rings  
Tool box in platform  
Traction battery  
Travel possible at maximum height

## Optionnel

110 or 230V plug with differential circuit breaker  
Audio warning on all motion  
Audio warning on movement  
Biodegradable hydraulic oil - Grade 32  
Centralized filling of the battery  
Cold weather protection oil  
Easy Link - With access control keypad  
Easy link with remote lock  
External pneumatic supply source  
High capacity starting battery  
Maintenance-free battery  
Non-marking Foam Inflated Tires 914 x 381 mm / 36x15D610  
Personalized paintwork  
Protective cover for control panel  
Rail protection  
Safety kit - Harness + helmet  
Turret orientation information  
Water predisposition  
Working light (x1) on basket



**Siège Social**

B.P. 249 - 430 rue de l'Aubinière

44150 Ancenis Cedex - France

Tel: +33 (0)2 40 09 10 11 - Fax: +33 (0)2 40 09 10 97

[www.manitou.com](http://www.manitou.com)



Cette publication présente le descriptif des versions et possibilités de configuration des produits Manitou qui peuvent différer en équipement. Les équipements présentés dans cette brochure peuvent être de série, en option, ou non disponibles suivant les versions. Manitou se réserve le droit, à tout moment et sans préavis, de modifier les spécifications décrites et représentées. Les spécifications portées n'engagent pas le constructeur. Pour plus de détails, contactez votre concessionnaire Manitou. Document non contractuel. Présentation des produits non contractuelle. Liste des spécifications non exhaustive. Les logos ainsi que l'identité visuelle de l'entreprise sont la propriété de Manitou et ne peuvent être utilisés sans autorisation. Tous droits réservés. Les photos et schémas contenus dans la présente brochure ne sont fournis qu'à des fins de consultation et à titre indicatif.

Manitou BF SA - Société anonyme à conseil d'administration - Capital social : 39 668 399 euros - 857 802 508 RCS Nantes