

Fiche technique :

150 AETJ-C

OXYGEN
by MANITOU



 **MANITOU**
HANDLING YOUR WORLD

Capacités		Métrique
Hauteur de travail	h21	14.60 m
Hauteur de plate-forme	h7	12.60 m
Déport max.		7.13 m
Surplomb		7.07 m
Rotation du bras pendulaire (haut / bas)		+65 ° / -65 °
Capacité de la nacelle	Q	220 kg
Rotation tourelle		355 °
Rotation de la nacelle (droite / gauche)		66 ° / 59 °
Nombre de personnes (intérieur / extérieur)		2 / 2
Poids et dimensions		
Poids de la nacelle*		6975 kg
Longueur du panier x Largeur du panier	lp / ep	1.20 m x 0.92 m
Hauteur plancher (accès)	h20	0.40 m
Longueur hors-tout	l1	6.05 m
Largeur hors tout	b1	1.50 m
Hauteur hors tout	h17	1.97 m
Longueur hors tout repliée	l9	4.40 m
Hauteur hors tout repliée	h18 ***	2.08 m
Longueur pendulaire	l13	1.26 m
Déport du contrepoids (tourelle à 90°)	a7	0.12 m
Rayon de braquage extérieur	Wa3	3.96 m
Garde au sol au centre de l'empattement	m2	0.14 m
Empattement	y	2 m
Performances		
Vitesse de translation - en mode transport		5 km/h
Vitesse de translation - en mode travail		0.60 km/h
Pente franchissable		22 %
Dévers autorisé		3 °
Roues		
Type de roues		Pneus pleins non-marquants
Pneus standards		24 x 7.5 in / 600 x 190 mm
Roues motrices (avant / arrière)		0 / 2
Roues directrices (avant / arrière)		2 / 0
Freinage sur roues (avants / arrière)		0 / 2
Moteur/batterie		
Puissance du moteur électrique		2 x 3 kW
Puissance du moteur d'élévation		3.70 kW
Tension nominale batterie / Capacité de la batterie		48 V / 240 Ah
Énergie batterie		11 kWh
Chargeur intégré (V / A)		48 V / 30 A
Divers		
Nombre de cycles avec batterie standard (HIRD)		46
Pression au sol		13.50 dan/cm2
Pression hydraulique		210 bar
Capacité du réservoir hydraulique		15 l
Bruit à l'environnement (LWA)		< 70 dB
Vibration sur l'ensemble mains/bras		< 0.52 m/s ²
Conformité aux normes		
Cette machine est conforme aux normes :		Directives européennes : 2006/42/CE- Machines (EN280-1:2022 révisée) - 2004/108/CE (CEM) - 2006/95/CE (Basse tension)

*Varie selon les options et les normes du pays dans lequel la machine est livrée.

150 AETJ-C - Abaques

Abaque de charge

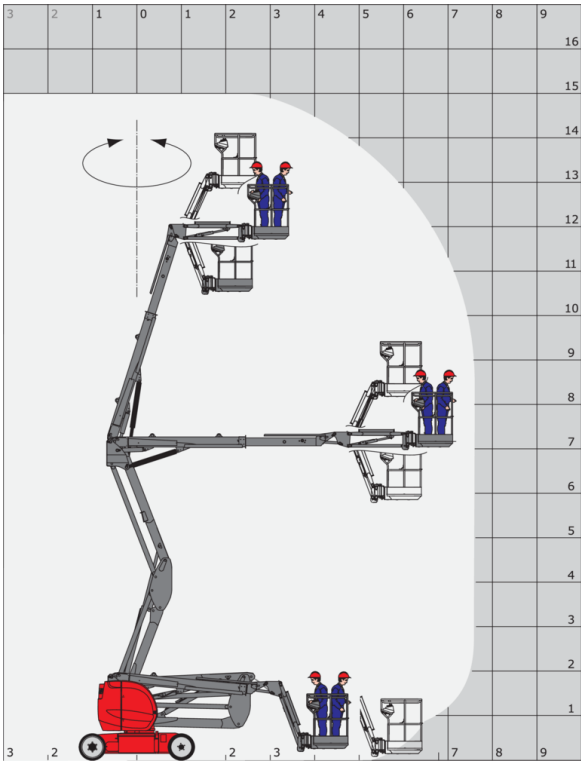

150 AETJ-C - Schémas d'encombrement



Équipements

Standard

Alarme sonore et témoins lumineux (dévers, surcharge, descente)

Anneaux d'élingage et d'arrimage

Avertisseur sonore dans le panier

Batterie de traction

Boîte à outils dans panier

Bras pendulaire

Chargeur intégré multi-tension

Commandes proportionnelles

Descente manuelle de secours

Déplacement possible à hauteur maximale

Easy link

Freinage de type négatif sur roues arrières

Interrupteur d'arrêt d'urgence dans le panier et la tourelle

Panier avec plancher ajouré

Pneus à bandages non marquants

Prédisposition 230V

Système de Protection Secondaire (SPS)

Technologie bus CAN

Écran smartview multi-fonctions

Optionnel

Avertisseur sonore sur tous mouvements

Avertisseur sur translation avant et arrière

Batterie haute performance

Batterie sans entretien

Capot de protection pour pupitre de commandes

Easy Link - Avec contrôle d'accès par clavier

Easy Link avec verrouillage à distance

Huile grand froid

Huile hydraulique biodégradable - Grade 32

Kit de sécurité - Hamais + casque

Peinture personnalisée

Phare de travail (x1) sur le panier

Pneus Gonflés à la Mousse non-marquants 914 x 381 mm / 36x15D610

Prise 110 ou 230 V avec disjoncteur différentiel

Protection lisse

Prédisposition air comprimé

Prédisposition eau

Remplissage centralisé de la batterie

Témoin orientation tourelle



Siège Social

B.P. 249 - 430 rue de l'Aubinière

44150 Ancenis Cedex - France

Tel: +33 (0)2 40 09 10 11 - Fax: +33 (0)2 40 09 10 97

www.manitou.com



Cette publication présente le descriptif des versions et possibilités de configuration des produits Manitou qui peuvent différer en équipement. Les équipements présentés dans cette brochure peuvent être de série, en option, ou non disponibles suivant les versions. Manitou se réserve le droit, à tout moment et sans préavis, de modifier les spécifications décrites et représentées. Les spécifications portées n'engagent pas le constructeur. Pour plus de détails, contactez votre concessionnaire Manitou. Document non contractuel. Présentation des produits non contractuelle. Liste des spécifications non exhaustive. Les logos ainsi que l'identité visuelle de l'entreprise sont la propriété de Manitou et ne peuvent être utilisés sans autorisation. Tous droits réservés. Les photos et schémas contenus dans la présente brochure ne sont fournis qu'à des fins de consultation et à titre indicatif.

Manitou BF SA - Société anonyme à conseil d'administration - Capital social : 39 668 399 euros - 857 802 508 RCS Nantes