

Technical sheet :

# 170 AETJ-L

OXYGEN  
by MANITOU



 **MANITOU**  
HANDLING YOUR WORLD

Capacities		Metric
Working height	h21	16.51 m
Platform height	h7	14.51 m
Max. outreach		9 m
Overhang		7 m
Pendular arm rotation (top / bottom)		+70 ° / -70 °
Platform capacity	Q	220 kg
Turret rotation		355 °
Platform rotation (right / left)		66 ° / 59 °
Number of people (indoor / outdoor)		2 / 2
Weight and dimensions		
Platform weight*		7225 kg
Platform dimensions (length x width)	lp / ep	1.20 m x 0.92 m
Floor height (access)	h20	0.40 m
Overall length	l1	6.84 m
Overall width	b1	1.75 m
Overall height	h17	1.97 m
Overall length (stowed)	l9	5.12 m
Overall height (stowed)	h18 ***	2.04 m
Jib length	l13	1.26 m
Counterweight offset (turret at 90°)	a7	0.08 m
External turning radius	Wa3	4.30 m
Ground clearance at centre of wheelbase	m2	0.14 m
Wheelbase	y	2 m
Performances		
Drive speed - stowed		5 km/h
Drive speed - raised		0.60 km/h
Gradeability		22 %
Permissible leveling		3 °
Wheels		
Tires type		Solid non-marking tires
Standard tires		24 x 7.5 in / 600 x 190 mm
Drive wheels (front / rear)		0 / 2
Steering wheels (front / rear)		2 / 0
Braking wheels (front / rear)		0 / 2
Engine/Battery		
Electric engine power rating		2 x 3 kW
Lift motor power		3.70 kW
Battery voltage		48 V
Battery nominal voltage / capacity		48 V / 240 Ah
Battery energy		11 kWh
On-board charger (V / A)		48 V / 30 A
Miscellaneous		
Number of cycles with STD Battery (HIRD)		46
Ground Pressure		16.60 dan/cm2
Hydraulic Pressure		210 bar
Hydraulic tank capacity		15 l
Vibration on hands/arms		< 0.66 m/s <sup>2</sup>
Standards compliance		
This machine is in compliance with:		European directives: 2006/42/EC- Machinery (revised EN280-1:2022) - 2004/108/EC (EMC) - 2006/95/EC (Low voltage)

\*Varies according to options and standards of the country to which the machine is delivered

# 170 AETJ-L - Load chart

Load Chart metric



# 170 AETJ-L - Dimensional drawing

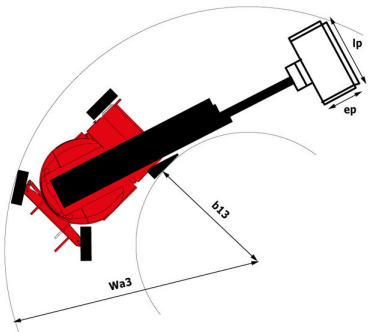

# Equipment

## Standard

230V Predisposition  
Audible alarm and illuminated indicator lamp (leveling, overload, lowering)  
CAN bus technology  
Easy Link with 2 year Service  
Emergency stop button in platform and on frame  
Hom in the platform  
Manual emergency lowering  
Multi-function smartview display  
Multi-voltage integrated charger  
Negative-type braking on rear wheels  
Non-marking rubber tyres  
Pendular arm  
Platform with open-work floor  
Proportional controls  
Secondary Protection System (SPS)  
Slinging and securing rings  
Tool box in platform  
Traction battery  
Travel possible at maximum height

## Optional

110 or 230V plug with differential circuit breaker  
Audio warning on all motion  
Audio warning on movement  
Biodegradable hydraulic oil - Grade 32  
Centralized filling of the battery  
Cold weather protection oil  
Easy Link - With access control keypad  
Easy link with remote lock  
External pneumatic supply source  
High capacity starting battery  
Maintenance-free battery  
Non-marking Foam Inflated Tires 914 x 381 mm / 36x15D610  
Personalized paintwork  
Protective cover for control panel  
Rail protection  
Safety kit - Harness + helmet  
Turret orientation information  
Water predisposition  
Working light (x1) on basket



**Head Office**

B.P. 249 - 430 rue de l'Aubinière

44150 Ancenis Cedex - France

Tel: +33 (0)2 40 09 10 11 - Fax: +33 (0)2 40 09 10 97

[www.manitou.com](http://www.manitou.com)



This publication provides a description of the configuration versions and options for Manitou products, which may differ for equipment. The equipment presented in this brochure may be part of a series, as an option, or it may not be available, depending on the versions. Manitou reserves the right, at any time and without notice, to amend the specifications described and represented. The specifications provided do not bind the manufacturer. For more details, please contact your Manitou agent. This is not a contractually binding document. The presentation of the products is not contractually binding. List of specifications non-exhaustive. The logos as well as the visual identity of the company are owned by Manitou and cannot be used without authorisation. All rights reserved. The photos and diagrams contained in this brochure are only provided for consultation and information purposes.

MANITOU BF SA - Limited company with board of directors - Share capital: 39,668,399 euros - 857 802 508 RCS Nantes