

Technical sheet :

SE 1932

OXYGEN



 **MANITOU**
HANDLING YOUR WORLD

Capacities		Imperial
Working height	h21	25 ft 7 in
Working height maximum (indoor)	h21	25 ft 7 in
Working height maximum (outdoor)	h21'	25 ft 7 in
Platform height maximum (indoor)	h7	19 ft
Platform height maximum (outdoor)	h7'	19 ft
Platform capacity	Q	507 lb
Max. capacity on the extension deck		254 lb
Number of people (indoor / outdoor)		2 / 1
Weight and dimensions		
Platform weight*		3307 lb
Platform dimensions (length x width)	lp / ep	5 ft 5 in x 2 ft 6 in
Platform dimensions with extension (length x width)		8 ft 4 in x 2 ft 6 in
Floor height (access)	h20	3 ft 4 in
Overall length	l1	6 ft 2 in
Overall width	b1	2 ft 8 in
Overall height	h17	7 ft 1 in
Overall height (stowed)	h18 ***	6 ft 6 in
Deck opening length	dp	2 ft 11 in
Overall length with platform extension	l15	9 ft 1 in
Outside turning radius - platform	Wa2	5 ft 8 in
Internal turning radius		0 in
Ground clearance with pothole guards deployed	m6	0 in
Ground clearance with pothole guards folded	m2	2 in
Wheelbase	y	4 ft 7 in
Performances		
Drive speed - stowed		3 mph
Drive speed - raised		0.50 mph
Raise speed (laden) / Lower speed (laden)		17 s / 18 s
Gradeability		25 %
Indoor and outdoor max Tilt Rating (Fore and Aft / Side-to-Side)		3.50 ° / 1.50 °
Wheels		
Tires type		Non marking cushion
Standard tires		12 x 4 in / 305 x 106 mm
Drive wheels (front / rear)		2 / 0
Steering wheels (front / rear)		2 / 0
Braking wheels (front / rear)		2 / 0
Service brake		Electric
Engine/Battery		
Battery technology		Semi-traction
Drive motor power rating		2 x 0.55 kW
Battery voltage		24 V
Number of batteries / Battery capacity		4 / 185 Ah
Battery energy		4.40 kWh
On-board charger (V / A)		24 V / 30 A
Miscellaneous		
Number of cycles with STD Battery (HIRD)		146
Hydraulic Pressure		3626 PSI
Hydraulic tank capacity		3 US gal
Sound pressure level (platform work station) (LpA)		66.60 dB
Vibration on hands/arms		< 2 ft/s ²
Standards compliance		
This machine is in compliance with:		ANSI A92.20-2018 CSA B354.6 ICES-002-Issue 6 Standard Canadian EMC

*Varies according to options and standards of the country to which the machine is delivered

*** With folded guardrail

SE 1932 - Load chart

Load Chart for MEWP (Imperial)

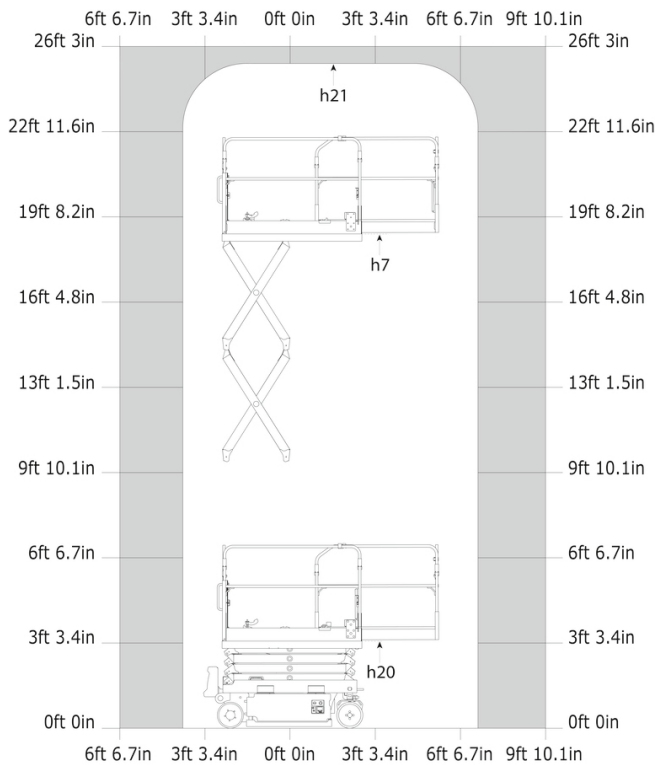

SE 1932 - Dimensional drawing

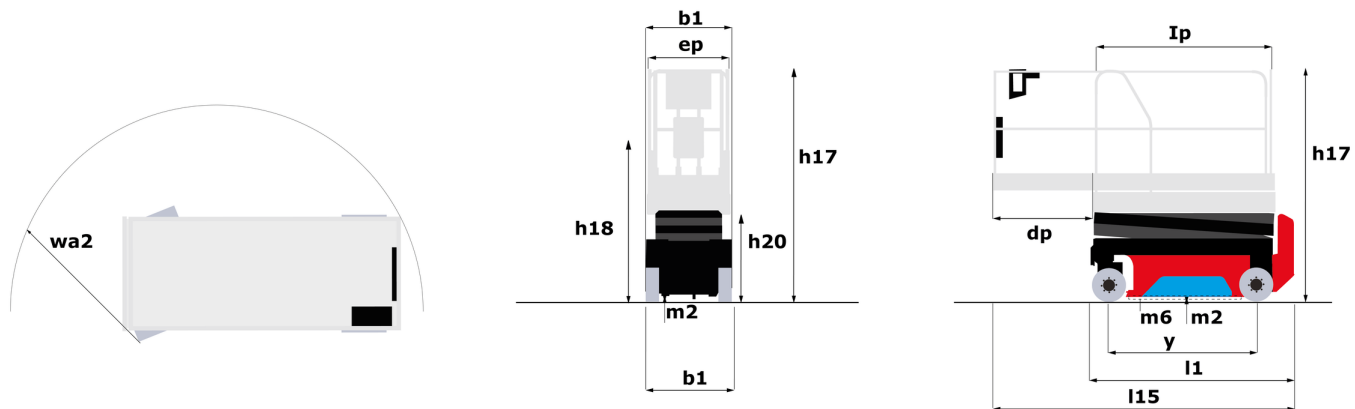

Equipment

Standard

2 swing out component trays (hydraulic/electric)
Additional foot-operated horn
Audible alarm and illuminated indicator lamp (leveling, overload, lowering)
Audio warning on all motion
Battery - 24V - 185Ah - semi-traction
Battery charge indicator lamp
CAN bus technology
Colour screen with integrated diagnostics
Easy Link with 2 year Service
Electric plug - 110V - In the basket - With differential circuit breaker - USA (B) type
Electrical front wheel brake
Emergency stop button in platform and on frame
Fold away guard rails with full height swing gate
Hour meter
Manual emergency lowering
Multi-voltage on-board charger - 24V - 30A - IES - Gel - Single-phase
Pothole protection with automatic operation
Side and rear forklift pockets
Sliding basket extension - 90 cm

Optional

Compressed air pipe pre-fitting
Easy Link - With access control keypad
Easy Link - With remote lock
Fixed anti-shearing protection
LED work light - On basket



Head Office

B.P. 249 - 430 rue de l'Aubinière
44150 Ancenis Cedex - France

Tel: +33 (0)2 40 09 10 11 - Fax: +33 (0)2 40 09 10 97

www.manitou.com



This publication provides a description of the configuration versions and options for Manitou products, which may differ for equipment. The equipment presented in this brochure may be part of a series, as an option, or it may not be available, depending on the versions. Manitou reserves the right, at any time and without notice, to amend the specifications described and represented. The specifications provided do not bind the manufacturer. For more details, please contact your Manitou agent. This is not a contractually binding document. The presentation of the products is not contractually binding. List of specifications non-exhaustive. The logos as well as the visual identity of the company are owned by Manitou and cannot be used without authorisation. All rights reserved. The photos and diagrams contained in this brochure are only provided for consultation and information purposes.

MANITOU BF SA - Limited company with board of directors - Share capital: 39,668,399 euros - 857 802 508 RCS Nantes