

Scheda tecnica :

200 ATJ RC ST5



 **MANITOU**
HANDLING YOUR WORLD

Capacities		Metico
Working height	h21	20.37 m
Platform height	h7	18.37 m
Max. outreach		11.99 m
Overhang		7.97 m
Pendular arm rotation (top / bottom)		+69 ° / -66 °
Platform capacity	Q	230 kg
Turret rotation		360 °
Platform rotation (right / left)		90 ° / 90 °
Number of people (indoor / outdoor)		2 / 2
Weight and dimensions		
Platform weight*		10050 kg
Platform dimensions (length x width)	lp / ep	2.10 m x 0.80 m
Floor height (access)	h20	500 mm
Overall length	l1	8.42 m
Overall width	b1	2.47 m
Overall height	h17	2.71 m
Overall length (stowed)	l9	6.08 m
Overall height (stowed)	h18 ***	3.12 m
Counterweight offset (turret at 90Å°)	a7	0.12 m
External turning radius	Wa3	3.90 m
Ground clearance at centre of wheelbase	m2	0.44 m
Wheelbase	y	2.40 m
Performances		
Drive speed - stowed		4.70 km/h
Drive speed - raised		0.80 km/h
Gradeability		40 %
Permissible leveling		5 °
Wheels		
Tires type		Super Elastic Solid Cushion
Standard tires		1025 x 365 mm
Drive wheels (front / rear)		2 / 2
Steering wheels (front / rear)		2 / 2
Braking wheels (front / rear)		0 / 2
Engine/Battery		
Engine brand / model		Yanmar - 3TNV88C
Engine nom		Stage IIIA
I.C. Engine power rating / Power		34 Hp / 25.50 kW
Miscellaneous		
Ground Pressure		20.65 dan/cm2
Hydraulic Pressure		335 bar
Hydraulic tank capacity		80 l
Fuel tank		78 l
Standards compliance		
This machine is in compliance with:		European directives: 2006/42/EC- Machinery (revised EN280-1:2022) - 2004/108/EC (EMC) - 2006/95/EC (Low voltage)

*Varies according to options and standards of the country to which the machine is delivered

200 ATJ RC ST5 - Diagramma di carico

Load Chart metric

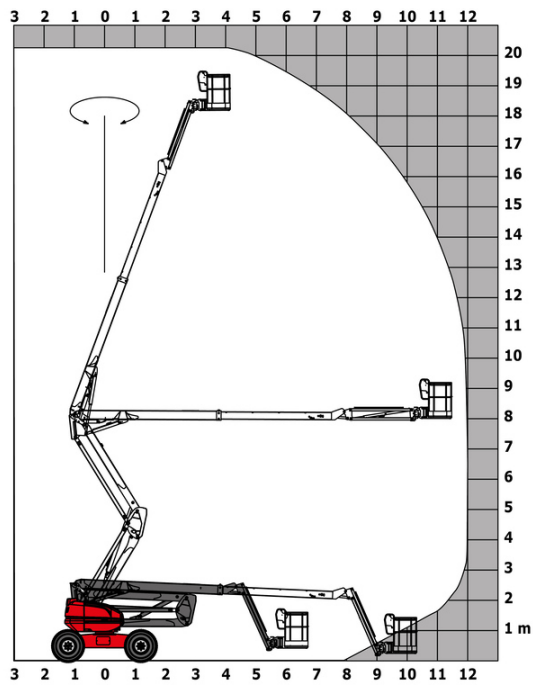

200 ATJ RC ST5 - Disegno quotato

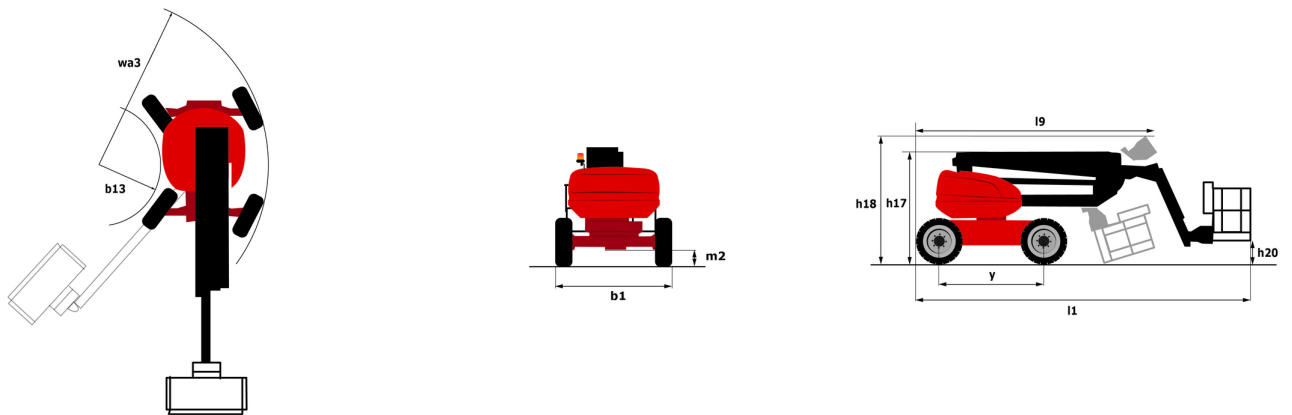

Allestimento

Standard

230V Predisposition
4 simultaneous movements
4 wheel drive
4 wheel steer with crab mode
Audible alarm and illuminated indicator lamp (leveling, overload, lowering)
Backup electrical pump
CAN bus technology
Continuous turret rotation
Dead man pedal
Differential locking on rear axle
Easy Link with 2 year Service
Emergency stop button in platform and on frame
Engine with DPF (Diesel Particulate Filter)
Front axle with limited slip
Fuel gauge with low level indicator
Galvanized basket 2,100 mm
Hour meter
Integrated diagnostic assistance
LED rotating beacon
Large color screen on turret
Management via engine speed bearing
Oscillating front axle
Proportional controls
Secondary Protection System (SPS)
Stop & Go system

Opzionale

110 or 230V plug with differential circuit breaker
Battery charger
Battery cut-off
Biodegradable hydraulic oil - Grade 32
Coded anti-start
Cold weather protection oil
Fuel tank locking cap
Galvanized basket 2,100 mm
High capacity starting battery
Key lock on turret cover
Oil tank locking cap
On-board generator (3,5 or 5 kW)
Safety kit - Harness + helmet
Screen protection on the lower box control
Socket 230 V + differential circuit breaker
Water heater



 **MANITOU**
HANDLING YOUR WORLD

Sede centrale

MANITOU ITALIA Srl

Via Cristoforo Colombo 2, Loc. Cavazzona - 41013 CASTELFRANCO EMILIA (MO)

Tel: 059.95.98.11 - Fax 059.95.98.65

www.manitou.com



Questa pubblicazione presenta la descrizione delle versioni e delle possibilità di configurazione dei prodotti Manitou, che possono differire per attrezzature. Gli allestimenti presentati nel presente opuscolo possono essere di serie, optional o non disponibili, a seconda delle versioni. Manitou si riserva il diritto di modificare, in qualsiasi momento e senza alcun preavviso, le specifiche tecniche descritte e rappresentate. Le specifiche indicate non rappresentano alcun obbligo per il costruttore. Per maggiori dettagli, rivolgersi al proprio concessionario Manitou. Documento non contrattuale. Elenco delle specifiche non esaustivo. I loghi nonché l'identità visiva dell'azienda sono di proprietà di Manitou e non possono essere utilizzati senza autorizzazione. Tutti i diritti riservati. Le immagini e gli schemi contenuti nel presente opuscolo sono forniti esclusivamente a fini di consultazione e a titolo indicativo.

Manitou BF SA - Società anonima con consiglio di amministrazione. Capitale sociale: 39,668,399 euro - 857 802 508 RCS Nantes