

Technical sheet :

# ***MXT 840 K IND (BSV)***

---



 **MANITOU**  
HANDLING YOUR WORLD

Capacities		Metric
Max. capacity	Q	4000 kg
Max. lifting height		7.60 m
Maximum outreach		4.23 m
Weight and dimensions		
Length to face of forks	l2	4.67 m
Overall width	b1	2.38 m
Overall height	h17	2.59 m
Wheelbase	y	2.58 m
Ground clearance	m4	0.37 m
Overall cab width	b4	0.85 m
Tilt-up angle	a4	12 °
Tilt-down angle	a5	134 °
External turning radius (over tyres)	Wa1	3.90 m
Unladen weight (with forks)		8525 kg
Unladen weight		8145 kg
Tires type		Inflatable
Standard tires		BKT 16.0/70-20 14PR- EM936 SPL
Forks length / width / section	l / e / s	1200 mm x 125 mm x 50 mm
Performances		
Lifting		13 s
Lowering		9 s
Extension		9 s
Retraction		5 s
Scoop		5 s
Dump		4 s
Engine		
Engine brand		Kirloskar
Engine norm		BS-V
Engine model		4R1190THT BSV
Number of cylinders / Capacity of cylinders		4 - 4760 cm³
Engine power (Hp/kW)		74.50 Hp / 54.80 kW
Max. torque / Engine rotation		400 Nm @ 1200 rpm
Drawbar pull (Laden)		8300 daN
Engine/Battery		
Battery technology		Lead acid
Battery capacity		165 Ah
Electric circuit		
Battery voltage / capacity		12 V / 165 Ah
Transmission		
Transmission type		Torque converter with manual transmission
Number of gears (forward / reverse)		4 / 4
Max. travel speed		26 km/h
Max. travel speed (may vary according to applicable regulations)		26 km/h
Parking brake		Manual
Service brake		Oil-immersed multi-discs braking on front & rear axles
Hydraulics		
Hydraulic pump type		Gear type with 2 section body
Hydraulic flow / Pressure		91.40 l/min-250 bar
Tank capacities		
Engine oil		11 l
Hydraulic oil		120 l
Fuel		100 l
Noise and vibration		
Noise at driving position (LpA)		85 dB
Noise to environment (LwA)		110 dB
Vibration on hands/arms		< 2.50 m/s²
Miscellaneous		
Steering wheels (front / rear)		2 / 2
Drive wheels (front / rear)		2 / 2
Safety / Cab certification		Standard EN 15000 / Cabin ROPS - FOPS level 2
Controls		Monolever

MXT 840 K IND (BSV) - Dimensional drawing

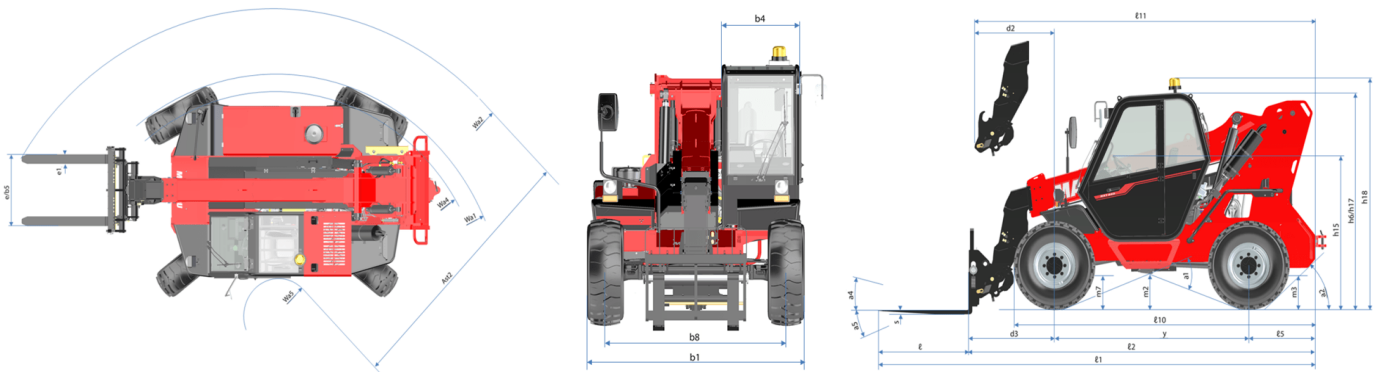

# MXT 840 K IND (BSV) - Load chart

Machine on tires with forks Metric

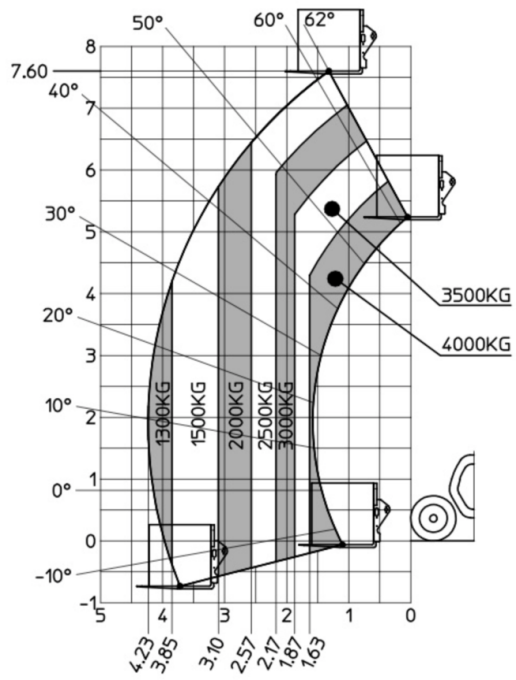



**Head Office**

B.P. 249 - 430 rue de l'Aubinière  
44150 Ancenis Cedex - France

Tel: +33 (0)2 40 09 10 11 - Fax: +33 (0)2 40 09 10 97

[www.manitou.com](http://www.manitou.com)



This publication provides a description of the configuration versions and options for Manitou products, which may differ for equipment. The equipment presented in this brochure may be part of a series, as an option, or it may not be available, depending on the versions. Manitou reserves the right, at any time and without notice, to amend the specifications described and represented. The specifications provided do not bind the manufacturer. For more details, please contact your Manitou agent. This is not a contractually binding document. The presentation of the products is not contractually binding. List of specifications non-exhaustive. The logos as well as the visual identity of the company are owned by Manitou and cannot be used without authorisation. All rights reserved. The photos and diagrams contained in this brochure are only provided for consultation and information purposes.

MANITOU BF SA - Limited company with board of directors - Share capital: 39,668,399 euros - 857 802 508 RCS Nantes