

Ficha técnica :

EP 20P EASY



 **MANITOU**
HANDLING YOUR WORLD

Technical characteristics			Métrico
1.1	Manufacturer		MANITOU
1.2	Model Name		EP 20P EASY
1.3	Power source		Electrical
1.4	Operator type		Carried
1.5	Max. capacity	Q	2000 kg
1.6	Load center of gravity	c	600 mm
1.8	Load distance, centre of drive axle to fork	x	940 mm
1.9	Wheelbase	y	1465 mm
Weight			
2.1	Service weight		785 kg
2.2	Weight on front axle (laden) / rear axle (laden)		1165 kg / 1760 kg
2.3	Weight on front axle (Unladen) / rear axle (Unladen)		610 kg / 175 kg
Wheels			
3.1	Tires type		Polyurethane
3.2	Dimensions of front wheels		230 x 75
3.3	Dimensions of rear wheels		85 x 110
3.4	Number of stabilizer wheels / Size of the stabilizer wheels		2 / 125 x 50
3.5.2	Number of drive wheels / front wheels / rear wheels		1 / 3 / 2
3.6	Front wheel gauge	b10	575 mm
3.7	Rear wheel gauge	b11	370 mm
Dimensions			
4.15	Fork height in low position	h13	85 mm
4.19	Overall length	l1	1970 mm
4.19	Overall length deployed platform	l1	2373 mm
4.20	Length to face of forks	l2	821 mm
4.21	Overall width	b1	800 mm
4.22	Forks section / width / length	s / e / l	64 mm x 170 mm x 1150 mm
4.25	Fork spread	b5	540 mm
4.32	Ground clearance at centre of wheelbase	m2	20 mm
4.33	Aisle Width for pallets 1000 x 1200 crossways	Ast	2596 mm
4.34	Aisle width for 800 x 1200 pallet lengthways	Ast	2646 mm
4.35	Turning radius	Wa	1787 mm
4.4	Mast lifting height	h3	125 mm
4.9	Height tiller min.	h14	1100 mm
4.9	Height tiller max.	h14	1419 mm
Performances			
5.1	Travel speed (laden / unladen)		7.50 km/h / 9.50 km/h
5.2	Lifting speed (laden / unladen)		0.36 m/s / 0.55 m/s
5.7	Gradeability (laden / unladen)		8 % / 16 %
5.10	Service brake		Electro magnetic
5.11	Parking brake		Handle Release
Engine			
6.1	Drive motor rating S2 60 min		1.50 kW
6.2	Lift motor rating at S3 15%		2.20 kW
6.3	Battery according to DIN 43531/35/36 A, B, C		DIN 43535-B
6.4	Battery voltage / capacity		24 V / 270 Ah
6.5	Battery weight (+/- 5%)		210 kg
Miscellaneous			
8.4	Measured/guaranteed mean noise level at the ear of the operator		< 65 dB

EP 20P Easy - Diagrama dimensional

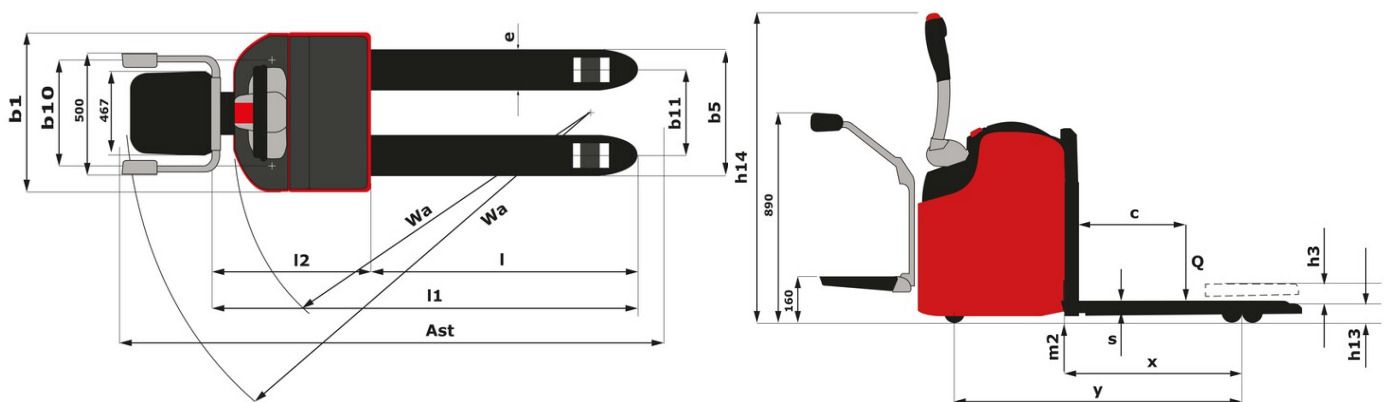



 **MANITOU**
HANDLING YOUR WORLD

Oficina Central

B.P. 249 - 430 rue de l'Aubinière

44150 Ancenis Cedex - Francia

Tel.: 00 33 (0)2 40 09 10 11 - Fax: 00 33 (0)2 40 09 10 97

www.manitou.com



Esta publicación describe las versiones y posibilidades de configuración de los productos Manitou que puedan diferir en equipamiento. Los equipamientos presentados en este folleto pueden ser de serie, opcionales o no estar disponibles en algunas versiones. Manitou se reserva el derecho, en cualquier momento y sin previo aviso, de modificar las especificaciones descritas y representadas. Las especificaciones aportadas no comprometen al fabricante. Para más información, póngase en contacto con su concesionario Manitou. Documento no contractual. Presentación de los productos no contractual. Lista de especificaciones no exhaustiva. Los logos y la identidad visual de la empresa son propiedad de Manitou y no pueden ser utilizados sin autorización. Todos los derechos reservados. Las fotos y los esquemas contenidos en este folleto se ofrecen para consulta y a título indicativo solamente.

Manitou BF SA - Sociedad anónima con Consejo de Administración - Capital social: 39 668 399 euros - 857 802 508 RCS Nantes