

Ficha técnica :

ER 16



 **MANITOU**
HANDLING YOUR WORLD

Technical characteristics			Métrico
1.1	Manufacturer		MANITOU
1.2	Model Name		ER 16
1.3	Power source		Electrical
1.4	Operator type		Seated
1.5	Max. capacity	Q	1600 kg
1.6	Load center of gravity	c	600 mm
1.8	Load distance, centre of drive axle to fork	x	439 mm
1.9	Wheelbase	y	1448 mm
Weight			
2.1	Service weight		3190 kg
Wheels			
3.1	Tires type		Vulkollan
3.5.2	Number of drive wheels - Size of drive wheels		1 x 355 x 155
3.3	Number of load wheels - Size of load wheels		2 x 282*105
3.5	Number of front wheels / rear wheels		1 / 2
3.6	Front wheel gauge	b10	0 mm
3.7	Rear wheel gauge	b11	1130 mm
Dimensions			
4.7	Height of overhead guard (cabin)	h6	2205 mm
4.8	Seat height/stand height	h7	1077 mm
4.19	Overall length	l1	2379 mm
4.20	Length to face of forks	l2	1229 mm
4.21	Overall width	b1	1270 mm
4.22	Forks section / width / length	s / e / l	40 mm x 100 mm / 1150 mm
4.23	Fork carriage ISO 2328 (class/form) A/B		2A
4.26	Distance between wheel arms/loading surfaces	b4	912 mm
4.25.1	Width over forks min. / max.	b5	316 mm / 697 mm
4.32	Ground clearance at centre of wheelbase	m2	70 mm
4.33	Aisle width for 1000 x 1200 pallet lengthways		2689 mm
4.34	Aisle width for 800 x 1200 pallet lengthways	Ast	2728 mm
4.35	Turning radius	Wa	1668 mm
Performances			
5.1	Travel speed (laden / unladen)		14.30 km/h / 14.50 km/h
5.2	Lifting speed (laden / unladen)		0.49 m/s / 0.80 m/s
5.3	Lowering speed (laden / unladen)		0.49 m/s / 0.48 m/s
5.4.1	Reach speed (with load / without load)		0.20 m/s / 0.20 m/s
5.7	Gradeability (laden / unladen)		8.50 % / 11.10 %
5.10	Service brake		Electric
Engine			
6.1	Drive motor rating S2 60 min		7.20 kW
6.2	Lift motor rating at S3 15%		15 kW
6.3	Battery according to DIN 43531/35/36 A, B, C		DIN 43531 C
6.4	Battery voltage / capacity		48 V / 465 Ah
6.5	Battery weight (+/- 5%)		735 kg
Miscellaneous			
8.1	Type of drive control		Electronic
8.3	Oil flow rate for attachments		25 l/min
8.4	Sound level at the driver's ear according to DIN 12 053		60.80 dB

ER 16 - Diagrama dimensional

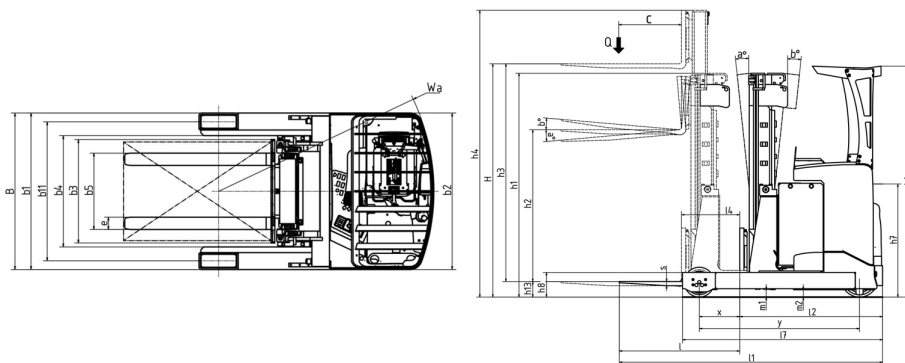

Características de los mástiles y capacidad residual

Free Lift Triplex (FLT)		FLT 48	FLT 54	FLT 63	FLT 68	FLT 73	FLT 80	FLT 85	FLT 90
α - Mast/fork carriage tilt, forward	°	3	3	3	3	3	3	3	3
β - Mast/fork carriage tilt, backward	°	1	1	1	1	1	1	1	1
h1 - Mast lowered height	mm	2140	2340	2640	2790	2957	3190	3673	3823
h2 - Mast free lift	mm	1600	1800	1900	2100	2400	2650	3100	3200
h3 - Mast lifting height	mm	4800	5400	6300	6750	7250	7950	8450	8950
h4 - Mast extended height	mm	5380	5980	6880	7330	7830	8530	9080	9530
Residual capacity with integrated side shift at max height	kg	1600	1600	1400	1100				

**Oficina Central**

B.P. 249 - 430 rue de l'Aubinière

44150 Ancenis Cedex - Francia

Tel.: 00 33 (0)2 40 09 10 11 - Fax: 00 33 (0)2 40 09 10 97

www.manitou.com

Esta publicación describe las versiones y posibilidades de configuración de los productos Manitou que puedan diferir en equipamiento. Los equipamientos presentados en este folleto pueden ser de serie, opcionales o no estar disponibles en algunas versiones. Manitou se reserva el derecho, en cualquier momento y sin previo aviso, de modificar las especificaciones descritas y representadas. Las especificaciones aportadas no comprometen al fabricante. Para más información, póngase en contacto con su concesionario Manitou. Documento no contractual. Presentación de los productos no contractual. Lista de especificaciones no exhaustiva. Los logos y la identidad visual de la empresa son propiedad de Manitou y no pueden ser utilizados sin autorización. Todos los derechos reservados. Las fotos y los esquemas contenidos en este folleto se ofrecen para consulta y a título indicativo solamente.

Manitou BF SA - Sociedad anónima con Consejo de Administración - Capital social: 39 668 399 euros - 857 802 508 RCS Nantes