

Technische fiche :

# ER 20



 **MANITOU**  
HANDLING YOUR WORLD

Technical characteristics		Metrisch	
1.1	Manufacturer		MANITOU
1.2	Model Name		ER 20
1.3	Power source		Electrical
1.4	Operator type		Seated
1.5	Max. capacity	Q	2000 kg
1.6	Load center of gravity	c	600 mm
1.8	Load distance, centre of drive axle to fork	x	441 mm
1.9	Wheelbase	y	1530 mm
<b>Weight</b>			
2.1	Service weight		3740 kg
<b>Wheels</b>			
3.1	Tires type		Vulkollan
3.5.2	Number of drive wheels - Size of drive wheels		1 x 355 x 155
3.3	Number of load wheels - Size of load wheels		2 x 28*105
3.5	Number of front wheels / rear wheels		1 / 2
3.6	Front wheel gauge	b10	0 mm
3.7	Rear wheel gauge	b11	1128 mm
<b>Dimensions</b>			
4.7	Height of overhead guard (cabin)	h6	2205 mm
4.8	Seat height/stand height	h7	1077 mm
4.19	Overall length	l1	2460 mm
4.20	Length to face of forks	l2	1310 mm
4.21	Overall width	b1	1270 mm
4.22	Forks section / width / length	s / e / l	40 mm x 100 mm / 1150 mm
4.23	Fork carriage ISO 2328 (class/form) A/B		2A
4.26	Distance between wheel arms/loading surfaces	b4	903 mm
4.25.1	Width over forks min. / max.	b5	316 mm / 697 mm
4.32	Ground clearance at centre of wheelbase	m2	70 mm
4.33	Aisle width for 1000 x 1200 pallet lengthways		2770 mm
4.34	Aisle width for 800 x 1200 pallet lengthways	Ast	2820 mm
4.35	Turning radius	Wa	1750 mm
<b>Performances</b>			
5.1	Travel speed (laden / unladen)		14.30 km/h / 14.50 km/h
5.2	Lifting speed (laden / unladen)		0.37 m/s / 0.63 m/s
5.3	Lowering speed (laden / unladen)		0.55 m/s / 0.43 m/s
5.4.1	Reach speed (with load / without load)		0.20 m/s / 0.20 m/s
5.7	Gradeability (laden / unladen)		6.90 % / 10.20 %
5.10	Service brake		Electric
<b>Engine</b>			
6.1	Drive motor rating S2 60 min		7.20 kW
6.2	Lift motor rating at S3 15%		15 kW
6.3	Battery according to DIN 43531/35/36 A, B, C		DIN 43531 C
6.4	Battery voltage / capacity		48 V / 620 Ah
6.5	Battery weight (+/- 5%)		920 kg
<b>Miscellaneous</b>			
8.1	Type of drive control		Electronic
8.3	Oil flow rate for attachments		25 l/min
8.4	Sound level at the driver's ear according to DIN 12 053		60.80 dB

ER 20 - Tekening met afmetingen

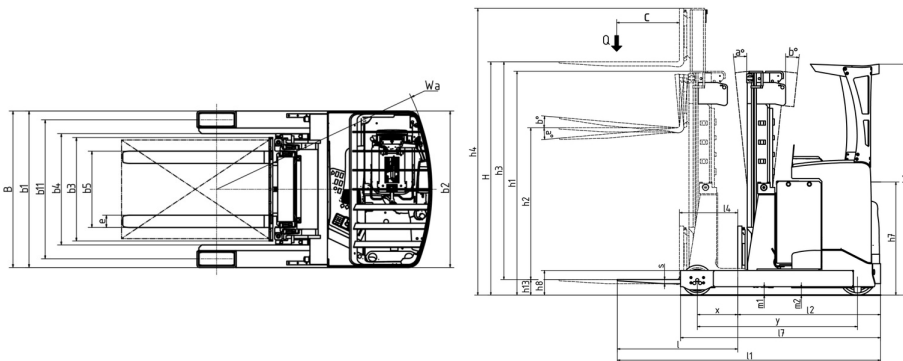

## Kenmerken van de masten en restcapaciteiten

Free Lift Triplex (FLT)		FLT 48	FLT 54	FLT 57	FLT 63	FLT 68	FLT 73	FLT 80	FLT 85	FLT 90
$\alpha$ - Mast/fork carriage tilt, forward	°	3	3	3	3	3	3	3	3	3
$\beta$ - Mast/fork carriage tilt, backward	°	1	1	1	1	1	1	1	1	1
h1 - Mast lowered height	mm	2140	2340	2640	2790	2957	3040	3190	3357	3523
h2 - Mast free lift	mm	16001	1800	1900	2100	2250	2400	2650	2800	2980
h3 - Mast lifting height	mm	4800	5400	5700	6300	6750	7250	7950	8450	8950
h4 - Mast extended height	mm	5380	5980	6880	7330	7830	8080	8530	9030	9530
Residual capacity with integrated side shift at max height	kg	2000	2000	2000	1850	1600				



**Hoofdkantoor**

B.P. 249 - 430 rue de l'Aubinière

44150 Ancenis Cedex - Frankrijk

Tel.: 00 33 (0)2 40 09 10 11 - Fax: 00 33 (0)2 40 09 10 97

[www.manitou.com](http://www.manitou.com)



Deze brochure beschrijft versies en configuratie-opties voor Manitou-producten die met verschillende apparatuur kunnen worden uitgerust. De uitrusting die in deze brochure wordt beschreven, kan standaard, optioneel of niet leverbaar zijn, afhankelijk van de uitvoering. Manitou behoudt zich het recht voor om de weergegeven en beschreven specificaties op elk moment en zonder kennisgeving vooraf te wijzigen. De fabrikant is niet aansprakelijk voor de gegeven specificaties. Neem voor meer informatie contact op met uw Manitou-dealer. Niet-contractueel document. De productbeschrijvingen kunnen afwijken van de werkelijke producten. De lijst met specificaties is niet allesomvattend. De logo's en visuele identiteit van het bedrijf zijn eigendom van Manitou en mogen niet zonder toestemming worden gebruikt. Alle rechten voorbehouden. De foto's en diagrammen in deze brochure zijn uitsluitend bedoeld voor raadpleging en informatie.

MANITOU BF SA - Naamloze vennootschap met raad van bestuur - Aandeelkapitaal: 39.668.399 euro - 857 802 508 RCS Nantes