

Ficha técnica :

ES 730



 **MANITOU**
HANDLING YOUR WORLD

Technical characteristics			Métrico
1.1	Manufacturer		MANITOU
1.2	Model Name		ES 730
1.3	Power source		Electrical
1.4	Operator type		Pedestrian
1.5	Max. capacity	Q	3000 kg
1.6	Load center of gravity	c	600 mm
1.8	Load distance, centre of drive axle to fork (low/raised) - Low position	x	655 mm
1.9	Wheelbase	y	1104 mm
Weight			
2.1	Service weight		1695 kg
Wheels			
3.1	Tires type		Polyurethane
3.5	Number of front wheels / rear wheels		3 / 4
3.5.2	Number of drive wheels		1
3.6	Front wheel gauge	b10	878 mm
3.7	Rear wheel gauge	b11	370 mm
Dimensions			
4.15	Fork height in low position	h13	90 mm
4.19	Overall length	l1	1920 mm
4.20	Length to face of forks	l2	771 mm
4.21	Overall width	b1	1080 mm
4.22	Forks section / width / length	s / e / l	80 mm / 210 mm / 1150 mm
4.31	Ground clearance below mast	m1	19 mm
4.33	Aisle Width for pallets 1000 x 1200 crossways	Ast	2487 mm
4.35	Turning radius	Wa	1595 mm
4.9	Height tiller min. / max.	h14 / h14	1030 mm / 1490 mm
Performances			
5.1	Travel speed (laden / unladen)		6 km/h / 6 km/h
5.10	Service brake		Electro magnetic
Engine			
6.1	Drive motor rating S2 60 min		2 kW
6.2	Lift motor rating at S3 15%		4 kW
6.3	Battery according to DIN 43531/35/36 A, B, C		DIN 43535-B
6.4	Battery voltage / capacity		24 V / 315 Ah
Miscellaneous			
8.1	Type of drive control		Variator
8.4	Sound level at the driver's ear according to DIN 12 053		70 dB

ES 730 - Diagrama dimensional

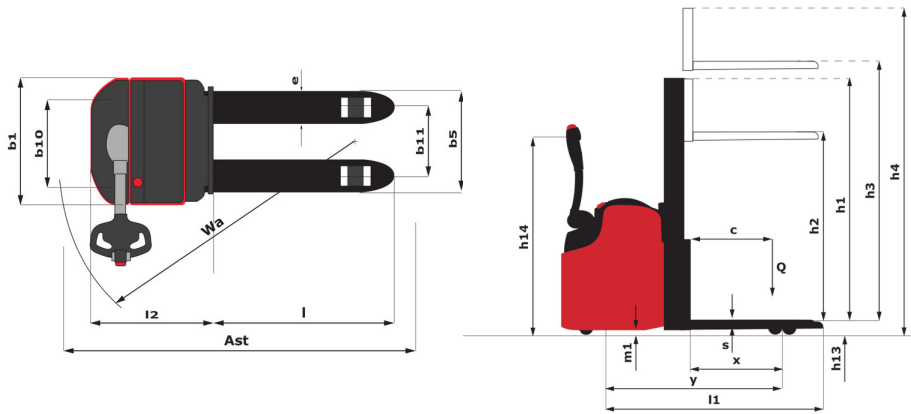

Características de los mástiles y capacidad residual

Visibilità totale Simplex (FVS)		FVS 14
h1 - Mast lowered height	mm	1930
h2 - Mast free lift	mm	1490
h3 - Mast lifting height	mm	1490
h4 - Mast extended height	mm	1930
Residual capacity at max height	kg	3000
Height at max capacity	mm	1490

Full Visibility Duplex (FVD)		FVD 27
h1 - Mast lowered height	mm	1900
h2 - Mast free lift	mm	77
h3 - Mast lifting height	mm	2700
h4 - Mast extended height	mm	3240
Residual capacity at max height	kg	3000
Height at max capacity	mm	2760



Oficina Central

B.P. 249 - 430 rue de l'Aubinière

44150 Ancenis Cedex - Francia

Tel.: 00 33 (0)2 40 09 10 11 - Fax: 00 33 (0)2 40 09 10 97

www.manitou.com



Esta publicación describe las versiones y posibilidades de configuración de los productos Manitou que puedan diferir en equipamiento. Los equipamientos presentados en este folleto pueden ser de serie, opcionales o no estar disponibles en algunas versiones. Manitou se reserva el derecho, en cualquier momento y sin previo aviso, de modificar las especificaciones descritas y representadas. Las especificaciones aportadas no comprometen al fabricante. Para más información, póngase en contacto con su concesionario Manitou. Documento no contractual. Presentación de los productos no contractual. Lista de especificaciones no exhaustiva. Los logos y la identidad visual de la empresa son propiedad de Manitou y no pueden ser utilizados sin autorización. Todos los derechos reservados. Las fotos y los esquemas contenidos en este folleto se ofrecen para consulta y a título indicativo solamente.

Manitou BF SA - Sociedad anónima con Consejo de Administración - Capital social: 39 668 399 euros - 857 802 508 RCS Nantes