

Ficha técnica :

# **MBL-X 900 90KL ST3**

---

Manitou is committed to bringing value to its backhoe loaders by incorporating advanced and robust features for multi-application capabilities. MBL X 900 is powered by Tier -II/III engine. The structure of MBL X 900 is durable and designed for intensive operations. It comes with the latest cabin design and unbreakable bonnet which promises to deliver higher up-time and require low maintenance, even after prolonged usage. Customers get quick returns on their investments on top of an optimum Total Cost of Ownership. It comes with an option of features such as AC, multipurpose bucket.



 **MANITOU**  
HANDLING YOUR WORLD

Capacities		Métrico
Wheelbase 2 wheels drive		2185 mm
Wheelbase 4 wheels drive		2130 mm
Weight and dimensions		
Unladen weight		7730 kg
Unladen weight with 4 WD		7730 kg
Unladen weight with 4 WD 7 in 1		8018 kg
Unladen weight 4WD - Center mount		7455 kg
Unladen weight 4WD - Side shift		7730 kg
Overall length	l1	7330 mm
Overall width	b1	2330 mm
Overall width with stabilizers extended - Center mount only		3910 mm
Cabin height	h6	2830 mm
Height of cab with air conditioning (option)	h6**	2860 mm
Overall height	h17	3790 mm
External turning radius over tyres (braked)	Wa1	3850 mm
External turning radius over tyres (unbraked)	Wa1	4200 mm
External turning radius over bucket (braked)	Wa5	5550 mm
External turning radius over bucket (unbraked)	Wa5	5700 mm
Standard tires front / rear		12.5 x 18 - 12 PR / 16.9 x 28-12PR
Optional tyre (front / rear)		9 x 16 - 16 PR / 14 x 25 - 20 PR
Reach at travelling	c2	2098 mm
Rear axle center to slew center	c3	1293 mm
Departure angle	a2	20 °
Angle of Approach	a3	66 °
Ground clearance	m4	280 mm
Performances		
Travel speed forward 1st / 2nd		5.40 km/h / 8.60 km/h
Travel speed forward 3rd / 4th		19.90 km/h / 40 km/h
Engine		
Engine brand		Kirloskar
Engine model		4R1040TA1 Turbo Charged Water Cooled BSIII
Displacement		4.15 l
Gross Power / Power		67.12 kW @ 2200 rpm
Max. torque		350 Nm
Battery voltage / capacity		12 V / 65 Ah
Transmission		
Transmission brand		Carraro
Number of gears (forward / reverse)		4 / 4
Torque converter stall ratio		2.64:1
Service brake		Wet disc brakes
Hydraulics		
Hydraulic flow		142 l/min
Main relief pressure		225 bar
Tank capacities		
Hydraulic oil		90 l
Liquid cooling tank volume		16 l
Fuel tank		145 l
Transmission oil		17.50 l
Engine oil		9.10 l
Oil rear axle		17.50 l
Bucket		
Backhoe standard capacity		0.24 m³
Width backhoe bucket		892 mm
Loader standard capacity		1 m³
Width loader bucket		2235 mm
Miscellaneous		
Power steering		Sí
Front steer axle of oscillation 2WD		20 °
Front steer axle of oscillation 4WD		16 °
Steering wheels (front / rear)		2 / 2

## Performance backhoe

	Standard dipper
p1 - Max dig depth (mm)	4741
r1 - Max reach ground level to slew center (mm)	5730
r2 - Max loading reach (mm)	1996
Max operating height (mm)	5626
Max loading height (mm)	3871
p2 - Max straight wall dig depth (mm)	2602
a10 - Max bucket rotation (°)	194
Total side shift (mm)	1198
Dipper tearout (kgF)	4336
Bucket tearout (kgF)	5810
Hydraulic lift capacity (kg)	1460

# Performance loader

Max dump angle (°)
h26 - Max operating height (loader version) (mm)
h23 - Max dump height at 45° (mm)
h24 - Max loadover height (mm)
h25 - Max hinge pin height (mm)
r3 - Max reach at full height 45° (mm)
p3 - Below ground dig depth (mm)
a13 - Rollback at ground (°)
Shovel breakout (kgf)
Arms breakout (kgF)
Lifting capacity at full height (kg)

Standard shovel	
	51
	4230
	2780
	3310
	3570
	710
	156
	45
	5229
	5312
	3819

## MBL-X 900 90KL ST3 - Diagrama dimensional

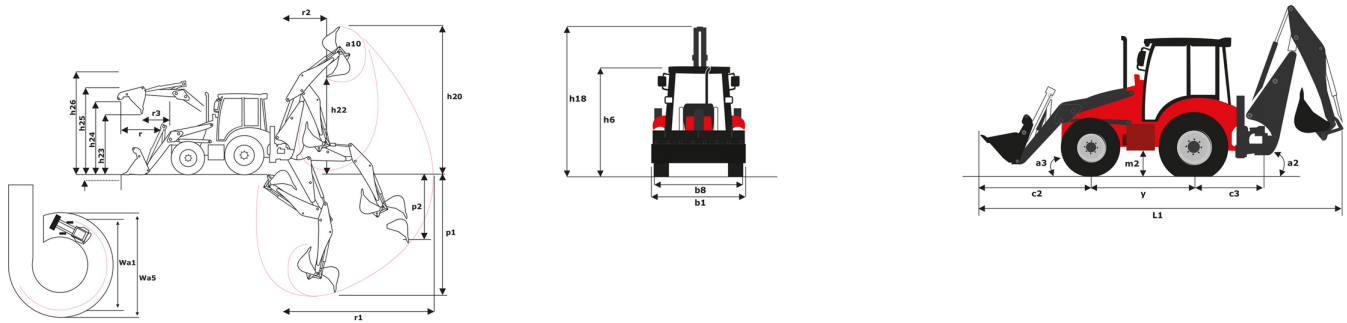



**Oficina Central**

B.P. 249 - 430 rue de l'Aubinière

44150 Ancenis Cedex - Francia

Tel.: 00 33 (0)2 40 09 10 11 - Fax: 00 33 (0)2 40 09 10 97

[www.manitou.com](http://www.manitou.com)



Esta publicación describe las versiones y posibilidades de configuración de los productos Manitou que puedan diferir en equipamiento. Los equipamientos presentados en este folleto pueden ser de serie, opcionales o no estar disponibles en algunas versiones. Manitou se reserva el derecho, en cualquier momento y sin previo aviso, de modificar las especificaciones descritas y representadas. Las especificaciones aportadas no comprometen al fabricante. Para más información, póngase en contacto con su concesionario Manitou. Documento no contractual. Presentación de los productos no contractual. Lista de especificaciones no exhaustiva. Los logos y la identidad visual de la empresa son propiedad de Manitou y no pueden ser utilizados sin autorización. Todos los derechos reservados. Las fotos y los esquemas contenidos en este folleto se ofrecen para consulta y a título indicativo solamente.

Manitou BF SA - Sociedad anónima con Consejo de Administración - Capital social: 39 668 399 euros - 857 802 508 RCS Nantes