

Ficha técnica :

# MC-X 30-2



 **MANITOU**  
HANDLING YOUR WORLD

Technical characteristics			Métrico
1.1	Manufacturer		Manitou
1.2	Model Name		MC-X_30-2
1.3	Power source		Diesel
1.4	Operator type		Seated
1.5	Max. capacity	Q	3000 kg
1.6	Load center of gravity	c	500 mm
1.8	Load distance, centre of drive axle to fork	x	626 mm
1.9	Wheelbase	y	1900 mm
Weight			
2.1	Service weight		4355 kg
2.2	Weight on front axle (laden) / rear axle (laden)		6435 kg / 920 kg
2.3	Weight on front axle (Unladen) / rear axle (Unladen)		1660 kg / 2695 kg
Wheels			
3.1	Tires type		Pneumatic
3.2	Dimensions of front wheels		12,5/80-18/12 SL R4
3.3	Dimensions of rear wheels		7,00-12/12 ED PLUS
3.5	Number of front wheels / rear wheels		2 / 2
3.5.2	Number of drive wheels		2
3.6	Front wheel gauge	b10	1159 mm
3.7	Rear wheel gauge	b11	1176 mm
Dimensions			
4.7	Height of overhead guard (cabin) / Overall height of low overhead guard (Buggie version)	h6 / h6*	2155 mm / 1990 mm
4.8	Seat height/stand height	h7	1094 mm
4.19	Overall length	l1	4265 mm
4.20	Length to face of forks	l2	3085 mm
4.21	Overall width	b1	1450 mm
4.22	Forks section x width x length	s / e / l	45 mm x 122 mm / 1150 mm
4.23	Fork carriage ISO 2328 (class/form) A/B		3A
4.24	Fork carriage width	b3	1260 mm
4.31	Ground clearance below mast	m1	300 mm
4.32	Ground clearance at centre of wheelbase	m2	310 mm
4.35	Turning radius	Wa	2650 mm
Performances			
5.1	Travel speed (laden / unladen)		12 km/h / 24.90 km/h
5.2	Lifting speed (laden / unladen)		0.47 m/s / 0.46 m/s
5.3	Lowering speed (laden / unladen)		0.50 m/s / 0.30 m/s
5.5	Drawbar pull (Laden / Unladen)		1810 daN / 1150 daN
5.7	Gradeability (laden / unladen)		23 % / 26 %
5.10	Service brake		Hydraulic brakes by loss of pressure
Engine			
7.2	I.C. Engine power rating		36 kW
7.1	Engine brand / model		Kubota / V2403
7.3	Rated speed		2700 rpm
7.4	Number of cylinders / Capacity of cylinders		4 - 2434 cm³
Miscellaneous			
8.1	Type of drive control		Cable
8.2	Working hydraulic pressure for attachments		180 bar
8.3	Oil flow rate for attachments		53 l/min
8.4	Sound level at the driver's ear according to DIN 12 053		82 dB

### MC-X 30-2 - Diagrama dimensional

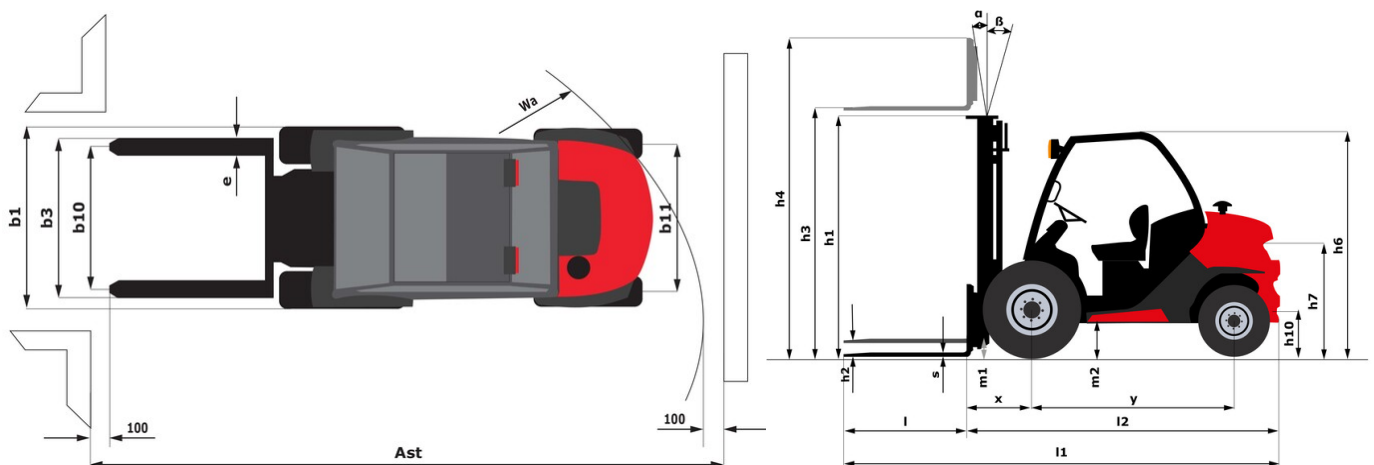

## Características de los mástiles y capacidad residual

Full Visibility Duplex (FVD)		FVD 45
α - Mast/fork carriage tilt, forward	°	10
β - Mast/fork carriage tilt, backward	°	12
h1 - Mast lowered height	mm	3038
h2 - Mast free lift	mm	117
h3 - Mast lifting height	mm	4500
h4 - Mast extended height	mm	5290
Height at max capacity	mm	2500

Free Lift Triplex (FLT)		FLT 34	FLT 37	FLT 40	FLT 43	FLT 47	FLT 55
α - Mast/fork carriage tilt, forward	°	10	10	10	10	10	6
β - Mast/fork carriage tilt, backward	°	12	12	12	12	12	6
h1 - Mast lowered height	mm	1988	1988	2188	2338	2438	2788
h2 - Mast free lift	mm	1235	1335	1435	1585	1685	2035
h3 - Mast lifting height	mm	3400	3700	4000	4300	4700	5500
h4 - Mast extended height	mm	4236	4536	4836	5136	5536	6336
Residual capacity at max height	kg	1580					
Height at max capacity	mm	2500	2500	2500	2500	2500	2500

Full Visibility Triplex (FVT)		FVD 33	FVD 37	FVT 33
α - Mast/fork carriage tilt, forward	°	10	10	10
β - Mast/fork carriage tilt, backward	°	12	12	12
h1 - Mast lowered height	mm	2338	2598	1878
h2 - Mast free lift	mm	117	117	129
h3 - Mast lifting height	mm	3300	3700	3300
h4 - Mast extended height	mm	4090	4490	4079
Height at max capacity	mm	2500	2500	2500



**Oficina Central**

B.P. 249 - 430 rue de l'Aubinière

44150 Ancenis Cedex - Francia

Tel.: 00 33 (0)2 40 09 10 11 - Fax: 00 33 (0)2 40 09 10 97

[www.manitou.com](http://www.manitou.com)



Esta publicación describe las versiones y posibilidades de configuración de los productos Manitou que puedan diferir en equipamiento. Los equipamientos presentados en este folleto pueden ser de serie, opcionales o no estar disponibles en algunas versiones. Manitou se reserva el derecho, en cualquier momento y sin previo aviso, de modificar las especificaciones descritas y representadas. Las especificaciones aportadas no comprometen al fabricante. Para más información, póngase en contacto con su concesionario Manitou. Documento no contractual. Presentación de los productos no contractual. Lista de especificaciones no exhaustiva. Los logos y la identidad visual de la empresa son propiedad de Manitou y no pueden ser utilizados sin autorización. Todos los derechos reservados. Las fotos y los esquemas contenidos en este folleto se ofrecen para consulta y a título indicativo solamente.

Manitou BF SA - Sociedad anónima con Consejo de Administración - Capital social: 39 668 399 euros - 857 802 508 RCS Nantes