

Ficha técnica :

MHT-X 10160 ST3A



 **MANITOU**
HANDLING YOUR WORLD

Capacities		Métrico
Max. capacity		16000 kg
Load center of gravity	c	600 mm
Max. lifting height		9.60 m
Max. outreach		5.20 m
Weight and dimensions		
Overall length	l1	7.35 m
Unladen weight (with forks)		21500 kg
Ground clearance	m4	0.43 m
Wheelbase	y	3.37 m
Length to face of forks	l2	6.15 m
Overall width	b1	2.48 m
Overall height	h17	2.99 m
Overall cab width	b4	0.95 m
Tilt-up angle	a4	12 °
Tilt-down angle	a5	104 °
External turning radius (over tyres)	Wa1	5.20 m
Forks length / width / section	l / e / s	1200 mm x 180 mm / 75 mm
Frame leveling corrector	a9	9 °
Wheels		
Standard tires		17,5-R25
Number of front wheels / rear wheels		2 / 2
Drive wheels (front / rear)		2 / 2
Steering mode		2 wheel steer, 4 wheel steer, Crab mode
Engine		
Engine brand		Yanmar
Engine nom		Stage IIIA
Engine model		4TN107TF-6SMU1
Number of cylinders / Capacity of cylinders		4 - 4567 cm³
I.C. Engine power rating / Power		173 Hp / 127 kW
Max. torque / Engine rotation		805 Nm@1500 rpm
Engine cooling system		Water
Number of batteries		2
Battery voltage		12 V
Drawbar pull		11770 daN
Transmission		
Transmission type		Hydrostatic
Number of gears (forward / reverse)		2 / 2
Max. travel speed		30 km/h
Parking brake		Automatic negative parking brake
Service brake		Oil-immersed multi-discs braking on front & rear axles
Gradeability (laden / unladen)		32.40 % / 55.40 %
Hydraulics		
Hydraulic pump type		Variable displacement pump
Hydraulic flow - Pressure		185 l/min - 350 bar
Tank capacities		
Engine oil		13 l
Fuel tank		315 l
Noise and vibration		
Noise to environment (LwA)		108 dB
Vibration on hands/arms		< 2.50 m/s²
Noise at driving position (LpA) tested following NF EN 12053 nom		75 dB
Miscellaneous		
Safety cab homologation		Cabin ROPS - FOPS level 2
Controls		JSM
Attachment recognition system (E-Reco)		Standard

MHT-X 10160 ST3A - Diagrama dimensional

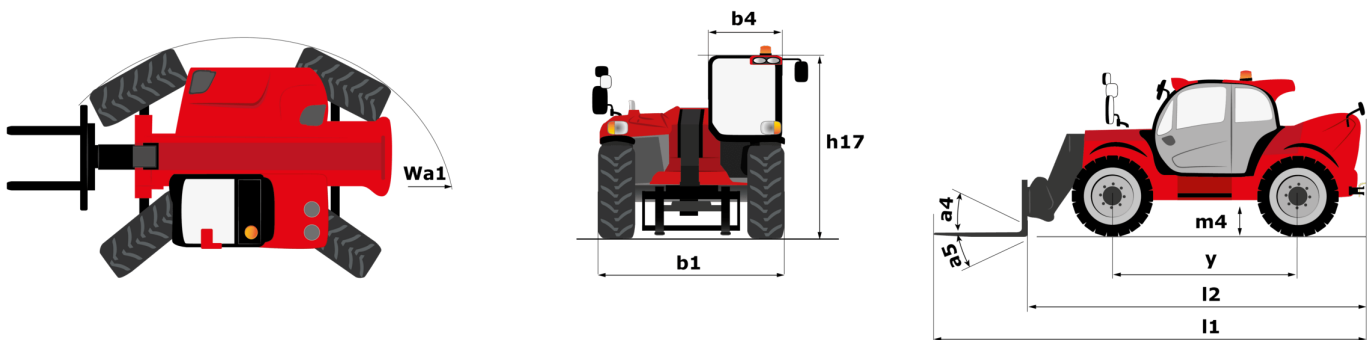

MHT-X 10160 ST3A - Diagramas de carga

Machine on tires with forks LC 600 mm Metric

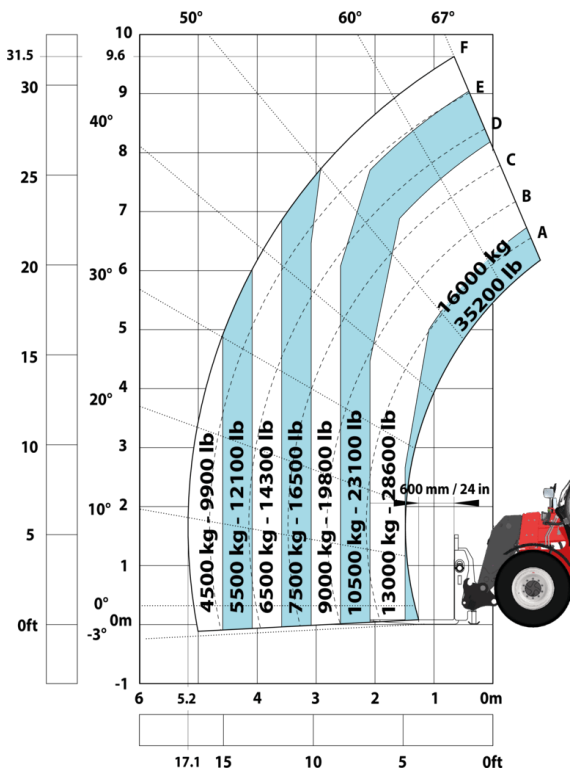

Machine on tires with forks LC 1200 mm Metric

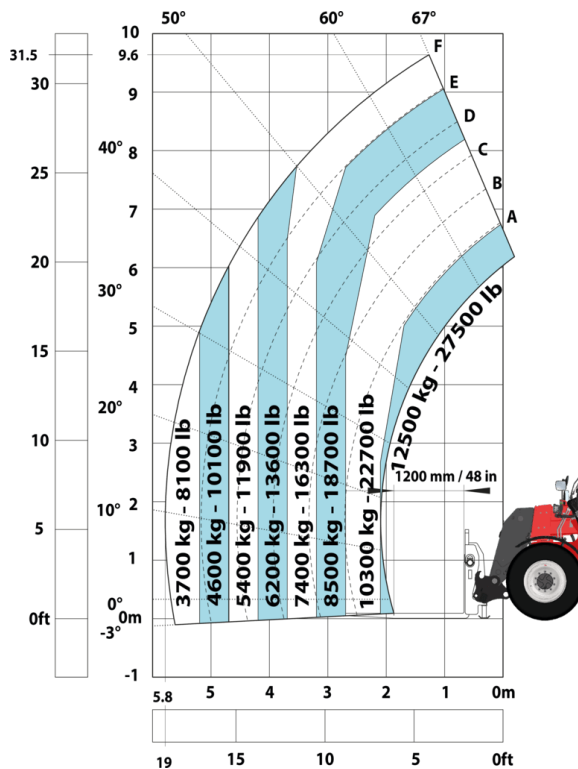

Machine on tires with 3-hook jib 16000 kg (Metric)

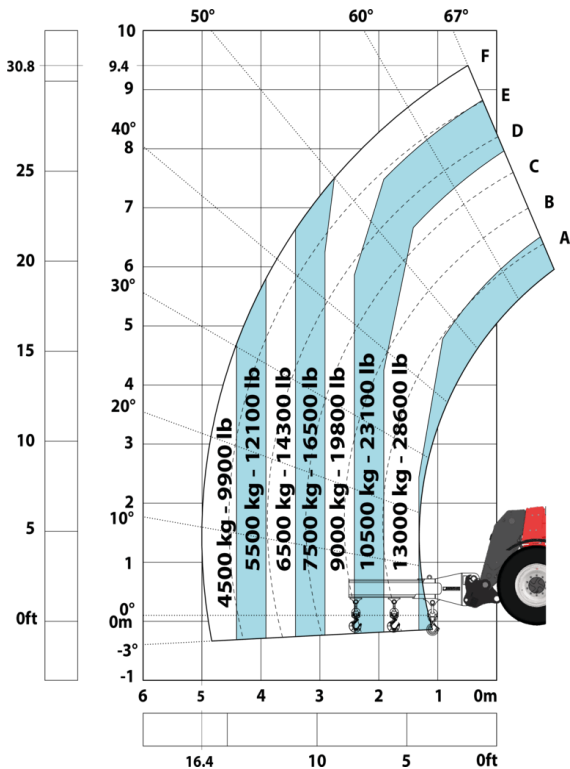

Machine on tires with platform Metric

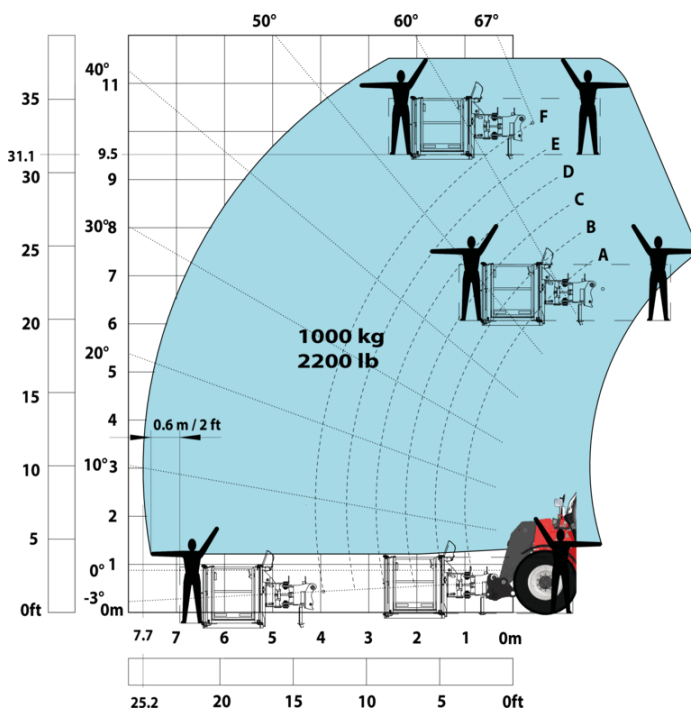

Machine on tires with tire handler TH 51 (Metric)



Machine on tires with cylinder handler CH 4 (Metric)





 **MANITOU**
HANDLING YOUR WORLD

Oficina Central

B.P. 249 - 430 rue de l'Aubinière

44150 Ancenis Cedex - Francia

Tel.: 00 33 (0)2 40 09 10 11 - Fax: 00 33 (0)2 40 09 10 97

www.manitou.com



Esta publicación describe las versiones y posibilidades de configuración de los productos Manitou que puedan diferir en equipamiento. Los equipamientos presentados en este folleto pueden ser de serie, opcionales o no estar disponibles en algunas versiones. Manitou se reserva el derecho, en cualquier momento y sin previo aviso, de modificar las especificaciones descritas y representadas. Las especificaciones aportadas no comprometen al fabricante. Para más información, póngase en contacto con su concesionario Manitou. Documento no contractual. Presentación de los productos no contractual. Lista de especificaciones no exhaustiva. Los logos y la identidad visual de la empresa son propiedad de Manitou y no pueden ser utilizados sin autorización. Todos los derechos reservados. Las fotos y los esquemas contenidos en este folleto se ofrecen para consulta y a título indicativo solamente.

Manitou BF SA - Sociedad anónima con Consejo de Administración - Capital social: 39 668 399 euros - 857 802 508 RCS Nantes