

Technical sheet :

MI-X 35 D



 **MANITOU**
HANDLING YOUR WORLD

| Technical characteristics | | | Metric |
|---------------------------|---|-----------|--------------------------|
| 1.1 | Manufacturer | | MANITOU |
| 1.2 | Model Name | | MI-X 35 D |
| 1.3 | Power source | | Diesel |
| 1.4 | Operator type | | Seated |
| 1.5 | Max. capacity | Q | 3500 kg |
| 1.6 | Load center of gravity | c | 500 mm |
| 1.8 | Load distance, centre of drive axle to fork | x | 485 mm |
| 1.9 | Wheelbase | y | 1700 mm |
| Weight | | | |
| 2.1 | Service weight | | 4860 kg |
| 2.2 | Weight on front axle (laden) / rear axle (laden) | | 7360 kg / 1000 kg |
| 2.3 | Weight on front axle (Unladen) / rear axle (Unladen) | | 1825 kg / 3035 kg |
| Wheels | | | |
| 3.1 | Tires type | | Inflatable |
| 3.2 | Dimensions of front wheels | | 28-9-15 12 |
| 3.3 | Dimensions of rear wheels | | 6.50-10 10 |
| 3.5 | Number of front wheels / rear wheels | | 2 / 2 |
| 3.5.2 | Number of drive wheels | | 2 |
| 3.6 | Front wheel gauge | b10 | 1005 mm |
| 3.7 | Rear wheel gauge | b11 | 975 mm |
| Dimensions | | | |
| 4.7 | Height of overhead guard (cabin) | h6 | 2130 mm |
| 4.8 | Seat height/stand height | h7 | 1215 mm |
| 4.12 | Height of towing bar (coupling height) | h10 | 360 mm |
| 4.19 | Overall length | l1 | 3935 mm |
| 4.20 | Length to face of forks | l2 | 2785 mm |
| 4.21 | Overall width | b1 | 1225 mm |
| 4.21 | Overall width - Single wheels | b1 | 1225 mm |
| 4.22 | Forks section / width / length | s / e / l | 50 mm x 122 mm x 1150 mm |
| 4.23 | Fork carriage ISO 2328 (class/form) A/B | | 3A |
| 4.24 | Fork carriage width | b3 | 1100 mm |
| 4.31 | Ground clearance below mast | m1 | 130 mm |
| 4.32 | Ground clearance at centre of wheelbase | m2 | 200 mm |
| 4.33 | Aisle Width for pallets 1000 x 1200 crossways | Ast | 4195 mm |
| 4.34 | Aisle width for 800 x 1200 pallet lengthways | Ast | 4395 mm |
| 4.36 | Internal turning radius (over tyres) | b13 | 160 mm |
| Performances | | | |
| 5.1 | Travel speed (laden / unladen) | | 18 km/h-18.50 km/h |
| 5.2 | Lifting speed (laden / unladen) | | 0.39 m/s-0.40 m/s |
| 5.3 | Lowering speed (laden / unladen) | | 0.40 m/s-0.35 m/s |
| 5.5 | Drawbar pull (Laden / Unladen) | | 1830 daN / 1520 daN |
| 5.7 | Gradeability (laden / unladen) | | 18 % / 20 % |
| 5.10 | Service brake | | Hydraulic |
| Engine | | | |
| 7.1 | Engine brand / model | | Yanmar / 4TNV94L-BXPHZ |
| 7.2 | I.C. Engine power rating | | 35 kW |
| 7.3 | Rated speed | | 2400 rpm |
| 7.4 | Number of cylinders / Capacity of cylinders | | 4 - 3054 cm³ |
| Miscellaneous | | | |
| 8.2 | Working hydraulic pressure for attachments | | 160 bar |
| 8.3 | Oil flow rate for attachments | | 69 l/min |
| 8.4 | Measured/guaranteed mean noise level at the ear of the operator | | < 84 dB |
| 8.4 | Sound level at the driver's ear according to DIN 12 053 | | 84 dB |

MI-X 35 D - Dimensional drawing

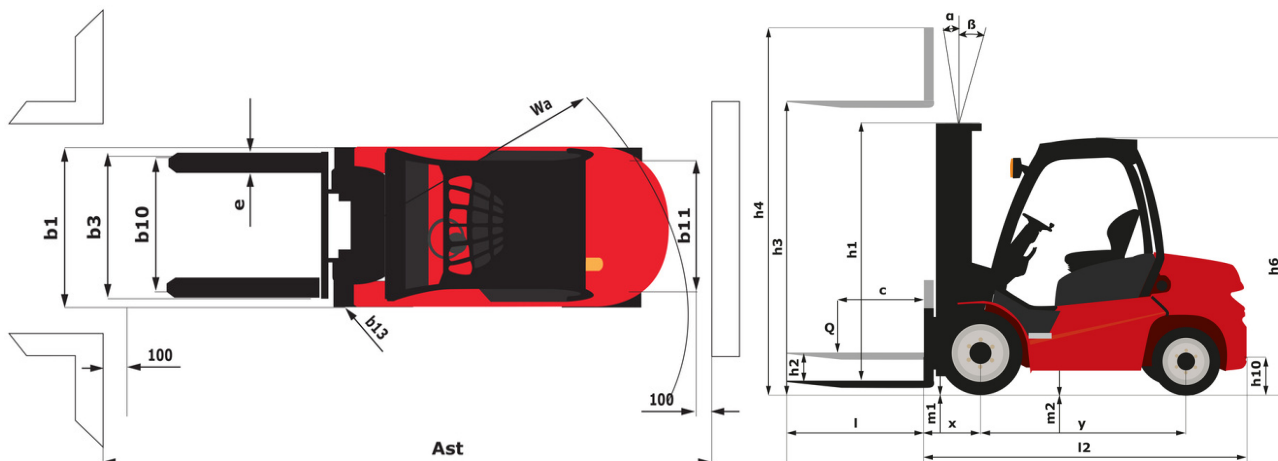

Characteristics of masts and residual capacities

| Full Visibility Duplex (FVD) | FVD 30 | FVD 33 | FVD 37 | FVD 40 | |
|--|--------|--------|--------|--------|------|
| α - Mast/fork carriage tilt, forward | ° | 6 | 6 | 6 | 6 |
| β - Mast/fork carriage tilt, backward | ° | 12 | 12 | 12 | 12 |
| h1 - Mast lowered height | mm | 2165 | 2315 | 2565 | 2715 |
| h2 - Mast free lift | mm | 145 | 145 | 145 | 145 |
| h3 - Mast lifting height | mm | 3000 | 3300 | 3700 | 4000 |
| h4 - Mast extended height | mm | 3815 | 4115 | 4515 | 4815 |
| Residual capacity at max height | kg | 3500 | 3500 | 3500 | 3500 |
| Residual capacity with integrated side shift at max height | kg | 3500 | 3500 | 3500 | 3500 |
| Height at max capacity | mm | 3000 | 3300 | 3700 | 4000 |
| Height at max capacity with integrated sideshift | mm | | 3300 | 3700 | 4000 |

| Free Lift Duplex (FLD) | FLD 33 | FLD 37 | FLD 40 | |
|--|--------|--------|--------|------|
| α - Mast/fork carriage tilt, forward | ° | 6 | 6 | 6 |
| β - Mast/fork carriage tilt, backward | ° | 12 | 12 | 12 |
| h1 - Mast lowered height | mm | 2330 | 2530 | 2680 |
| h2 - Mast free lift | mm | 1500 | 1700 | 1850 |
| h3 - Mast lifting height | mm | 3300 | 3700 | 4000 |
| h4 - Mast extended height | mm | 4130 | 4530 | 4830 |
| Residual capacity at max height | kg | 3500 | 3500 | 3500 |
| Residual capacity with integrated side shift at max height | kg | 3500 | 3500 | 3500 |
| Height at max capacity | mm | 3300 | 3700 | 4000 |
| Height at max capacity with integrated sideshift | mm | 3300 | 3700 | 4000 |

| Free Lift Triplex (FLT) | FLT 43 | FLT 45 | FLT 47 | FLT 48 | FLT 50 | FLT 55 | FLT 60 | FLT 65 |
|--|--------|--------|--------|--------|--------|--------|--------|--------|
| α - Mast/fork carriage tilt, forward | ° | 6 | 6 | 6 | 6 | 6 | 3 | 3 |
| β - Mast/fork carriage tilt, backward | ° | 6 | 6 | 6 | 6 | 6 | 6 | 6 |
| h1 - Mast lowered height | mm | 2215 | 2265 | 2315 | 2365 | 2415 | 2565 | 2815 |
| h2 - Mast free lift | mm | 1385 | 1435 | 1485 | 1535 | 1585 | 1735 | 1985 |
| h3 - Mast lifting height | mm | 4300 | 4500 | 4700 | 4800 | 5000 | 5500 | 6000 |
| h4 - Mast extended height | mm | 5130 | 5380 | 5530 | 5630 | 5830 | 6330 | 6880 |
| Residual capacity at max height | kg | 3450 | 3400 | 3300 | 3300 | 3000 | 2200 | 1600 |
| Residual capacity with integrated side shift at max height | kg | 3450 | 3300 | 3200 | 3200 | 2900 | 2100 | 1500 |
| Height at max capacity | mm | 4000 | 4000 | 4000 | 4000 | 4000 | 4000 | 4000 |
| Height at max capacity with integrated sideshift | mm | 4000 | 4000 | 4000 | | | | |



Head Office

B.P. 249 - 430 rue de l'Aubinière

44150 Ancenis Cedex - France

Tel: +33 (0)2 40 09 10 11 - Fax: +33 (0)2 40 09 10 97

www.manitou.com



This publication provides a description of the configuration versions and options for Manitou products, which may differ for equipment. The equipment presented in this brochure may be part of a series, as an option, or it may not be available, depending on the versions. Manitou reserves the right, at any time and without notice, to amend the specifications described and represented. The specifications provided do not bind the manufacturer. For more details, please contact your Manitou agent. This is not a contractually binding document. The presentation of the products is not contractually binding. List of specifications non-exhaustive. The logos as well as the visual identity of the company are owned by Manitou and cannot be used without authorisation. All rights reserved. The photos and diagrams contained in this brochure are only provided for consultation and information purposes.

MANITOU BF SA - Limited company with board of directors - Share capital: 39,668,399 euros - 857 802 508 RCS Nantes