

Technical sheet :

MLA 5-60 H-Z



 **MANITOU**
HANDLING YOUR WORLD

Capacities		Imperial
Static tipping load with bucket (straight)		4828 lb
Static tipping load with bucket (full turn)		3735 lb
Static tipping load with forks (straight)		3411 lb
Static tipping load with forks (full turn)		2654 lb
Max. height of bucket pivot point	h35	10 ft 4 in
Max. lifting height (below forks)	h3	9 ft 9 in
Reach at max. height		1 ft 5 in
Breakout force with bucket		4329.46 daN
Weight and dimensions		
Unladen weight (with forks) with 4-post canopy		7470 lb
Overall length to carriage (with hitch)	l11	13 ft 9 in
Wheelbase	y	69 in
Overall width of 4 posts canopy	b22	4 ft
Overall cab width	b4	4 ft
Overall height with 4 posts canopy	h38	7 ft 7 in
Overall height with cab	h17	7 ft 7 in
Tilt-up angle	a4	39.90 °
Tilt-down angle	a5	44.70 °
Articulation angle	a19	45 °
Overall width less bucket	b1	4 ft 10 in
Ground clearance	m4	10 in
Performances		
Crowd		2.52 s
Dump		1.85 s
Engine		
Engine brand		Deutz
Engine model		TD 2.2 L3
Engine norm		Stage V / Tier 4 Final
Number of cylinders / Capacity of cylinders		3 - 21 in³
I.C. Engine power rating / Power		60 Hp / 45.50 kW
Max. torque / Engine rotation		148 ft/lbs / 2400 rpm
Engine cooling system		2 radiators water + hydraulic oil
Transmission		
Transmission type		Hydrostatic
Number of gears (forward / reverse)		2 / 2
Max. travel speed (may vary according to applicable regulations)		18 mph
Differential lock		Front and rear locking of the machine
Parking brake		Manual
Service brake		Hydraulic drum brake on front axle, acting on all 4 wheels
Hydraulics		
Hydraulic pump type		Gear pump
Hydraulic flow - Pressure		15 US gpm / 3046 PSI
High-Flow Option (l/min)		19 US gpm
Drive hydraulic system pressure		6092 PSI
Tank capacities		
Hydraulic oil		12 US gal
Fuel tank		22 US gal
Miscellaneous		
Cab certification		ROPS - FOPS cab (level 1)

MLA 5-60 H-Z - Dimensional drawing

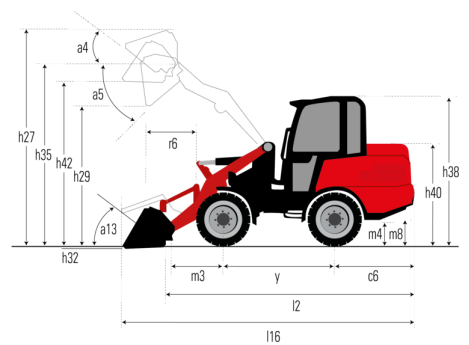
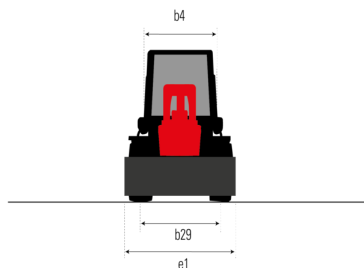
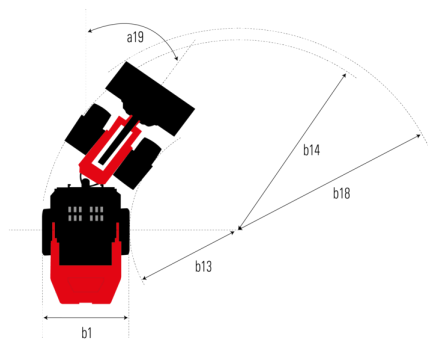



Head Office

B.P. 249 - 430 rue de l'Aubinière

44150 Ancenis Cedex - France

Tel: +33 (0)2 40 09 10 11 - Fax: +33 (0)2 40 09 10 97

www.manitou.com



This publication provides a description of the configuration versions and options for Manitou products, which may differ for equipment. The equipment presented in this brochure may be part of a series, as an option, or it may not be available, depending on the versions. Manitou reserves the right, at any time and without notice, to amend the specifications described and represented. The specifications provided do not bind the manufacturer. For more details, please contact your Manitou agent. This is not a contractually binding document. The presentation of the products is not contractually binding. List of specifications non-exhaustive. The logos as well as the visual identity of the company are owned by Manitou and cannot be used without authorisation. All rights reserved. The photos and diagrams contained in this brochure are only provided for consultation and information purposes.

MANITOU BF SA - Limited company with board of directors - Share capital: 39,668,399 euros - 857 802 508 RCS Nantes