

Technisches Datenblatt :

MRT 2145 115

VISION



 **MANITOU**
HANDLING YOUR WORLD

Capacities		Metrisch
Max. capacity		4500 kg
Max. lifting height		20.60 m
Max. outreach		18 m
Weight and dimensions		
Overall length (with forks)	l1	7.93 m
Length to face of forks	l2	6.73 m
Overall width	b1	2.48 m
Overall height	h17	3.04 m
Overall cab width	b4	0.96 m
Ground clearance	m4	0.37 m
Wheelbase	y	2.73 m
Tilt-up angle	a4	10 °
Tilt-down angle	a5	107 °
Turret rotation / rotation (Max.)		400 ° or 400 °
Overall weight		14900 kg
Forks length / width / section	l / e / s	1200 mm x 125 mm x 50 mm
Wheels		
Standard tires		18-19,5
Drive wheels (front / rear)		2 / 2
Steering mode		2 wheel steer, 4 wheel steer, Crab mode
Stabilisers		
Stabilizers Type		Spider Type
Controls with stabs		Stabs Commands Individual or Simultaneous
Engine		
Engine brand		Deutz
Engine nom		Stage V / Tier 4
Engine model		TCD 3.6 L4
I.C. Engine power rating / Power / Engine rotation		116 Hp / 85 kW @ 2200 rpm
Max. torque / Engine rotation (min)		460 Nm @ 1600 rpm
Number of cylinders - Capacity of cylinders		4 - 3620 cm³
Engine cooling system		Water cooled
Electric circuit		
Number of batteries / Battery voltage		2 x 12 V
12V Battery capacity		120 Ah
Battery starting current		(EN)850 A
Transmission		
Transmission type		Hydrostatic
Number of gears (forward / reverse)		2 / 2
Max. travel speed		40 km/h
Drawbar pull		9700 daN
Parking brake		Automatic negative parking brake
Service brake		Oil-immersed multi-discs braking on front & rear axles
Performances		
Gradeability (laden / unladen)		48.70 % / 49.80 %
Hydraulics		
Hydraulic pump type		Variable displacement pump
Hydraulic flow		116 l/min
Hydraulic Pressure		275 bar
Tank capacities		
Engine oil		11 l
Fuel tank		133 l
Diesel Exhaust fluid (AdBlue® type)		11 l
Noise and vibration		
Noise at driving position (LpA)		68 dB
Noise to environment (LwA)		106 dB
Vibration on hands/arms		< 2.50 m/s²
Miscellaneous		
Steering wheels (front / rear)		2 / 2
Controls		2 Joysticks
Safety cab homologation		Cabin ROPS - FOPS level 2
Attachment recognition system (E-Reco)		Standard

MRT 2145 115 - Maßzeichnung

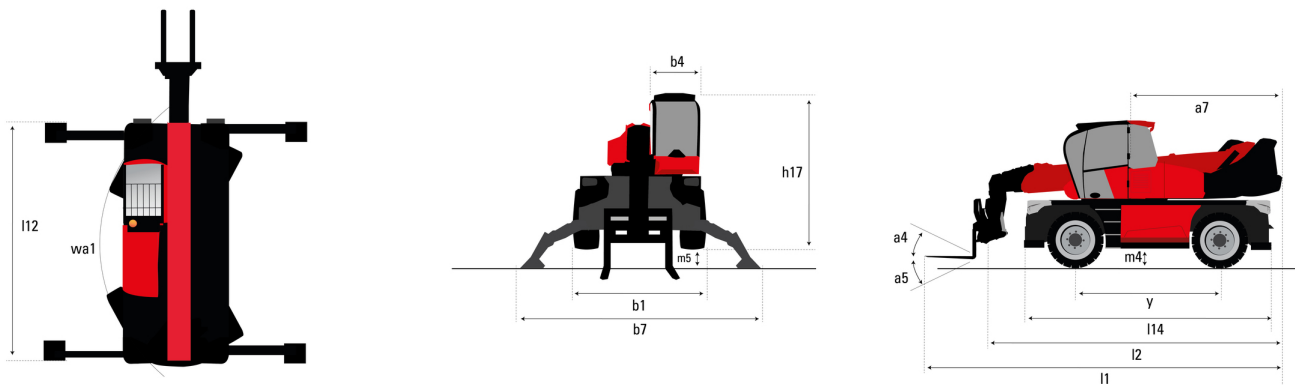

Sonstige Daten		Metrisch
Length of frame	$l14$	4.97 m
Wheelbase	y	2.73 m
Ground clearance	$m4$	0.37 m
Counterweight offset (turret at 90°)	$a7$	2.50 m
Tilt-up angle	$a4$	10 °
Tilt-down angle	$a5$	107 °
Overall length at stabilisers	$l12$	4.71 m
External turning radius (over tyres)	$Wa1$	4.16 m
Overall width with stabilisers extended	$b7$	4.98 m
Overall height	$h17$	3.04 m
Ground clearance under front tires on stabilizers	$m5$	0.18 m

MRT 2145 115 - Traglasttabellen

Machine on tires with forks Metric



Machine on lowered stabilisers with forks Metric

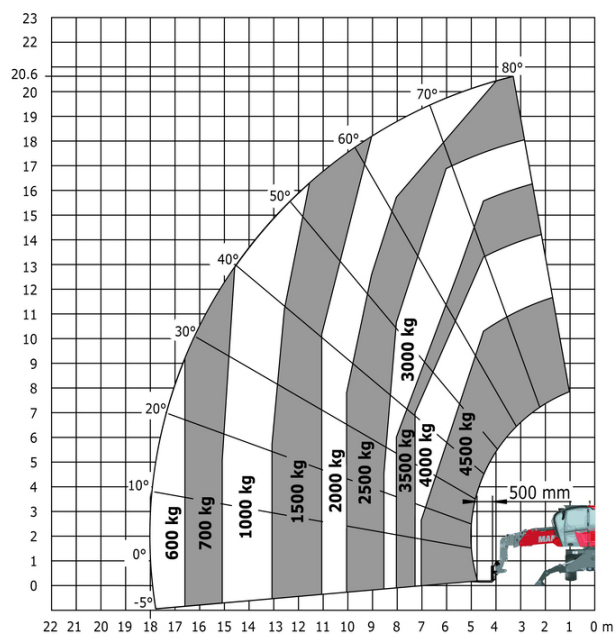

Machine on lowered stabilisers with winch 5000 kg Metric

Machine on lowered stabilisers with 4000 kg jib (Metric)

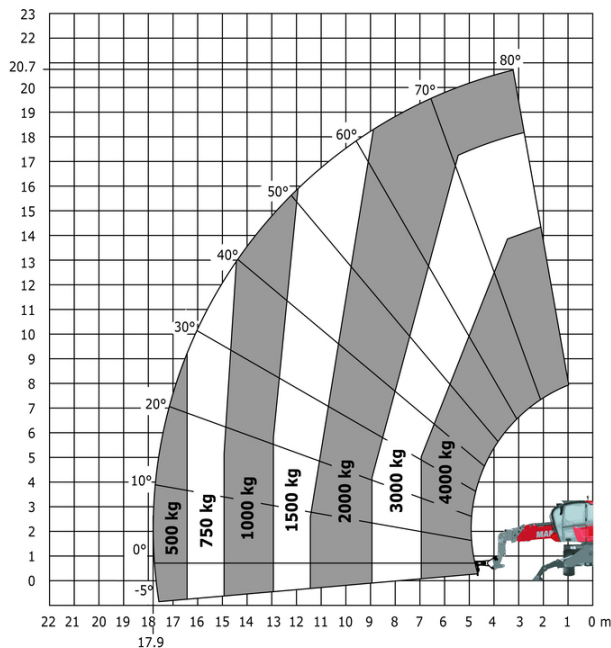
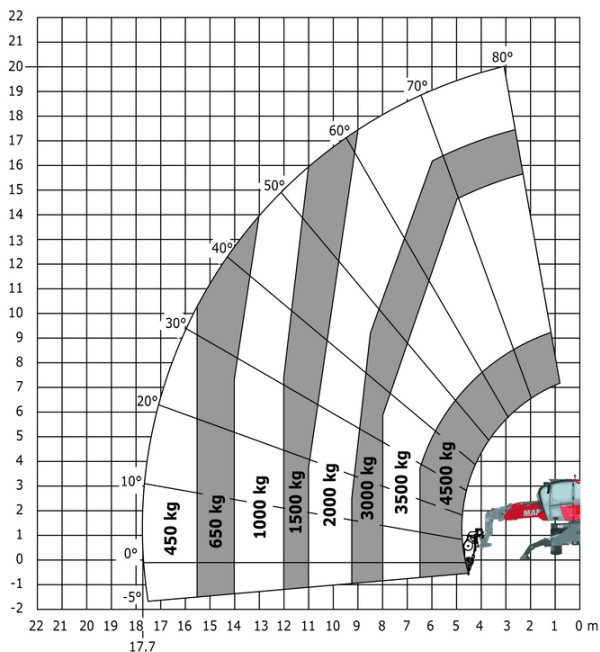

Machine on lowered stabilisers with 1500 kg jib with winch (Metric)

Machine on lowered stabilisers with hook 5000 kg (Metric)

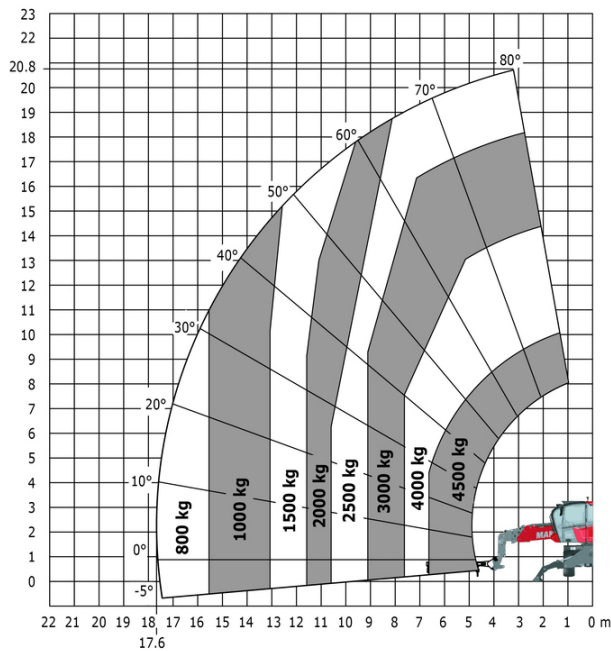

Machine on lowered stabilisers with 365 kg platform Metric Machine on lowered stabilisers with 1000 kg platform Metric

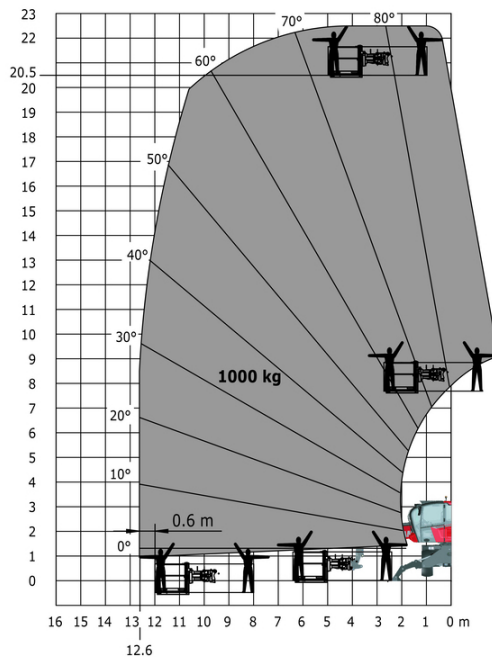
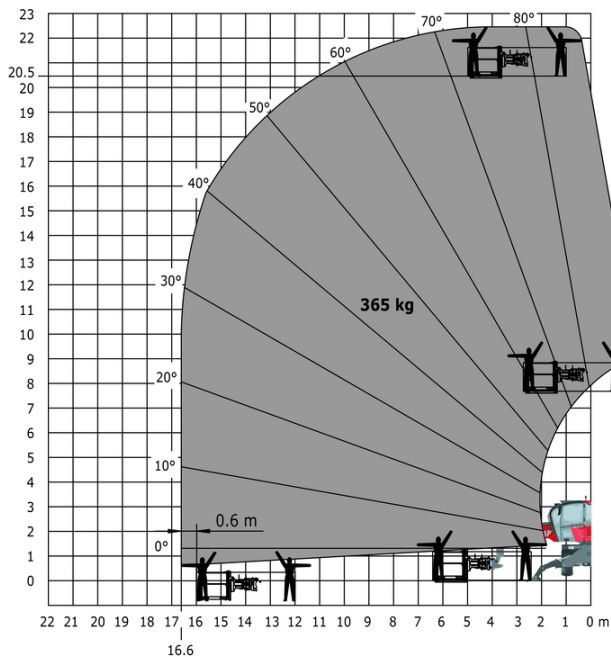



Hauptsitz

B.P. 249 - 430 rue de l'Aubinière

44150 Ancenis Cedex - France

Tel: +33 (0)2 40 09 10 11 - Fax: +33 (0)2 40 09 10 97

www.manitou.com



Diese Publikation enthält eine Beschreibung der Konfigurationsvarianten und Optionen für Manitou-Produkte, die je nach Ausstattung unterschiedlich sein können. Die in dieser Broschüre vorgestellten Ausstattungen können Teil einer Serie, als Option erhältlich oder je nach Ausführung nicht verfügbar sein. Manitou behält sich das Recht vor, die beschriebenen und dargestellten Spezifikationen jederzeit und ohne Vorankündigung zu ändern. Die angegebenen Spezifikationen sind für den Hersteller nicht bindend. Für weitere Einzelheiten wenden Sie sich bitte an Ihren Manitou-Händler. Es handelt sich nicht um ein vertraglich bindendes Dokument. Die Darstellung der Produkte ist vertraglich nicht bindend. Die Liste der Spezifikationen ist nicht vollständig. Die Logos sowie die visuelle Identität des Unternehmens sind Eigentum von Manitou und dürfen nicht ohne Genehmigung verwendet werden. Alle Rechte vorbehalten. Die in dieser Broschüre enthaltenen Fotos und Diagramme werden nur zu Anschauungs- und Informationszwecken zur Verfügung gestellt.

MANITOU BF SA - Gesellschaft mit beschränkter Haftung mit Verwaltungsrat - Aktienkapital: 39 668 399 Euro - 857 802 508 RCS Nantes