

Ficha técnica :

MRT 2660

VISION +



 **MANITOU**
HANDLING YOUR WORLD

| Capacities | | Métrico |
|---|-----------|--|
| Max. capacity | | 6000 kg |
| Max. lifting height | | 25.90 m |
| Max. outreach | | 21.70 m |
| Weight and dimensions | | |
| Overall length (with forks) | l1 | 9.28 m |
| Length to face of forks | l2 | 8.08 m |
| Overall width | b1 | 2.50 m |
| Overall height | h17 | 3.10 m |
| Overall cab width | b4 | 0.96 m |
| Ground clearance | m4 | 0.38 m |
| Wheelbase | y | 3.05 m |
| Tilt-up angle | a4 | 12 ° |
| Tilt-down angle | a5 | 110 ° |
| Turret rotation | | 360 ° |
| Overall weight | | 18000 kg |
| Forks length / width / section | l / e / s | 1200 mm x 100 mm x 60 mm |
| Wheels | | |
| Standard tires | | 445/65 R22,5 |
| Drive wheels (front / rear) | | 2 / 2 |
| Steering mode | | 2 wheel steer, 4 wheel steer, Crab mode |
| Stabilisers | | |
| Stabilizers Type | | Telescopic Duplex |
| Controls with stabs | | Stabs Commands Individual or Simultaneous |
| Engine | | |
| Engine brand | | Yanmar |
| Engine nom | | Stage V / Tier 4 |
| Engine model | | 4TN107FHT-6SMU1 |
| I.C. Engine power rating / Power | | 156 Hp / 115 kW |
| Max. torque / Engine rotation (min) | | 602 Nm @ 1500 rpm |
| Number of cylinders - Capacity of cylinders | | 4 - 4567 cm³ |
| Engine cooling system | | Water cooled |
| Electric circuit | | |
| Number of batteries / Battery voltage | | 2 x 12 V |
| 12V Battery capacity | | 120 Ah |
| Battery starting current | | (EN)850 A |
| Transmission | | |
| Transmission type | | Hydrostatic |
| Gearbox / Number of gears (forward) / Number of gears (reverse) | | Speedshift / 2 / 2 |
| Max. travel speed | | 40 km/h |
| Drawbar pull | | 8600 daN |
| Parking brake | | Automatic negative parking brake |
| Service brake | | Oil-immersed multi-discs braking on front & rear axles |
| Performances | | |
| Gradeability (laden / unladen) | | 40.40 % / 45.50 % |
| Hydraulics | | |
| Hydraulic pump type | | Variable displacement pump |
| Hydraulic flow | | 172 l/min |
| Hydraulic Pressure | | 350 bar |
| Tank capacities | | |
| Engine oil | | 13 l |
| Fuel tank | | 270 l |
| Diesel Exhaust fluid (AdBlue® type) | | 24 l |
| Noise and vibration | | |
| Noise at driving position (LpA) | | 68 dB |
| Noise to environment (LwA) | | 108 dB |
| Vibration on hands/arms | | < 2.50 m/s² |
| Miscellaneous | | |
| Steering wheels (front / rear) | | 2 / 2 |
| Controls | | 2 Joysticks |
| Safety cab homologation | | Cabin ROPS - FOPS level 2 |
| Attachment recognition system (E-Reco) | | Standard |

MRT 2660 - Diagrama dimensional

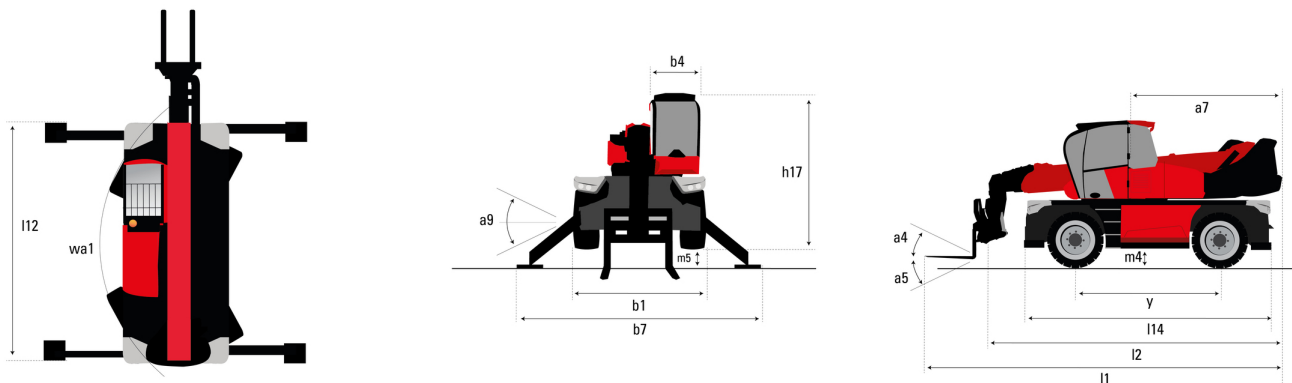

| Otros datos | | Métrico |
|---|-----|---------|
| Length of frame | l14 | 5.69 m |
| Wheelbase | y | 3.05 m |
| Ground clearance | m4 | 0.38 m |
| Counterweight offset (turret at 90°) | a7 | 3.37 m |
| Tilt-up angle | a4 | 12 ° |
| Tilt-down angle | a5 | 110 ° |
| Overall length at stabilisers | l12 | 5.30 m |
| External turning radius (over tyres) | Wa1 | 4.46 m |
| Overall width with stabilisers extended | b7 | 5.79 m |
| Overall height | h17 | 3.10 m |
| Frame leveling corrector | a9 | +/- 7 ° |
| Ground clearance under front tires on stabilizers | m5 | 0.38 m |

MRT 2660 - Diagramas de carga

Machine on tires with forks Metric

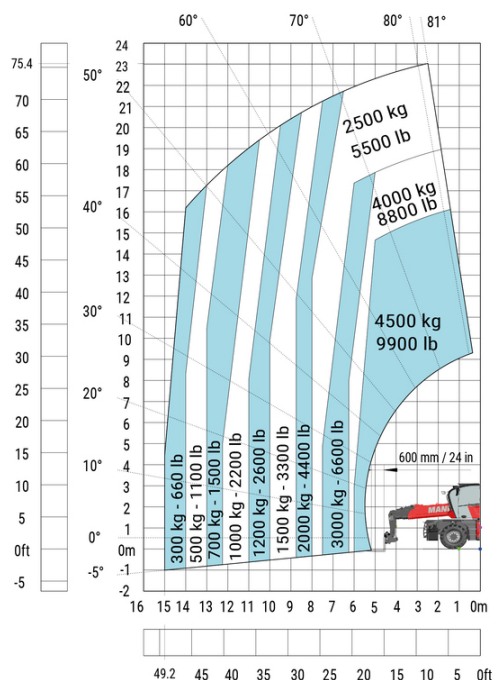

Machine on lowered stabilisers with forks (CAF) Metric

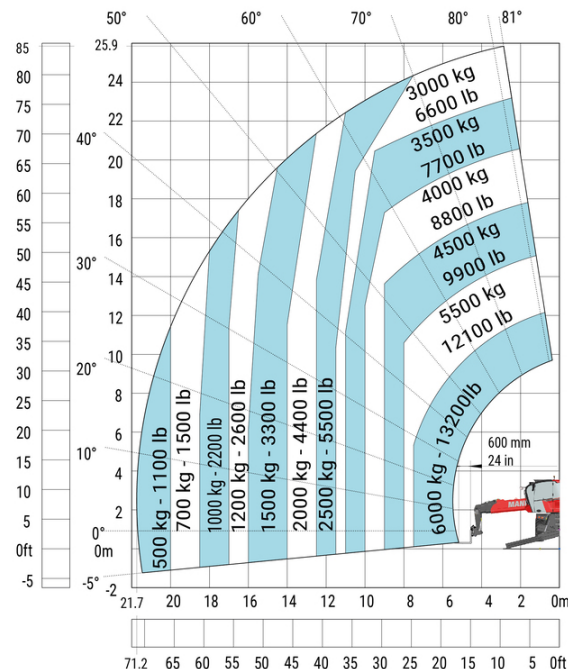

Machine on lowered stabilisers with winch 6000 kg (Metric) Machine on lowered stabilisers with 1500 kg jib with winch (Metric)

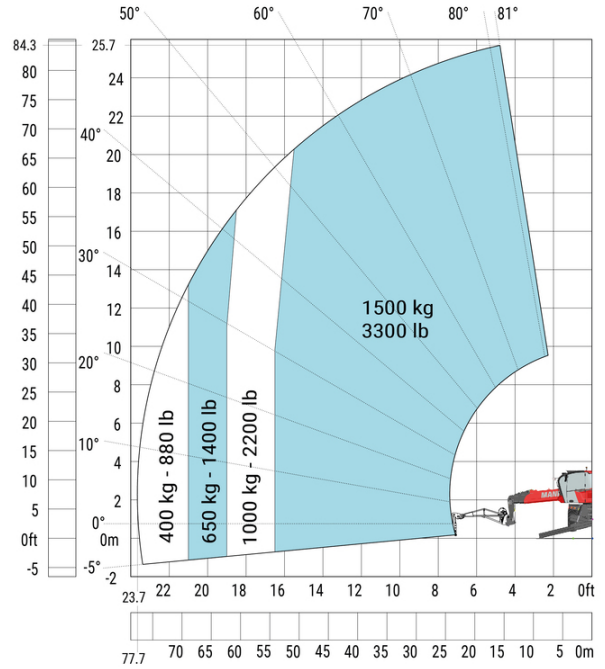

Machine on lowered stabilisers with extensible jib with winch (Metric)

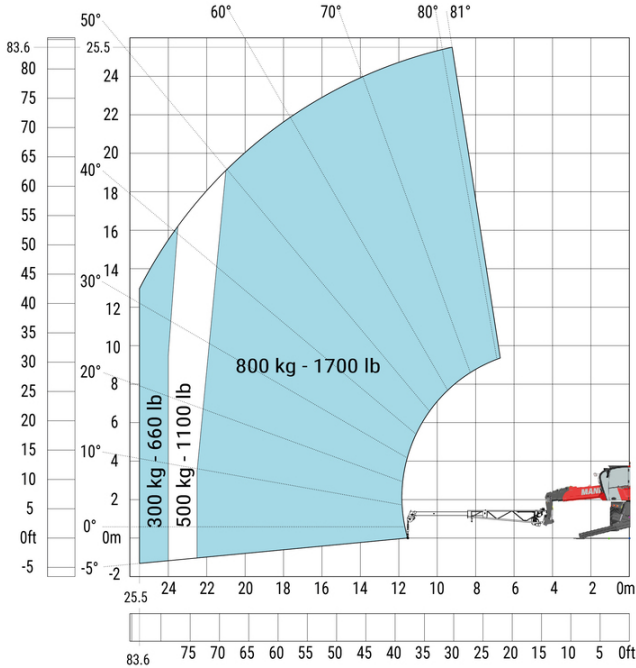

Machine on lowered stabilisers with hook 6000 kg (Metric)



Machine on lowered stabilisers with 365 kg platform Metric Machine on lowered stabilisers with 1000 kg platform Metric

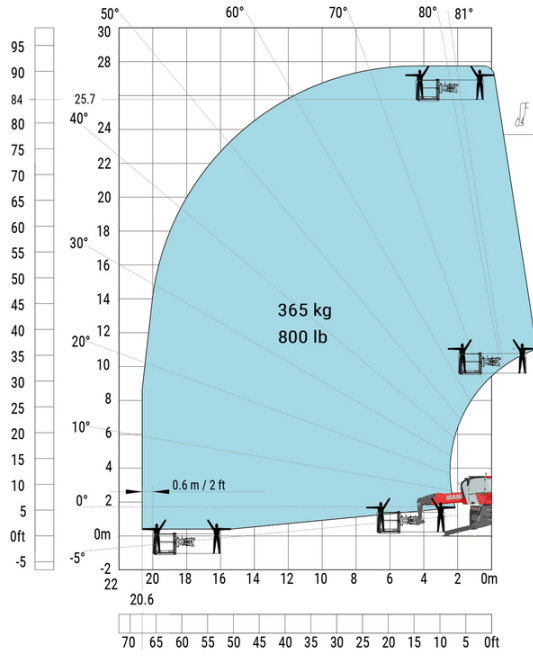

Machine on lowered stabilisers with 3D positive Metric

Machine on lowered stabilisers with 3D positive / negative Metric

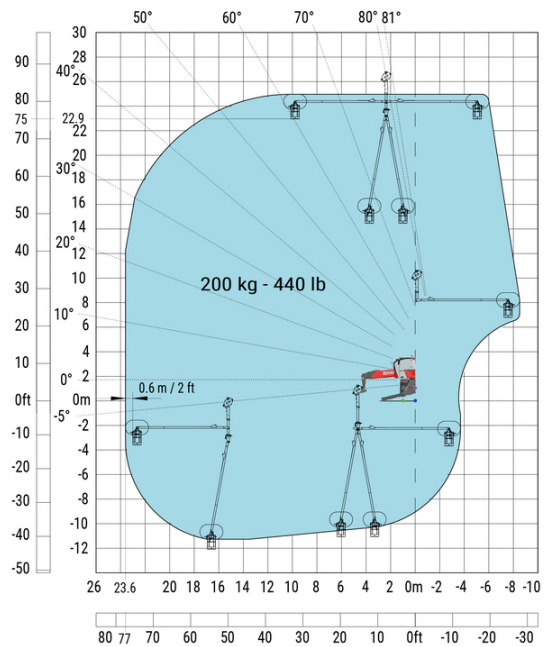



Oficina Central

B.P. 249 - 430 rue de l'Aubinière

44150 Ancenis Cedex - Francia

Tel.: 00 33 (0)2 40 09 10 11 - Fax: 00 33 (0)2 40 09 10 97

www.manitou.com



Esta publicación describe las versiones y posibilidades de configuración de los productos Manitou que puedan diferir en equipamiento. Los equipamientos presentados en este folleto pueden ser de serie, opcionales o no estar disponibles en algunas versiones. Manitou se reserva el derecho, en cualquier momento y sin previo aviso, de modificar las especificaciones descritas y representadas. Las especificaciones aportadas no comprometen al fabricante. Para más información, póngase en contacto con su concesionario Manitou. Documento no contractual. Presentación de los productos no contractual. Lista de especificaciones no exhaustiva. Los logos y la identidad visual de la empresa son propiedad de Manitou y no pueden ser utilizados sin autorización. Todos los derechos reservados. Las fotos y los esquemas contenidos en este folleto se ofrecen para consulta y a título indicativo solamente.

Manitou BF SA - Sociedad anónima con Consejo de Administración - Capital social: 39 668 399 euros - 857 802 508 RCS Nantes