

Ficha técnica :

MSI-X 30



 **MANITOU**
HANDLING YOUR WORLD

Technical characteristics		Métrico	
1.1	Manufacturer		Manitou
1.2	Model Name		MSI-X_30
1.3	Power source		Diesel
1.4	Operator type		Seated
1.5	Max. capacity	Q	3000 kg
1.6	Load center of gravity	c	500 mm
1.8	Load distance, centre of drive axle to fork	x	626 mm
1.9	Wheelbase	y	1900 mm
Weight			
2.1	Service weight		4355 kg
2.2	Weight on front axle (laden) / rear axle (laden)		6435 kg / 920 kg
2.3	Weight on front axle (Unladen) / rear axle (Unladen)		1660 kg / 2695 kg
Wheels			
3.1	Tires type		Inflatable
3.2	Dimensions of front wheels		300-15/18 6T P43
3.3	Dimensions of rear wheels		7.00-12/12 ED PLUS
3.5	Number of front wheels / rear wheels		2 / 2
3.5.2	Number of drive wheels		2
3.6	Front wheel gauge	b10	1044 mm
3.7	Rear wheel gauge	b11	1108 mm
Dimensions			
4.7	Height of overhead guard (cabin)	h6	2095 mm
4.8	Seat height/stand height	h7	972 mm
4.19	Overall length	l1	4234 mm
4.20	Length to face of forks	l2	3084 mm
4.21	Overall width	b1	1330 mm
4.22	Forks section / width / length	s / e / l	45 mm x 122 mm x 1150 mm
4.23	Fork carriage ISO 2328 (class/form) A/B		3A
4.24	Fork carriage width	b3	1260 mm
4.31	Ground clearance below mast	m1	260 mm
4.32	Ground clearance at centre of wheelbase	m2	238 mm
4.33	Aisle Width for pallets 1000 x 1200 crossways	Ast	4626 mm
4.35	Turning radius	Wa	2650 mm
Performances			
5.1	Travel speed (laden / unladen)		18 km/h-22 km/h
5.2	Lifting speed (laden / unladen)		0.50 m/s-0.50 m/s
5.3	Lowering speed (laden / unladen)		0.50 m/s-0.30 m/s
5.5	Drawbar pull (Laden / Unladen)		2140 daN / 1340 daN
5.7	Gradeability (laden / unladen)		30 % / 32 %
5.10	Service brake		Hydraulic brakes by loss of pressure
Engine			
7.1	Engine brand / model		Kubota / V2403
7.2	I.C. Engine power rating		36 kW
7.3	Rated speed		2700 rpm
7.4	Number of cylinders / Capacity of cylinders		4 - 2434 cm³
Miscellaneous			
8.1	Type of drive control		Cable
8.2	Working hydraulic pressure for attachments		180 bar
8.3	Oil flow rate for attachments		45 l/min
8.4	Measured/guaranteed mean noise level at the ear of the operator		< 80 dB
8.4	Sound level at the driver's ear according to DIN 12 053		80 dB

MSI-X 30 - Diagrama dimensional

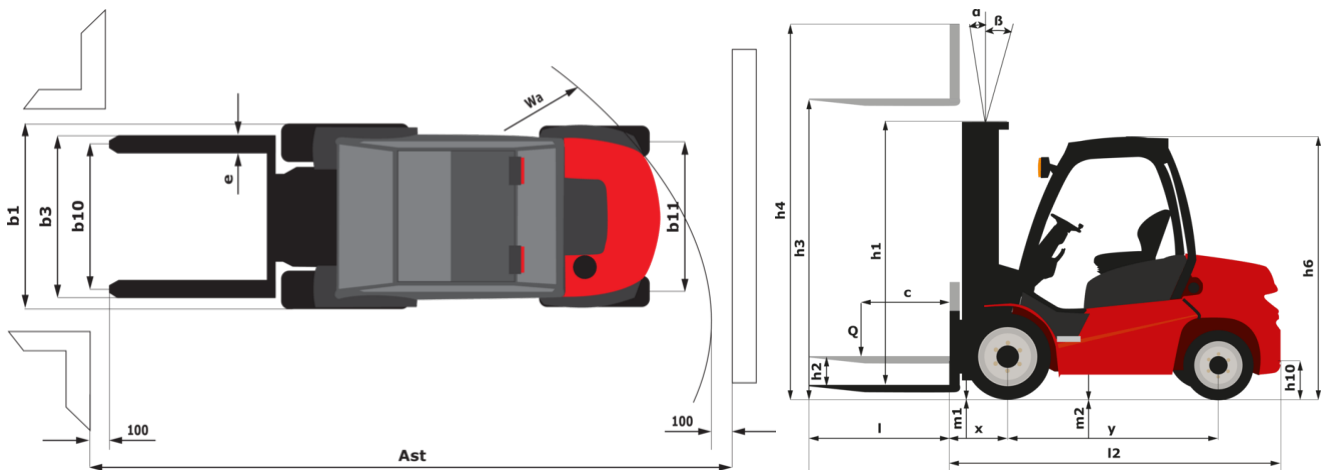

Características de los mástiles y capacidad residual

Full Visibility Duplex (FVD)		FVD 30	FVD 33	FVD 37	FVD 40	FVD 45
α - Mast/fork carriage tilt, forward	°	10	10	10	10	10
β - Mast/fork carriage tilt, backward	°	12	12	12	12	12
h1 - Mast lowered height	mm	2136	2286	2546	2736	2986
h2 - Mast free lift	mm	90	90	90	90	90
h3 - Mast lifting height	mm	3000	3300	3700	4000	4500
h4 - Mast extended height	mm	3738	4038	4438	4738	5238
Residual capacity at max height	kg	3000	3000			
Height at max capacity	mm	3000	3300	2500	2500	2500

Free Lift Triplex (FLT)		FLT 34	FLT 37	FLT 40	FLT 43	FLT 47	FLT 55	FLT 60
α - Mast/fork carriage tilt, forward	°	10	10	10	10	10	6	6
β - Mast/fork carriage tilt, backward	°	12	12	12	12	12	6	6
h1 - Mast lowered height	mm	1936	2036	2136	2286	2386	2736	2986
h2 - Mast free lift	mm	1208	1308	1408	1558	1658	2008	2258
h3 - Mast lifting height	mm	3400	3700	4000	4300	4700	5500	6000
h4 - Mast extended height	mm	4184	4484	4784	5084	5484	6284	6784
Residual capacity at max height	kg	3000						
Height at max capacity	mm	3400	2500	2500	2500	2500	2500	2500

Full Visibility Triplex (FVT)		FVT 33
h1 - Mast lowered height	mm	1826
h2 - Mast free lift	mm	77
h3 - Mast lifting height	mm	3300
h4 - Mast extended height	mm	4027
Height at max capacity	mm	2500



Oficina Central

B.P. 249 - 430 rue de l'Aubinière

44150 Ancenis Cedex - Francia

Tel.: 00 33 (0)2 40 09 10 11 - Fax: 00 33 (0)2 40 09 10 97

www.manitou.com



Esta publicación describe las versiones y posibilidades de configuración de los productos Manitou que puedan diferir en equipamiento. Los equipamientos presentados en este folleto pueden ser de serie, opcionales o no estar disponibles en algunas versiones. Manitou se reserva el derecho, en cualquier momento y sin previo aviso, de modificar las especificaciones descritas y representadas. Las especificaciones aportadas no comprometen al fabricante. Para más información, póngase en contacto con su concesionario Manitou. Documento no contractual. Presentación de los productos no contractual. Lista de especificaciones no exhaustiva. Los logos y la identidad visual de la empresa son propiedad de Manitou y no pueden ser utilizados sin autorización. Todos los derechos reservados. Las fotos y los esquemas contenidos en este folleto se ofrecen para consulta y a título indicativo solamente.

Manitou BF SA - Sociedad anónima con Consejo de Administración - Capital social: 39 668 399 euros - 857 802 508 RCS Nantes