

Technical sheet :

# **MSI 40 ST5**

---



 **MANITOU**  
HANDLING YOUR WORLD

Technical characteristics		Imperial	
1.1	Manufacturer		MANITOU
1.2	Model Name		MSI 40 ST5
1.3	Power source		Diesel
1.4	Operator type		Seated
1.5	Max. capacity	Q	8818 lb
1.6	Load center of gravity	c	20 in
1.8	Load distance, centre of drive axle to fork	x	27 in
1.9	Wheelbase	y	82 in
	Standard mast reference of the machine		FVD 37
Weight			
2.1	Service weight		15388 lb
2.2	Weight on front axle (laden)		20382 lb
2.3	Weight on front axle (Unladen)		7077 lb
Wheels			
3.1	Tires type		Pneumatic
3.2	Dimensions of front wheels		315/70 R22,5 KMAX
3.3	Dimensions of rear wheels		225/75 R15 XZM
3.5	Number of front wheels / rear wheels		2 / 2
3.5.2	Number of drive wheels		2
3.6	Front wheel gauge	b10	56 in
3.7	Rear wheel gauge	b11	45 in
Dimensions			
4.7	Height of overhead guard (cabin)	h6	96 in
4.8	Seat height/stand height	h7	56 in
4.12	Height of towing bar (coupling height)	h10	24 in
4.19	Overall length	l1	177 in
4.20	Length to face of forks	l2	130 in
4.21	Overall width	b1	68 in
4.22	Forks section / width / length	s / e / l	2 in x 6 in x 47 in
4.23	Fork carriage ISO 2328 (class/form) A/B		3A
4.24	Fork carriage width	b3	66 in
4.31	Ground clearance below mast	m1	7 in
4.32	Ground clearance at centre of wheelbase	m2	9 in
4.33	Aisle Width for pallets 1000 x 1200 crossways	Ast	195 in
4.35	Turning radius	Wa	113 in
Performances			
5.1	Travel speed (laden / unladen)		12 mph-12 mph
5.2	Lifting speed (laden)		2 ft/s
5.3	Lowering speed (laden)		2 ft/s
5.5	Drawbar pull (Laden)		3103 daN
5.7	Gradeability (laden)		34 %
5.10	Service brake		Hydraulic
Engine			
7.1	Engine brand / model		Deutz / TCD 2,9L
7.2	I.C. Engine power rating		55 kW
7.3	Rated speed		2200 rpm
7.4	Number of cylinders / Capacity of cylinders		4 - 177 in³
Miscellaneous			
8.1	Type of drive control		Electronic
8.2	Working hydraulic pressure for attachments		3336 PSI
8.3	Oil flow rate for attachments		12 US gpm
8.4	Sound level at the driver's ear according to DIN 12 053		81 dB

MSI 40 ST5 - Dimensional drawing

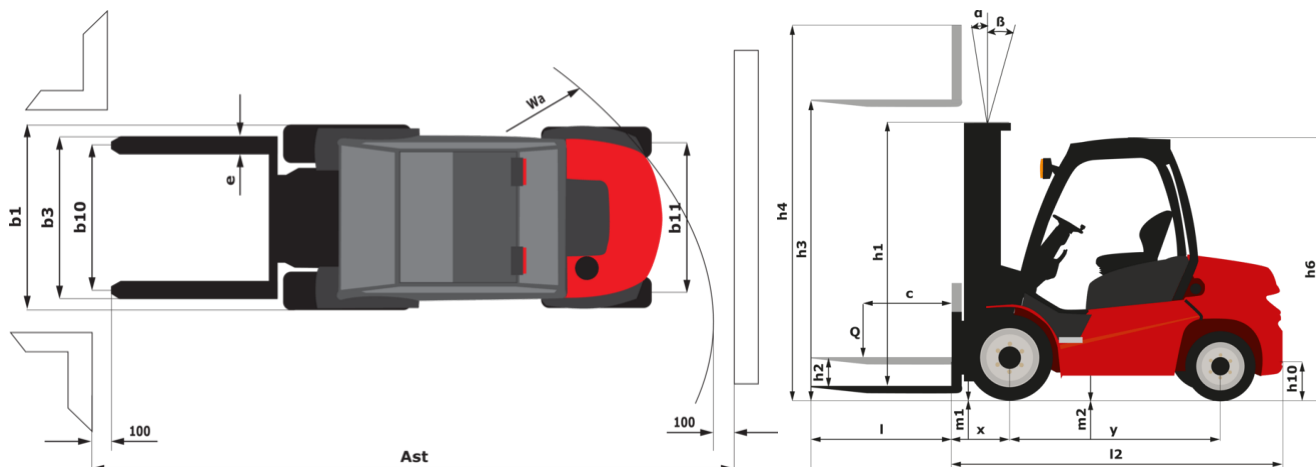

## Characteristics of masts and residual capacities

Full Visibility Duplex (FVD)		FVD 30	FVD 33	FVD 35	FVD 37	FVD 40	FVD 45	FVD 50
α - Mast/fork carriage tilt, forward	°	10	10	10	10	10	10	10
β - Mast/fork carriage tilt, backward	°	12	12	12	12	12	12	12
h1 - Mast lowered height	in	95.5	101.4	105.3	109.3	115.2	125	134.8
h3 - Mast lifting height	in	118.1	129.9	137.8	145.7	157.5	177.2	196.9
h4 - Mast extended height	in	156.6	168.4	176.3	184.1	195.9	215.6	235.3
Residual capacity at max height	lb	8818	8818	8818	8818	8818	8818	8818
Residual capacity with hooked-on side shift at max height	lb	8818	8818	8818	8818	8818	8818	8818
Height at max capacity	in	118.1	129.9	137.8	145.7	157.5	177.2	196.9
Height at max capacity with hooked-on sideshift	in	118.1	129.9	137.8	145.7	157.5	177.2	196.9

Free Lift Triplex (FLT)		FLT 37	FLT 40	FLT 43	FLT 45	FLT 47	FLT 50	FLT 55	FLT 60
α - Mast/fork carriage tilt, forward	°	10	10	10	10	10	10	10	10
β - Mast/fork carriage tilt, backward	°	12	12	12	12	12	12	12	12
h1 - Mast lowered height	in	85.6	89.6	93.5	96.5	98.8	103.3	109.3	116.1
h2 - Mast free lift	in	49.5	53.5	57.4	60.4	62.7	67.2	73.1	80
h3 - Mast lifting height	in	145.7	157.5	169.3	177.2	185	196.9	216.5	236.2
h4 - Mast extended height	in	183.7	195.6	207.4	215.2	223.1	234.9	254.6	274.3
Residual capacity at max height	lb	8818	8818	8818	8818				
Residual capacity with hooked-on side shift at max height	lb	8818	8818	8818	8818				
Height at max capacity	in	145.7	157.5	169.3	177.2	98.4	98.4	98.4	98.4
Height at max capacity with hooked-on sideshift	in	145.7	157.5	169.3	177.2				



**Head Office**

B.P. 249 - 430 rue de l'Aubinière

44150 Ancenis Cedex - France

Tel: +33 (0)2 40 09 10 11 - Fax: +33 (0)2 40 09 10 97

[www.manitou.com](http://www.manitou.com)



This publication provides a description of the configuration versions and options for Manitou products, which may differ for equipment. The equipment presented in this brochure may be part of a series, as an option, or it may not be available, depending on the versions. Manitou reserves the right, at any time and without notice, to amend the specifications described and represented. The specifications provided do not bind the manufacturer. For more details, please contact your Manitou agent. This is not a contractually binding document. The presentation of the products is not contractually binding. List of specifications non-exhaustive. The logos as well as the visual identity of the company are owned by Manitou and cannot be used without authorisation. All rights reserved. The photos and diagrams contained in this brochure are only provided for consultation and information purposes.

MANITOU BF SA - Limited company with board of directors - Share capital: 39,668,399 euros - 857 802 508 RCS Nantes