

Technical sheet :

MTA 12042 SERIES IV



 **MANITOU**
HANDLING YOUR WORLD

Capacities		Imperial
Max. capacity		12000 lb
Max. lifting height		42 ft
Max. outreach		27 ft 11 in
Weight and dimensions		
Overall length to carriage	l11	19 ft 4 in
Overall width	b1	8 ft 4 in
Overall height	h17	7 ft 11 in
Wheelbase	y	10 ft 4 in
Ground clearance	m4	18 in
Overall cab width	b4	33 in
Tilt-up angle	a4	12 °
Tilt-down angle	a5	112 °
External turning radius	Wa3	13 ft 11 in
Unladen weight (with forks)		25201 lb
Overall weight		25201 lb
Standard tires		14 x 24
Frame leveling longitudinal +/-		10 °
Frame leveling corrector	a9	10 °
Performances		
Lifting		15 s
Lowering		10 s
Extension		14 s
Retraction		10 s
Crowd		6 s
Dump		3 s
Engine		
Engine brand		Deutz
Engine norm		Tier 4 final
Engine model		TCD 3.6 L4
Number of cylinders / Capacity of cylinders		4 - 0.23 in³
I.C. Engine power rating - Power		119.35 Hp / 89 kW
Max. torque / Engine rotation		354 ft/lbs @ 1600 rpm
Transmission		
Transmission type		Torque converter with powershift gearbox
Number of gears (forward / reverse)		4 / 3
Max. travel speed		20 mph
Parking brake		Hydraulic spring release SAHR
Service brake		Wet disc brakes
Axle Manufacturer		Dana
Hydraulics		
Hydraulic pump type		Gear pump
Hydraulic flow / Pressure		41 US gpm-3002 PSI
Tank capacities		
Engine oil		4 US gal
Hydraulic oil		45 US gal
Diesel Exhaust fluid (AdBlue® type)		5 US gal
Fuel tank		47 US gal
Miscellaneous		
Steering wheels (front / rear)		2 / 2
Drive wheels (front / rear)		2 / 2
Cab certification		ROPS/FOPS
Controls		Single Joystick FNR

MTA 12042 Series IV - Dimensional drawing

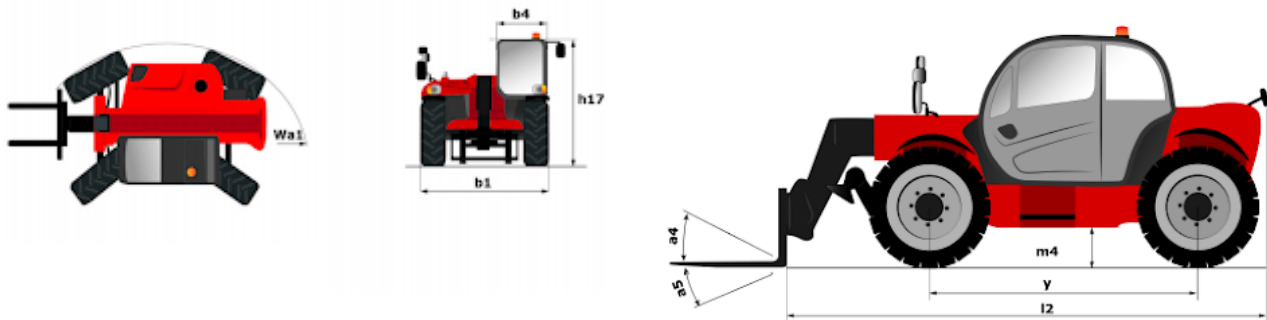

MTA 12042 Series IV - Load chart

Machine on tires with forks Imperial

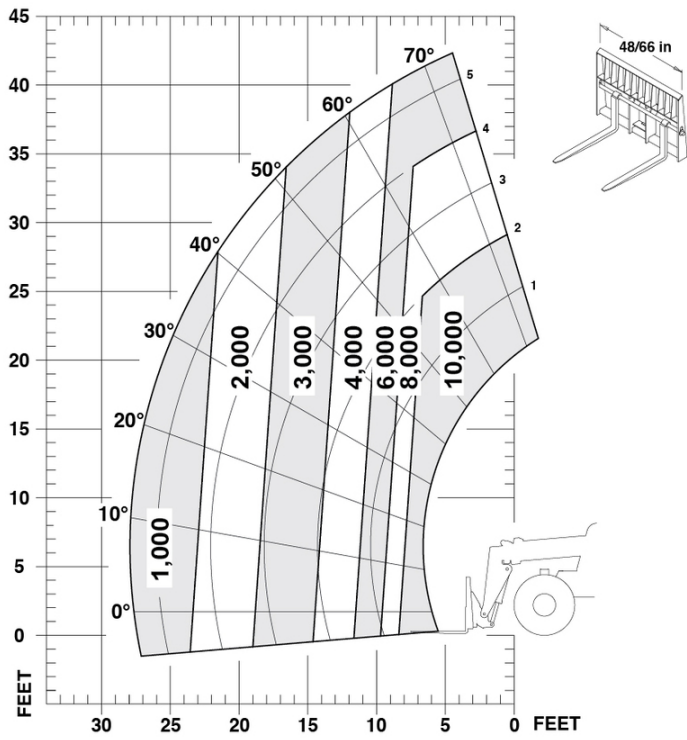



Head Office

B.P. 249 - 430 rue de l'Aubinière

44150 Ancenis Cedex - France

Tel: +33 (0)2 40 09 10 11 - Fax: +33 (0)2 40 09 10 97

www.manitou.com



This publication provides a description of the configuration versions and options for Manitou products, which may differ for equipment. The equipment presented in this brochure may be part of a series, as an option, or it may not be available, depending on the versions. Manitou reserves the right, at any time and without notice, to amend the specifications described and represented. The specifications provided do not bind the manufacturer. For more details, please contact your Manitou agent. This is not a contractually binding document. The presentation of the products is not contractually binding. List of specifications non-exhaustive. The logos as well as the visual identity of the company are owned by Manitou and cannot be used without authorisation. All rights reserved. The photos and diagrams contained in this brochure are only provided for consultation and information purposes.

MANITOU BF SA - Limited company with board of directors - Share capital: 39,668,399 euros - 857 802 508 RCS Nantes