

Technical sheet :

MTA 1255



Capacities		Metric
Max. capacity		5443.10 kg
Max. lifting height		16.95 m
Max. outreach		12.88 m
Weight and dimensions		
Length to face of forks	l2	6.40 m
Overall length (with forks)	l1	7.62 m
Overall width	b1	2.54 m
Overall height	h17	2.59 m
Wheelbase	y	3.50 m
Ground clearance	m4	0.48 m
Overall cab width	b4	0.95 m
Tilt-up angle	a4	34 °
Tilt-down angle	a5	96 °
External turning radius	Wa3	3.90 m
Overall weight		14696 kg
Tires type		Pneumatic
Forks length / width / section	l / e / s	1219 mm x 152 mm x 63.50 mm
Frame leveling corrector	a9	10 °
Performances		
Lifting		16 s
Lowering		11 s
Extension		18 s
Retraction		16 s
Crowd		4 s
Dump		6 s
Engine		
Engine brand		Deutz
Engine norm		Tier 4 final
Engine model		TCD 3.6 L4
Number of cylinders / Capacity of cylinders		4 - 3600 cm³
I.C. Engine power rating - Power		127 Hp / 95 kW
Max. torque / Engine rotation		500 Nm @ 2300 rpm
Drawbar pull		14061 daN
Transmission		
Transmission type		Powershift
Number of gears (forward / reverse)		5 / 3
Max. travel speed		32 km/h
Parking brake		Hydraulic spring release SAHR
Service brake		Wet disc brakes
Hydraulics		
Hydraulic pump type		Axial piston
Hydraulic flow / Pressure		151 l/min-275.80 bar
Tank capacities		
Engine oil		8.51 l
Hydraulic oil		159 l
Diesel Exhaust fluid (AdBlue® type)		15.14 l
Fuel tank		144 l
Noise and vibration		
Noise at driving position (LpA)		80 dB
Miscellaneous		
Steering wheels (front / rear)		2 / 2
Drive wheels (front / rear)		2 / 2
Controls		Joystick

MTA 1255 - Dimensional drawing

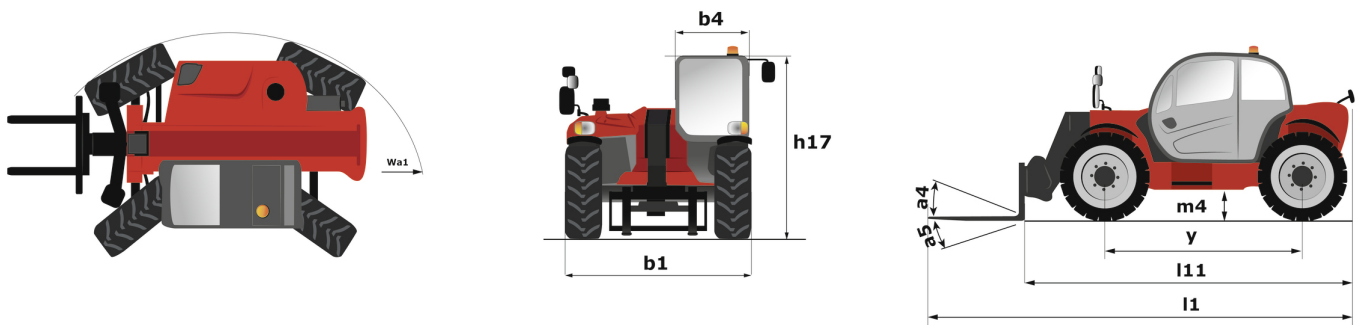

MTA 1255 - Load chart

Machine on tires with forks Metric

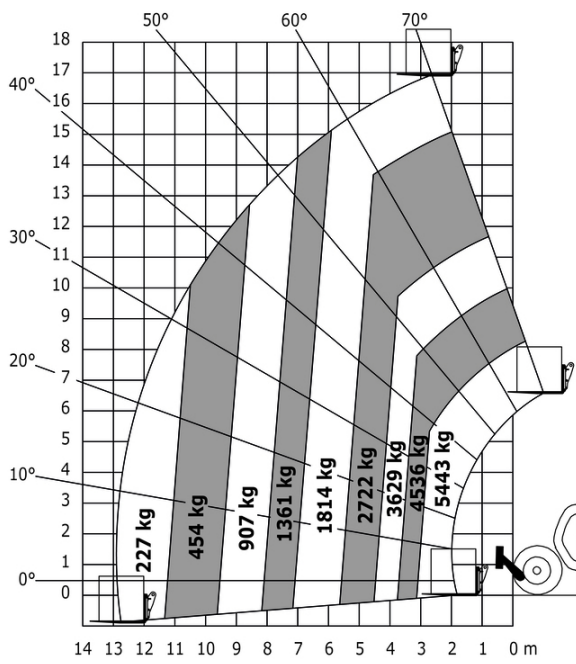

Machine on lowered stabilisers with forks Metric

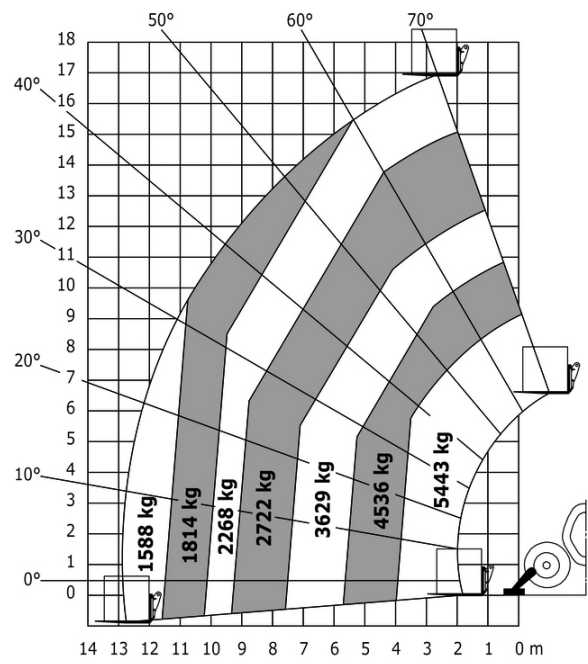



Head Office

B.P. 249 - 430 rue de l'Aubinière

44150 Ancenis Cedex - France

Tel: +33 (0)2 40 09 10 11 - Fax: +33 (0)2 40 09 10 97

www.manitou.com



This publication provides a description of the configuration versions and options for Manitou products, which may differ for equipment. The equipment presented in this brochure may be part of a series, as an option, or it may not be available, depending on the versions. Manitou reserves the right, at any time and without notice, to amend the specifications described and represented. The specifications provided do not bind the manufacturer. For more details, please contact your Manitou agent. This is not a contractually binding document. The presentation of the products is not contractually binding. List of specifications non-exhaustive. The logos as well as the visual identity of the company are owned by Manitou and cannot be used without authorisation. All rights reserved. The photos and diagrams contained in this brochure are only provided for consultation and information purposes.

MANITOU BF SA - Limited company with board of directors - Share capital: 39,668,399 euros - 857 802 508 RCS Nantes