

Technical sheet :

MTA 842 E74



| Capacities | | Imperial |
|---|-----------|-------------------------------|
| Max. capacity | | 8000 lb |
| Max. lifting height | | 42 ft 6 in |
| Max. outreach | | 28 ft 6 in |
| Weight and dimensions | | |
| Length to face of forks | l2 | 20 ft 8 in |
| Overall length (with forks) | l1 | 24 ft 8 in |
| Overall width | b1 | 8 ft 2 in |
| Overall height | h17 | 8 ft |
| Wheelbase | y | 11 ft 6 in |
| Ground clearance | m4 | 1 ft 6 in |
| Overall cab width | b4 | 3 ft 1 in |
| Tilt-up angle | a4 | 34 ° |
| Tilt-down angle | a5 | 96 ° |
| External turning radius | Wa3 | 13 ft 1 in |
| Unladen weight | | 23951 lb |
| Tires type | | Pneumatic |
| Forks length / width / section | l / e / s | 48 in x 4 in x 2 in |
| Frame leveling corrector | a9 | 10 ° |
| Performances | | |
| Lifting | | 11 s |
| Lowering | | 6 s |
| Extension | | 17 s |
| Retraction | | 11 s |
| Crowd | | 4 s |
| Dump | | 6 s |
| Engine | | |
| Engine brand | | Deutz |
| Engine norm | | Tier 4 final |
| Engine model | | TCD 3.6 L4 |
| Number of cylinders / Capacity of cylinders | | 4 - 220 in³ |
| I.C. Engine power rating - Power | | 74 Hp / 55 kW |
| Max. torque / Engine rotation | | 288 ft/lbs @ 2300 rpm |
| Drawbar pull | | 10614 kgF |
| Transmission | | |
| Transmission type | | Powershift |
| Number of gears (forward / reverse) | | 5 / 3 |
| Max. travel speed | | 20 mph |
| Parking brake | | Hydraulic spring release SAHR |
| Service brake | | Wet disc brakes |
| Hydraulics | | |
| Hydraulic pump type | | Axial piston |
| Hydraulic flow / Pressure | | 40 US gpm-4000 PSI |
| Tank capacities | | |
| Engine oil | | 2 US gal |
| Hydraulic oil | | 36 US gal |
| Fuel tank | | 38 US gal |
| Noise and vibration | | |
| Noise at driving position (LpA) | | 80 dB |
| Miscellaneous | | |
| Steering wheels (front / rear) | | 2 / 2 |
| Drive wheels (front / rear) | | 2 / 2 |

MTA 842 E74 - Dimensional drawing

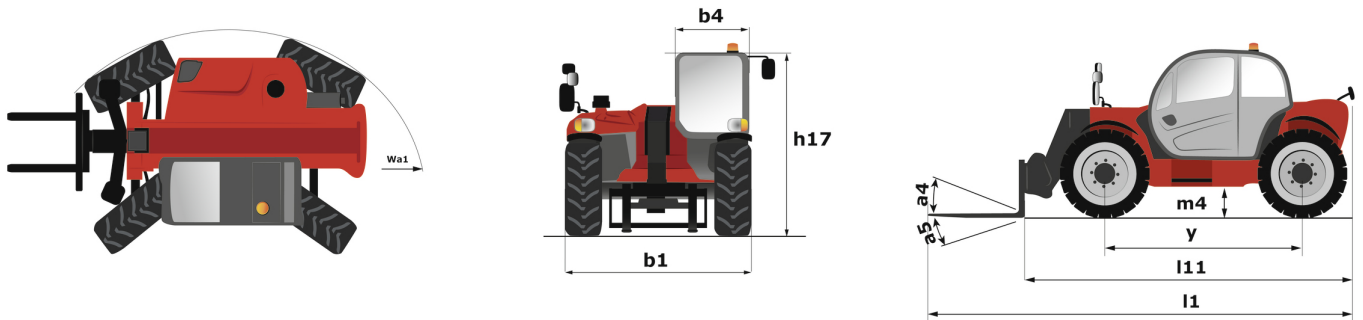

MTA 842 E74 - Load chart

Machine on tires with forks Imperial

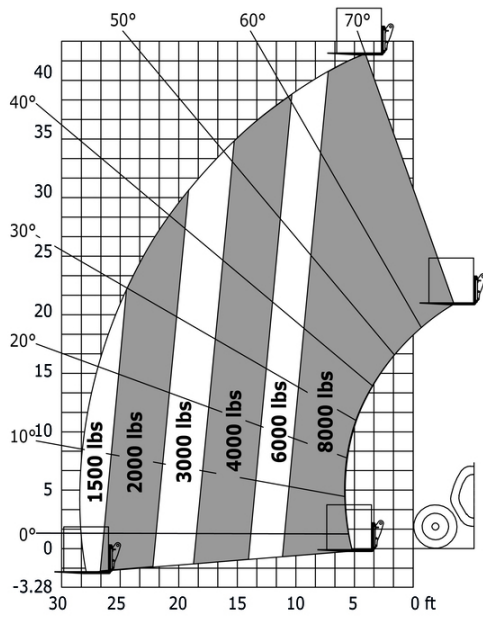



Head Office

B.P. 249 - 430 rue de l'Aubinière

44150 Ancenis Cedex - France

Tel: +33 (0)2 40 09 10 11 - Fax: +33 (0)2 40 09 10 97

www.manitou.com



This publication provides a description of the configuration versions and options for Manitou products, which may differ for equipment. The equipment presented in this brochure may be part of a series, as an option, or it may not be available, depending on the versions. Manitou reserves the right, at any time and without notice, to amend the specifications described and represented. The specifications provided do not bind the manufacturer. For more details, please contact your Manitou agent. This is not a contractually binding document. The presentation of the products is not contractually binding. List of specifications non-exhaustive. The logos as well as the visual identity of the company are owned by Manitou and cannot be used without authorisation. All rights reserved. The photos and diagrams contained in this brochure are only provided for consultation and information purposes.

MANITOU BF SA - Limited company with board of directors - Share capital: 39,668,399 euros - 857 802 508 RCS Nantes