

Ficha técnica :

2100V



 **MANITOU**
HANDLING YOUR WORLD

Capacities		Métrico
Operating Capacity At 50% Tipping Load		952.54 kg
Operating Weight		3393 kg
Unladen weight		3045 kg
Tipping capacity		1905 kg
Weight and dimensions		
Wheelbase	y	1092 mm
Overall Operating Height - Fully Raised	h27	4013 mm
Height to Hinge Pin - Fully Raised	h28	3061 mm
Overall Height to top of ROPS	h17	2032 mm
Dump angle at full height	a5	42 °
Dump height	h29	2286 mm
Overall length with bucket	l16	3543 mm
Dump reach - Full height	r6	851 mm
Rollback Angle at Full Height	a4	92 °
Seat to ground height	h30	952.50 mm
Overall width less bucket	b1	1704 mm
Ground clearance	m4	191 mm
Overall length - Less Bucket	l2	2743 mm
Clearance Radius - Front with Bucket	b18	2146 mm
Rear departure angle		25 °
Performances		
Travel speed (unladen)		12.10 km/h
Travel Speed with Two-Speed Option - Maximum		18.70 km/h
Wheels		
Transmission type		Hydrostatic
Engine		
Engine brand		Yanmar
Engine model		4TNV98C-NGL
Engine norm		Stage V, Tier 4
Gross Power		51.70 kW
Net Power		51 kW
Max. torque / Engine rotation		241 Nm / 1625 rpm
Power source		Diesel
Number of cylinders		4
I.C. Engine power rating		69.30 Hp
Engine cooling system		Water
Battery voltage		12 V
Alternator - Ampere		100 A
Starter		3 kW
Hydraulics		
Standard flow - Auxiliary hydraulics		86.50 l/min
Auxiliary Hydraulic Pressure		239 bar
High-Flow Auxiliary Hydraulics - Option		114 l/min
High-Flow Auxiliary Hydraulics Pressure - Option		200 bar
Tank capacities		
Fuel tank		106 l
Hydraulic tank capacity		22.70 l
Displacement		3.30 l

2100V - Diagrama dimensional

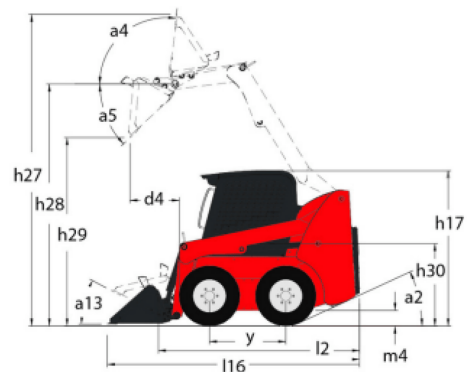
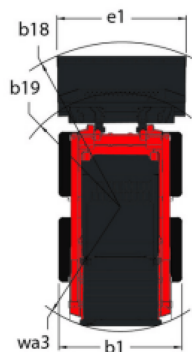



Oficina Central

B.P. 249 - 430 rue de l'Aubinière

44150 Ancenis Cedex - Francia

Tel.: 00 33 (0)2 40 09 10 11 - Fax: 00 33 (0)2 40 09 10 97

www.manitou.com



Esta publicación describe las versiones y posibilidades de configuración de los productos Manitou que puedan diferir en equipamiento. Los equipamientos presentados en este folleto pueden ser de serie, opcionales o no estar disponibles en algunas versiones. Manitou se reserva el derecho, en cualquier momento y sin previo aviso, de modificar las especificaciones descritas y representadas. Las especificaciones aportadas no comprometen al fabricante. Para más información, póngase en contacto con su concesionario Manitou. Documento no contractual. Presentación de los productos no contractual. Lista de especificaciones no exhaustiva. Los logos y la identidad visual de la empresa son propiedad de Manitou y no pueden ser utilizados sin autorización. Todos los derechos reservados. Las fotos y los esquemas contenidos en este folleto se ofrecen para consulta y a título indicativo solamente.

Manitou BF SA - Sociedad anónima con Consejo de Administración - Capital social: 39 668 399 euros - 857 802 508 RCS Nantes