

Technical sheet :

2100VT



 **MANITOU**
HANDLING YOUR WORLD

Capacities		Imperial
Rated Operating Capacity		2100 lb
Operating Capacity At 50% Tipping Load		3000 lb
Rated Operating Capacity with Optional Counterweight		2200 lb
Operating Weight		8865 lb
Unladen weight		8049 lb
Tipping capacity		5999 lb
Weight and dimensions		
Overall Operating Height - Fully Raised	h27	159 in
Height to Hinge Pin - Fully Raised	h28	121 in
Overall Height to top of ROPS	h17	81 in
Dump angle at full height	a5	42 °
Dump height	h29	91 in
Overall length with bucket	l16	139 in
Dump reach - Full height	r6	36 in
Rollback Angle at Full Height	a4	92 °
Seat to ground height	h30	38 in
Overall width less bucket	b1	66 in
Ground clearance	m4	8 in
Overall length - Less Bucket	l2	108 in
Clearance Radius - Front with Bucket	b18	87 in
Rear departure angle		25 °
Performances		
Travel speed (unladen)		6 mph
Travel Speed with Two-Speed Option - Maximum		10 mph
Wheels		
Transmission type		Hydrostatic
Engine		
Engine brand		Yanmar
Engine model		4TNV98C-NGL
Engine norm		Tier 4
Gross Power		69.30 Hp
Max. torque / Engine rotation		178 ft/lbs / 1625 rpm
Power source		Diesel
Number of cylinders		4
Engine cooling system		Water
Battery voltage		12 V
Alternator - Ampere		100 A
Starter		3 kW
Hydraulics		
Standard flow - Auxiliary hydraulics		23 US gpm
Auxiliary Hydraulic Pressure		3475 PSI
High-Flow Auxiliary Hydraulics - Option		30 US gpm
High-Flow Auxiliary Hydraulics Pressure - Option		3325 PSI
Tank capacities		
Fuel tank		38 US gal
Hydraulic tank capacity		6 US gal
Displacement		0.87 US gal

2100VT - Dimensional drawing

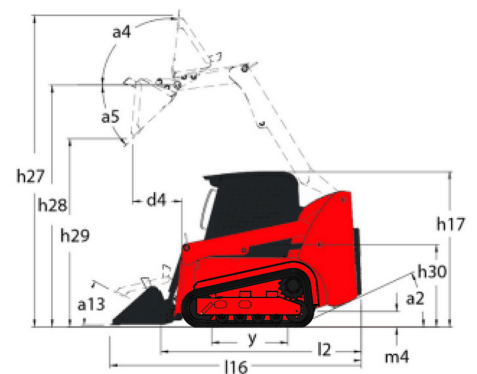
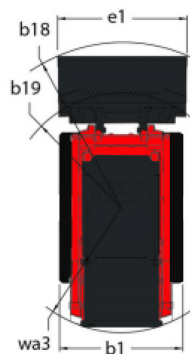



 **MANITOU**
HANDLING YOUR WORLD

Head Office

B.P. 249 - 430 rue de l'Aubinière

44150 Ancenis Cedex - France

Tel: +33 (0)2 40 09 10 11 - Fax: +33 (0)2 40 09 10 97

www.manitou.com



This publication provides a description of the configuration versions and options for Manitou products, which may differ for equipment. The equipment presented in this brochure may be part of a series, as an option, or it may not be available, depending on the versions. Manitou reserves the right, at any time and without notice, to amend the specifications described and represented. The specifications provided do not bind the manufacturer. For more details, please contact your Manitou agent. This is not a contractually binding document. The presentation of the products is not contractually binding. List of specifications non-exhaustive. The logos as well as the visual identity of the company are owned by Manitou and cannot be used without authorisation. All rights reserved. The photos and diagrams contained in this brochure are only provided for consultation and information purposes.

MANITOU BF SA - Limited company with board of directors - Share capital: 39,668,399 euros - 857 802 508 RCS Nantes