

Technical sheet :

3300V NXT2



 **MANITOU**
HANDLING YOUR WORLD

Capacities		Imperial
Rated Operating Capacity		3300 lb
Unladen weight		9090 lb
Weight and dimensions		
Wheelbase	y	49 in
Overall Operating Height - Fully Raised	h27	172 in
Height to Hinge Pin - Fully Raised	h28	131 in
Overall Height to top of ROPS	h17	82 in
Dump angle at full height	a5	42 °
Dump height	h29	99 in
Overall length with bucket	l16	153 in
Dump reach - Full height	r6	32 in
Rollback at ground	a13	29 °
Seat to ground height	h30	41 in
Overall width less bucket	b1	72 in
Bucket Width	e1	74 in
Ground clearance	m4	9 in
Overall length - Less Bucket	l2	119 in
Departure angle	a2	25 °
Clearance Radius - Front with Bucket	b18	94 in
Performances		
Travel speed (unladen)		8 mph
Travel Speed with Two-Speed Option - Maximum		12 mph
Wheels		
Standard tires		14.00 x 17.5 HD
Engine		
Engine brand		Yanmar
Engine model		4TNV98CT-NMS
Engine norm		Tier 4
Gross Power		72 Hp
Max. torque / Engine rotation		217 ft/lbs / 2500 rpm
Power source		Diesel
Battery voltage		12 V
Alternator		95 kW
Starter		3 kW
Hydraulics		
Standard flow - Auxiliary hydraulics		24 US gpm
Auxiliary Hydraulic Pressure		3450 PSI
High-Flow Auxiliary Hydraulics - Option		35 US gpm
High-Flow Auxiliary Hydraulics Pressure - Option		3200 PSI
Tank capacities		
Fuel tank		24 US gal
Hydraulic tank capacity		11 US gal
Displacement		0.87 US gal
Noise and vibration		
Noise to environment (LWA)		101 dB
Noise at driving position (LpA)		85 dB
Whole-Body Vibration (ISO 2631-1)		0.79 m/s ²
Vibration on hands/arms		< 1.20 m/s ²

3300V NXT2 - Dimensional drawing

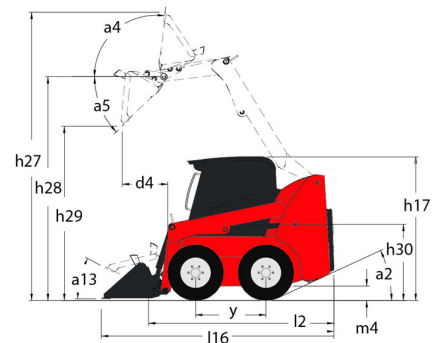

Equipment

—	
Integral Access Plate (removable)	Standard
Lifting function	
All-Tach® Attachment Mounting System	Standard
Auxiliary Hydraulics	Standard
High-Flow Auxiliary Hydraulics	Optional
Power-A-Tach® Attachment Mounting System	Optional
Lighting	
Work Lights - Front and Rear	Standard
Motorization/Power	
Engine Auto-Shutdown System	Standard
Engine Block Heater	Optional
Turbo-Charged Engine	Standard
Two-Speed Drive	Standard
Operator station	
Adjustable Arm Rests / Control Towers 1	Standard
Air conditioning with manual adjustment	Optional
Air suspension seat	Optional
Cab Enclosure	Optional
Dual-Hand Controls	Optional
Foot and Hand Throttles 2	Standard
Gehl T-Bar Controls	Optional
Hand/Foot Controls	Optional
Heating	Optional
High-Back Adjustable Seat	Standard
Horn	Standard
Joystick controls	Optional
ROPS/FOPS Level II Overhead Guard	Standard
Sound Reduction Material	Standard
Suspension Seat - Mechanical	Optional
Other options	
Hydrostatic Drive - Servo	Standard
Selectable Self-Leveling Hydraulic Lift Action 4	Optional
Secondary functions	
Counterweight	Standard
Full Instrumentation	Standard
Hydraglide™ Ride Control 3	Standard
Security	
Anti-Vandalism Protection	Standard
Back-Up Alarm	Optional
Brake Control (Auto / Manual)	Standard
Hydraloc™ Safety System	Standard
Lift Arm Support Device	Standard
Operator Restraint Bar	Standard



Head Office

B.P. 249 - 430 rue de l'Aubinière

44150 Ancenis Cedex - France

Tel: +33 (0)2 40 09 10 11 - Fax: +33 (0)2 40 09 10 97

www.manitou.com



This publication provides a description of the configuration versions and options for Manitou products, which may differ for equipment. The equipment presented in this brochure may be part of a series, as an option, or it may not be available, depending on the versions. Manitou reserves the right, at any time and without notice, to amend the specifications described and represented. The specifications provided do not bind the manufacturer. For more details, please contact your Manitou agent. This is not a contractually binding document. The presentation of the products is not contractually binding. List of specifications non-exhaustive. The logos as well as the visual identity of the company are owned by Manitou and cannot be used without authorisation. All rights reserved. The photos and diagrams contained in this brochure are only provided for consultation and information purposes.

MANITOU BF SA - Limited company with board of directors - Share capital: 39,668,399 euros - 857 802 508 RCS Nantes