

Technical sheet :

1050RT



 **MANITOU**
HANDLING YOUR WORLD

Capacities		Metric
Operating Weight		2141 kg
Unladen weight		1928 kg
Operating Capacity at 35% Tipping Load		476 kg
Operating Capacity At 50% Tipping Load		680 kg
Tipping capacity		1361 kg
Weight and dimensions		
Overall Operating Height - Fully Raised	h27	3650 mm
Height to Hinge Pin - Fully Raised	h28	2769 mm
Dump reach - Full height	r6	673.10 mm
Dump angle at full height	a5	38 °
Dump Height - Fully Raised	h29	2134 mm
Maximum Rollback Angle - Fully Raised	a4	102 °
Overall Height to top of ROPS	h17	1816 mm
Overall length with bucket	l16	2985 mm
Overall Length without Bucket	l1	2258 mm
Specified Height	h31	1466 mm
Reach at Specified Height	r4	991 mm
Dump angle at specified height	a17	72 °
Carry Position	d5	127 mm
Maximum Rollback Angle at Carry Position	a14	32 °
Digging Position	h32	0 mm
Angle of Departure with STD Counterweight		35 °
Ground clearance	m4	191 mm
Track gauge	b10	1039 mm
Track Shoe Width	b20	250 mm
Crawler base	y2	1283 mm
Overall width less bucket	b1	1290 mm
Bucket Width	e1	1372 mm
Clearance Radius - Front with Bucket	b18	1854 mm
Angle of Approach	a3	90 °
Grouser Height		25 mm
Track Type / Track Rollers / Roller Type		Rubber / 4 / Steel
Performances		
Ground Speed - Single Speed		10.10 km/h
Drawbar Pull/Tractive Effort		1996 kg
Bucket Breakout - Tilt Cylinder		1346 kg
Bucket Breakout - Lift Cylinder		1376 kg
Engine		
Engine brand		Yanmar
Engine model		3TNV88C-KMSV
Motor Type		Radial Piston
Engine power (Hp)		34.20 Hp
Engine power (kW)		23.70 kW
Max. torque		109.40 Nm
Battery voltage		12 V
Cold Cranking Amps at Temperature (CCA)		800 A
Alternator - Voltage / Ampere		12 V / 55 A
Hydraulics		
Standard flow - Auxiliary hydraulics		55 l/min
Tank capacities		
Oil Pan Capacity		5.87 l
Hydraulic tank capacity		30 l
Fuel		36 l
Cooling liquid		6.62 l
Displacement / Number of cylinders		1.64 l / 3
Noise and vibration		
Noise to environment (LwA)		101 dB
Noise at driving position (LpA)		85.80 dB
Miscellaneous		
Ground Pressure		0.33 bar

1050RT - Dimensional drawing

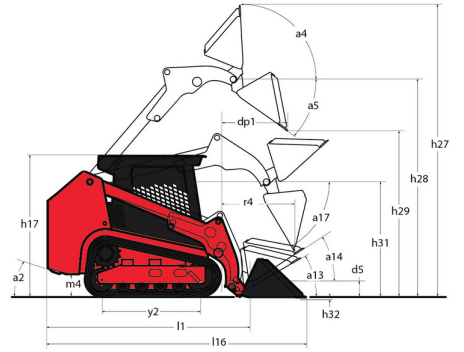
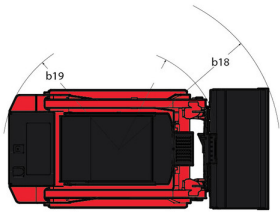

Equipment

Lifting function	
All-Tach® Attachment Mounting System	Standard
Auxiliary Hydraulics	Standard
IdealTrax® automatic track tensioning system	Standard
Motorization/Power	
Combination Radiator & Hydraulic Oil Cooler	Standard
Dual-Element Air Cleaner with Indicator	Standard
Engine Auto-Shutdown System	Optional
Glowplugs Starts Assist	Standard
Operator station	
Foot Throttle	Standard
Full-Suspension Seat	Optional
Multi-Function Display Screen	Standard
ROPS/FOPS Level II Overhead Guard	Standard
Sliding Side Windows	Standard
Swing-out Cab Door	Standard
Other options	
Selectable Self-Leveling Hydraulic Lift Action 4	Optional
Pneumatics	
Rubber Track Undercarriage System	Standard
Secondary functions	
Counterweight	Standard
Dedicated Undercarriage	Standard
Security	
Anti-Vandalism Protection	Standard
Back-Up Alarm	Standard
Easy Manager	Standard
Engine Alert System with Error Display	Standard
Mechanical Lift Cylinder Lock	Standard



Head Office

B.P. 249 - 430 rue de l'Aubinière
44150 Ancenis Cedex - France

Tel: +33 (0)2 40 09 10 11 - Fax: +33 (0)2 40 09 10 97

www.manitou.com



This publication provides a description of the configuration versions and options for Manitou products, which may differ for equipment. The equipment presented in this brochure may be part of a series, as an option, or it may not be available, depending on the versions. Manitou reserves the right, at any time and without notice, to amend the specifications described and represented. The specifications provided do not bind the manufacturer. For more details, please contact your Manitou agent. This is not a contractually binding document. The presentation of the products is not contractually binding. List of specifications non-exhaustive. The logos as well as the visual identity of the company are owned by Manitou and cannot be used without authorisation. All rights reserved. The photos and diagrams contained in this brochure are only provided for consultation and information purposes.

MANITOU BF SA - Limited company with board of directors - Share capital: 39,668,399 euros - 857 802 508 RCS Nantes