

Fiche technique :

1050RT



Capacities		Métrique
Operating Weight		2141 kg
Unladen weight		1928 kg
Operating Capacity at 35% Tipping Load		476 kg
Operating Capacity At 50% Tipping Load		680 kg
Tipping capacity		1361 kg
Weight and dimensions		
Overall Operating Height - Fully Raised	h27	3650 mm
Height to Hinge Pin - Fully Raised	h28	2769 mm
Dump reach - Full height	r6	673.10 mm
Dump angle at full height	a5	38 °
Dump Height - Fully Raised	h29	2134 mm
Maximum Rollback Angle - Fully Raised	a4	102 °
Overall Height to top of ROPS	h17	1816 mm
Overall length with bucket	l16	2985 mm
Overall Length without Bucket	l1	2258 mm
Specified Height	h31	1466 mm
Reach at Specified Height	r4	991 mm
Dump angle at specified height	a17	72 °
Carry Position	d5	127 mm
Maximum Rollback Angle at Carry Position	a14	32 °
Digging Position	h32	0 mm
Angle of Departure with STD Counterweight		35 °
Ground clearance	m4	191 mm
Track gauge	b10	1039 mm
Track Shoe Width	b20	250 mm
Crawler base	y2	1283 mm
Overall width less bucket	b1	1290 mm
Bucket Width	e1	1372 mm
Clearance Radius - Front with Bucket	b18	1854 mm
Angle of Approach	a3	90 °
Grouser Height		25 mm
Track Type / Track Rollers / Roller Type		Rubber / 4 / Steel
Performances		
Ground Speed - Single Speed		10.10 km/h
Drawbar Pull/Tractive Effort		1996 kg
Bucket Breakout - Tilt Cylinder		1346 kg
Bucket Breakout - Lift Cylinder		1376 kg
Engine		
Engine brand		Yanmar
Engine model		3TNV88C-KMSV
Motor Type		Radial Piston
Gross Power / Power		25.50 kW @ 2800 rpm
Net Power / Power		23.70 kW / 2800 rpm
Max. torque		109.40 Nm
I.C. Engine power rating		34.20 Hp
Battery voltage		12 V
Cold Cranking Amps at Temperature (CCA)		800 A
Alternator - Voltage / Ampere		12 V / 55 A
Hydraulics		
Standard flow - Auxiliary hydraulics		55 l/min
Tank capacities		
Oil Pan Capacity		5.87 l
Hydraulic tank capacity		30 l
Fuel tank		36 l
Liquid cooling tank volume		6.62 l
Displacement / Number of cylinders		1.64 l / 3
Noise and vibration		
Noise to environment (LwA)		101 dB
Noise at driving position (LpA)		85.80 dB
Miscellaneous		
Ground Pressure		0.33 bar

1050RT - Schémas d'encombrement

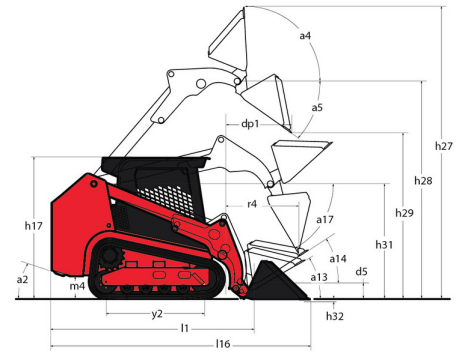
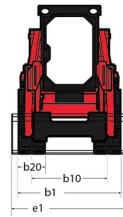

Équipements

Lifting function	
All-Tach® Attachment Mounting System	Série
Auxiliary Hydraulics	Série
IdealTrax® automatic track tensioning system	Série
Motorization/Power	
Combination Radiator & Hydraulic Oil Cooler	Série
Dual-Element Air Cleaner with Indicator	Série
Engine Auto-Shutdown System	Option
Glowplugs Starts Assist	Série
Operator station	
Foot Throttle	Série
Full-Suspension Seat	Option
Multi-Function Display Screen	Série
ROPS/FOPS Level II Overhead Guard	Série
Sliding Side Windows	Série
Swing-out Cab Door	Série
Other options	
Selectable Self-Leveling Hydraulic Lift Action 4	Option
Pneumatics	
Rubber Track Undercarriage System	Série
Secondary functions	
Counterweight	Série
Dedicated Undercarriage	Série
Security	
Anti-Vandalism Protection	Série
Back-Up Alarm	Série
Easy Manager	Série
Engine Alert System with Error Display	Série
Mechanical Lift Cylinder Lock	Série



Siège Social

B.P. 249 - 430 rue de l'Aubinière

44150 Ancenis Cedex - France

Tel: +33 (0)2 40 09 10 11 - Fax: +33 (0)2 40 09 10 97

www.manitou.com



Cette publication présente le descriptif des versions et possibilités de configuration des produits Manitou qui peuvent différer en équipement. Les équipements présentés dans cette brochure peuvent être de série, en option, ou non disponibles suivant les versions. Manitou se réserve le droit, à tout moment et sans préavis, de modifier les spécifications décrites et représentées. Les spécifications portées n'engagent pas le constructeur. Pour plus de détails, contactez votre concessionnaire Manitou. Document non contractuel. Présentation des produits non contractuelle. Liste des spécifications non exhaustive. Les logos ainsi que l'identité visuelle de l'entreprise sont la propriété de Manitou et ne peuvent être utilisés sans autorisation. Tous droits réservés. Les photos et schémas contenus dans la présente brochure ne sont fournis qu'à des fins de consultation et à titre indicatif.

Manitou BF SA - Société anonyme à conseil d'administration - Capital social : 39 668 399 euros - 857 802 508 RCS Nantes