

# RS 4-14 GEN:3

RS



**GEHL**®

Capacities		Imperial
Max. capacity		4400 lb
Max. lifting height		14 ft 3 in
Max. outreach		9 ft
Breakout force with bucket		1886 daN
Weight and dimensions		
Overall length to carriage	l11	11 ft 11 in
Length to face of forks	l2	11 ft 9 in
Overall width	b1	4 ft 11 in
Overall height	h17	6 ft 3 in
Wheelbase	y	7 ft
Ground clearance	m4	9 in
Overall cab width	b4	2 ft 7 in
Tilt-up angle	a4	12 °
Tilt-down angle	a5	116 °
External turning radius (over tyres)	Wa1	10 ft 1 in
Unladen weight (with forks)		9237 lb
Overall weight		9237 lb
Tires type		Pneumatic
Engine		
Engine brand		Kubota
Engine norm		Stage V
Engine model		2607-CR-E5
Number of cylinders / Capacity of cylinders		4 - 160 in <sup>3</sup>
I.C. Engine power rating - Power		56.30 Hp / 42 kW
Max. torque / Engine rotation		128 ft/lbs @ 2700 rpm
Drawbar pull		2850 daN
Drawbar pull (Laden)		2850 daN
Transmission		
Transmission type		Hydrostatic
Number of gears (forward / reverse)		2 / 2
Max. travel speed		16 mph
Parking brake		Automatic Negative Hand-brake
Service brake		Disk brake on the cadran shaft
Axle Manufacturer		Dana
Hydraulics		
Hydraulic pump type		Gear pump
Hydraulic flow / Pressure		20 US gpm-3408 PSI
Tank capacities		
Engine oil		3 US gal
Hydraulic oil		18 US gal
Fuel tank		16 US gal
Miscellaneous		
Steering wheels (front / rear)		2 / 2
Drive wheels (front / rear)		2 / 2
Safety / Safety cab homologation		Standard EN 15000 / ROPS/FOPS
Controls		Single Joystick FNR

# RS 4-14 GEN:3 - Load chart

Machine on tires with forks Imperial

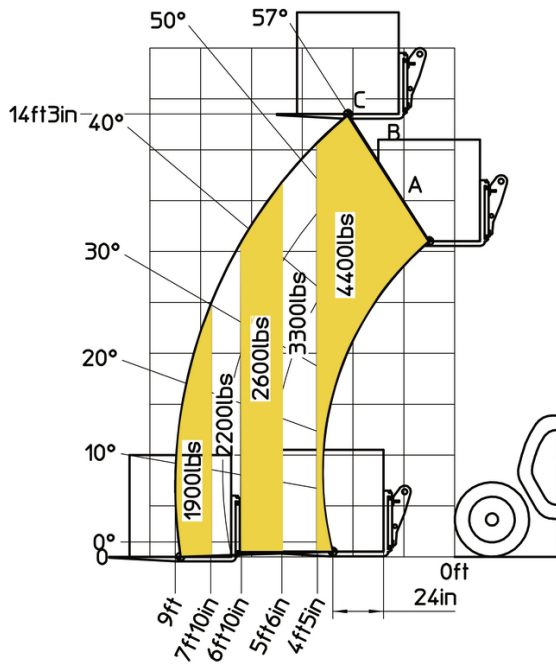



# GEHL®

Siège Social  
P.O. Box 179 - One Gehl Way - West Bend, WI, USA 53095  
Tel: (262) 334-9461 - Fax: (262) 338-7517  
[www.gehl.com](http://www.gehl.com)



This brochure describes versions and configuration options for Gehl products which may be fitted with different equipment. The equipment described in this brochure may be standard, optional or not available depending on version. Gehl reserves the right to change the specifications shown and described at any time and without prior warning. The manufacturer is not liable for the specifications given. For more information, contact your Gehl dealer. Non-contractual document. Product descriptions may differ from actual products. List of specifications is not comprehensive. The logos and visual identity of the company are the property of Gehl and may not be used without authorization. All rights reserved. The photos and diagrams contained in this brochure are provided for information only.

MANITOU EQUIPMENT AMERICAS, LLC - Limited company with board of directors - Share capital: 39,668,399 euros - 857 802 508 RCS West Bend